



Islamic University of Technology

Smart and Energy Efficient Wireless Embedded Home Automation System

A Thesis Presented to
The Academic Faculty

by

Mohammad Bazlur Rashid (102431)
Joheb Muhammad Tanzeer Sayeed (102401)
MD. Wahidur Rahman Shakil (102407)

In Partial Fulfillment
Of the Requirement for the Degree
Bachelor of Science in Electrical and Electronic Engineering
Academic Year: 2013-2014

Department of Electrical and Electronic Engineering
Islamic University of Technology (IUT)
A Subsidiary Organ of OIC
Gazipur, Bangladesh

A Dissertation on,
**Smart and Energy Efficient Wireless Embedded
Home Automation System**

Approved By

Dr. Md. Shahid Ullah
Head of the Department & Professor
Department of Electrical and Electronic Engineering
Islamic University of Technology (IUT)
Gazipur-1704, Bangladesh.

Supervised by

Dr. Khandokar Habibul Kabir
Thesis Supervisor & Associate Professor
Department of Electrical and Electronic Engineering
Islamic University of Technology (IUT)
Gazipur-1704, Bangladesh.

Declaration of Authorship

This is to certify that the work presented in this thesis is the outcome of the analysis and investigation carried out by Mohammad Bazlur Rashid, Joheb Muhammad Tanzeer Sayeed and MD. Wahidur Rahman Shakil under the supervision of Dr. Khandokar Habibul Kabir in the Department of EEE, IUT, Gazipur, Bangladesh. It is also declared that neither of the thesis nor any part of this thesis has been submitted anywhere else for any degree or diploma. Information derived from the published and unpublished work of others has been acknowledged in the text and a list of references is given.

Authors

Mohammad Bazlur Rashid
Student ID: 102431

Joheb Muhammad Tanzeer Sayeed
Student ID: 102401

MD. Wahidur Rahman Shakil
Student ID: 102407

Abstract

Automation is the technique, method or system of operating or controlling a process by highly automatic means, as by electronic devices, reducing human intervention to a minimum. An automated home appears "intelligent" because its computer systems can monitor so many aspects of daily living. We are living in the era where automation is playing important role in human life. Home automation allows us to control household appliances like light, door, window, fan etc. Home automation not only refers to reduce human efforts but also energy efficiency and time saving. The main objective of home automation is to help handicapped and old aged people which will enable them to control home appliances and alert them in critical situations.

This paper put forwards the design of home automation system using simple components like Arduino uno and conventional sensors. The design is based on a standalone embedded system at home. The home appliances are connected to the embedded system and their status is controlled by arduino. We would develop an authenticated system to control the home appliances. Scalable energy usage and less modification is much important. It presents the design and implementation of automation system.

Keywords-Home Automation; Arduino uno; Embedded Systems; Sensors; Motors.

Preface

The undergraduate thesis, “**Smart and Energy Efficient Wireless Embedded Home Automation System**” has been written for the completion of Bachelor of Science degree at Islamic University of Technology (IUT). This thesis work and writing has been done during the year 2014 under the supervision of Dr. Khandokar Habibul Kabir, Asst. Professor of the department of Electrical and Electronic Engineering, IUT.

We would like to show our gratitude towards our thesis supervisor Dr. Khandokar Habibul Kabir to give us the opportunity to work under his guidance. We would also like to thank our respected faculty members to help us to make our project experience effective and fruitful.

Contents

List of Figures	8
List of Flow Charts	9
Introduction	10
1.1 Overview	10
1.1.1 Assumption	11
1.1.2 Project selection.....	11
1.2 Motivation.....	11
1.3Major challenges.....	12
Home Automation	13
2.1 Scenario in our country.....	14
2.2 Smart home.....	14
2.2.1 Importance of Home Automation.....	15
2.3 Components for Home Automation	16
Controlled Devices	16
Sensing Devices.....	16
Controllers.....	16
I/O Interface Devices	17
System Network.....	17
Programming Computer	17
2.4 Limitations of Home Automation	18
2.4.1 Installation Costs.....	18
2.4.2 Technological limitations	18
2.4.3 Human Error.....	19
2.4.4 Reliability.....	20
2.5 Formation of Home automation system.....	20
2.5.1 Advantages of home automation	21
3.1 Objective	23
3.2 Automatic switching of fans and light	23

3.2.1 Components required	24
3.2.2 Software based Implementation	26
3.3 Curtain movement control.....	31
3.3.1 Components required	32
3.4 Counting the number of people in the room.....	36
Advantages.....	36
Components.....	36
Explanation	38
3.5 Automatic control of window	38
Components.....	38
Chapter 4.....	41
4.1 More possibilities.....	41
4.2 Home Automation System using GSM module.....	41
Advantages.....	42
Disadvantages	42
4.3 Home Automation using Remote Controller	43
4.3.1 HAS using IR remote	43
4.4 HAS using Bluetooth	43
4.5 HAS using web interface	44
4.6 Interconnected System	45
4.7 Security incorporated in System.....	46
4.3.8 Making Own Device/Product	46
Conclusion.....	47
References	48

List of Figures

- Figure 2.1 Home Automation 13
- Figure 2.2 Smart Home 15
- Figure 3.1 Arduino uno 25
- Figure 3.2 IR emitter and receiver 25
- Figure 3.3 Interruption in IR 27
- Figure 3.4 Initially the light is off 29
- Figure 3.5 When the first person enters, lights on 30
- Figure 3.6 second person enters, lights remain on 30
- Figure 3.7 when both persons left, lights are off 31
- Figure 3.8 Curtain movement control 32
- Figure 3.9 Arranrements of components 39
- Figure 3.10 wheel rotation when water falls on sensor 39
- Figure 3.11 Automatic window control 40

List of Flow Charts

Flow Chart 3.1 Working principle of IR.....	28
Flow Chart 3.2 counting the number of people.....	37

Chapter 1

Introduction

With the technological advancement, our necessity increases. As we are in a 3rd world country, the difference of demand and supply of energy is an obvious obstacle. The supply and demand of electrical energy is challenged within the context of environmental awareness and national security. As the electrical energy is an intangible necessity, it plays a critical role in our life. We have a limited amount of power supply and that actually doesn't match our gross need. Again, to cope up with the modern world and to have a comfortable life, we have to have a system that can manage the goal. Home automation is a wonderful solution to this problem which can reduce the energy wastage and can also give us an easy comfortable lifestyle. In this thesis paper we attempt to simulate some real home appliances to be automated to save energy usage in easy way using arduino and some usual sensors. As the title says, it's an energy efficient smart home system with low cost that meets our necessity.

1.1 Overview

Our home automation system consists of several types of sensors placed in particular areas to fulfill our required demand. All the sensors are connected to the arduino where all the data processing is done. The arduino gives the command to particular motor or other mechanical devices to show the result as asked. It does the work depending on the environmental change

inside or outside the room. The final result that we see is the automatic control over home appliances.

1.1.1 Assumption

We have considered a usual Bangladeshi home with some natural problems that people have to face in their day to day life. We have taken in account the possibility that people living in the house have typical home appliance problems and they need the work to be done within low cost but it must reduce their work and give some relieve in their household works.

1.1.2 Project selection

We have chosen some basic projects in home automation to fulfill our destination. Understanding how the energy is spent and knowing how to monitor and control it is the prerequisites of our work. We can reduce energy wastage and also save our time by making the home appliances automated. Then it will be in operation only when it's needed and otherwise it will be off. As most people of Bangladesh have financial problems, keeping that in mind we have selected this project that can save their money by limiting energy usage (only that much to meet their needs) and also can make their life easy and comfortable.

1.2 Motivation

Our primary motivation is based on some basic aspects as following:

- Demand of people, specially for Bangladesh.
- To keep pace with the modern world
- Geographical and climate convenience
- Making life easier
- Making user friendly systems that can be controlled easily even by a person who isn't much familiar to technology.

So, our target was to make a residential extension of building automation that can meet the basic need of the people of our country with an easy and comfortable process and try to make it connected to the available technological advancements.

1.3 Major challenges

In this project work, we had to consider several major challenges that we had to overcome. The top most prior problem was to make the system qualified for our very own Bangladeshi people who have financial problems also. Then the consideration was on fulfilling the need of comfort. Basically we faced the following challenges in way to accomplish our goal:

- making a low cost device that's available to everyone
- using very usual and common equipment
- programming the home in a simple and understandable method
- keeping in mind the basic demand of our people
- consistent power supply
- taking all the ac appliances under control

Chapter 2

Home Automation

The phrase “Home Automation” is used to encompass so much stuff that it’s not possible to elaborate it shortly. Basically it’s a system that can be controlled by low power one or more computers to have a control on overall basic functions and operations of a home. Home automation can include the scheduling and automatic operation of lighting, window coverings, heating and air conditioning and other home appliances. Home automation may also allow vital home functions to be controlled remotely from anywhere in the world using a computer connected to the Internet.

The fundamental components of a well-designed home automation system include a low power computer (or computers) with the appropriate programming, the various devices and systems to be controlled, interconnecting cables or wireless links, an emergency backup power source, its peripherals, and the essential home systems.

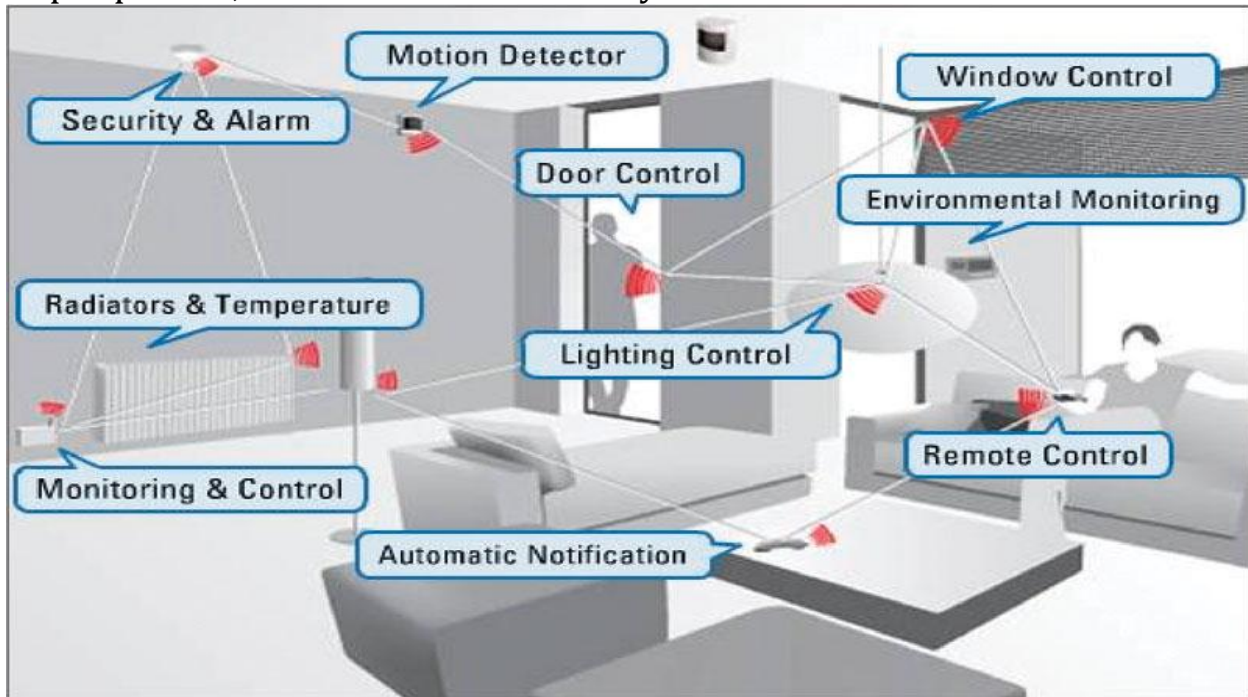

Figure 2.1 Home Automation

2.1 Scenario in our country

In a 3rd world country like Bangladesh, amount of energy is limited. Moreover, we have a huge amount of energy wastage due to lack of control over them. So, it's very important for our people to have energy efficient system that can be implemented easily. Again, most of our people don't have much money, so the system should also be cost effective.

Hence, to account for the aforementioned drawbacks of the present condition, a home automated system needs to be deployed which will allow reduction in energy wastage with a good control over them. This is obtained by using the sensors with appropriate protocol.

2.2 Smart home

An automated home is sometimes called a smart home and may be considered as future home. A *smart house* is a house that has highly advanced automatic systems for lighting, window and door operations, temperature control, and many other functions. Basically we are making the home enable to be self-organized which can take care of itself and share our responsibilities as well. Thus, a smart home will not just be a home but also our companion. An automated home appears "intelligent" because its computer systems can monitor so many aspects of daily living. It may include following aspects:

- Lighting control of our room.
- Automatic closing and opening of window.
- Window curtain control.
- Ventilation control.
- Temperature control.
- Counting people in a room and so on.

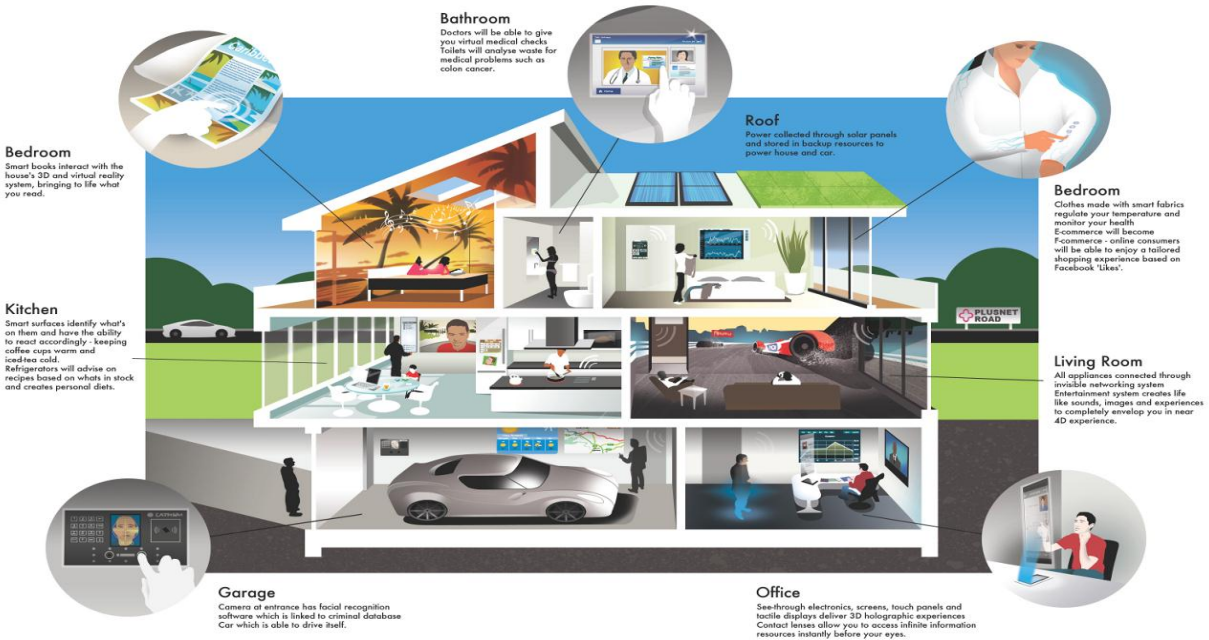

Figure 2.2 Smart Home

The ultimate smart home automation is done by making the electronic components and systems work automatically depending on the need. By integrating the whole household system, we can enhance our life and work with added comfort, savings, convenience and peace of mind.

2.2.1 Importance of Home Automation

The concept of Smart Homes plays an important role in the planning of future housing-based models of care. In today's life, we need home automation for many reasons, such as:

- Tasks that are repetitive in nature can be accomplished automatically
- We can save money by limiting our energy usage and reduce wastage.
- Home automation can increase home safety.
- It saves our time by sharing our responsibilities.
- By using this system we can keep pace with the modern world and can make our life easier.
- Sudden geographical and weather change can be handled well.

2.3 Components for Home Automation

The basic components that are used in home automation system can be categorized as following:

Controlled Devices

Controlled devices include the tremendous range of equipment that a home automation system is capable of controlling. They include household appliances, lighting systems, door openers, power door locks, HVAC systems, power drapes, security systems, telephone systems, intercoms, messaging systems, information systems, and many other types of equipment.

Sensing Devices

Sensing devices can report values, such as light intensity, temperature, humidity, sound levels, etc. or states (such as on, off, open, closed, etc.). The signals sent by sensors are converted into data that can be displayed to the user or used by a controller program to make informed decisions based on certain conditions. The signals can also be converted at the sensor itself. This data is a form of feedback.

Controllers

Controllers provide the intelligent control functions in a home automation system. They can range from a simple lamp timer unit to a smart keypad to a powerful computer. Controllers include any intelligent device capable of sending commands that are understood by the controlled devices.

The control functions may be contained in a single central controller, or there may be other controllers besides the central controller that have a limited subset of control functions.

All controllers must have sufficient data in order to control the controlled devices. Data can come from user input, sensor input, a timer, a control program, or some combination of these. To obtain user input, the system must have one or more user interfaces.

I/O Interface Devices

I/O (input/output) interface devices provide the logical communication link between the controller(s) and the controlled devices in a system. They are the means of making various devices compatible with the physical and logical structure of the system. Most I/O interface devices provide one-way communications from the controller(s) to the controlled devices. An I/O interface device can serve several communications functions, including: Converting analog signals to digital signals that can be used by the controller.

System Network

The system network includes all of the controllers, sensors, wires, cables, RF (radio frequency) links, IR (infrared) links, adapters, connectors, junction boxes, dimmers, ballasts, power supplies, etc. that connect the various system components. In many systems, this is the area that requires the most planning and can be the most labor-intensive part of a total system installation.

Programming Computer

Some system controllers allow the user to program the system with the system's own user interface(s). Other systems require the use of a separate computer (typically a PC) to program the system controller. Still others may allow certain functions to be programmed with the system's own user interface(s), but require a separate computer to program the more advanced functions or change certain basic operating parameters.

2.4 Limitations of Home Automation

Many researchers are currently engaged in developing home automation system integrated with wireless embedded networking. Household chores are being more complex and congested day by day. Human beings have been making things for many thousands of years. Originally most products were made on an individual as-needed basis. But complexity arises with the changes. Though home automation plays an important role in our day to day life, it has some limitations as well. The following points are most prominent.

2.4.1 Installation Costs

It is not a secret that installing a home automation system can be quite costly. But, it all depends on the equipment we wish to have installed. The more advanced system you wish to have in your home the more expensive it will be. This is the most common issue that most homeowners address through automation and remote control. In fact, there are many "starter kits" with pricing less which can provide the owner with several transmitters, a receiver and even options for dialing into the system through a cell phone or PDA. But for reliable home automation system the cost will be higher. For installing a smart home we need sensors, chip, controller etc. The aggregated cost of these equipments is high. Moreover, dedicated home automation specialists are usually being used by the home owners in the present days. The home automation specialists will charge a very high upfront fee to install the system. So the overall cost increases more.

2.4.2 Technological limitations

Current technology is unable to automate all desired tasks. Some tasks cannot be easily automated, such as the production or assembly of products with inconsistent component sizes or in tasks where manual dexterity is

required. Again, Different home should have different types of automation. So the shape and size of the product should be varied for different home. So while producing home automated devices industrially we have to look into these aspects. Sometimes we do not have the same need for same issue. For example, a person who is sick may not need switching the fan on while entering to the room. But the automated home cannot sense it. Here home automation system is increasing work. So fully automated home is not desirable and convenient. There are some things that are best left to human assembly and manipulation.

2.4.3 Human Error

Human error is a deviation from intention, expectation or desirability. From a design perspective the engineer or designer produces a piece of equipment or a system with intentions to function in a certain way. When it doesn't function that way (it breaks, catches on fire, messes up its output or is befallen of some other mishap) they try to find the root cause. If the equipment is not handled & installed safely, this can lead to the equipment being damaged and the risk of the system crashing is high. If the human does not handle the kit safely or if he/she does not use the correct keys to perform the operations, human errors may occur.

Human error includes:

- Failing to perform or omitting a task
- Performing the task incorrectly
- Performing an extra or non-required task
- Performing tasks out of sequence
- Failing to perform the task within the time limit associated with it
- Failing to respond adequately to a contingency

If a switch malfunctions when the operator uses it that is not human error it is a malfunction there is an ongoing debate between ergonomic centered designers and engineering minded designers about human error and design deficiency. On one side is the belief that almost all human error is related to

design deficiency because a good design should take into account human behavior and design out those possibilities while on the other side they believe people make mistakes and no matter what you give them they will find a way to break them. Human errors also lead to destructions of the machine. Then there will be a huge system crash.

2.4.4 Reliability

This occurs on a very rare occasions, depending on the age of the equipment it can have a affect on the system, but otherwise the technology in the home automation systems are all up to date. There has been an increasing interest in home automation over the last few years. In particular, an application such as intelligent illumination, heating, and ventilation which allow reducing the overall energy consumption and improve comfort in our everyday lives mostly depends on the reliability of the product. If there is any damage due to rupturing of cables or the fibers the entire system gets crashed. Here there will be a problem of signal receiving. The wiring of the system results in crash in most of the systems. the reliability of the home-automated devices decreases. It depends mostly on the technology used and the advancements being done.

2.5 Formation of Home automation system

Heating, lighting, ventilation and air conditioning are often controlled via home automation systems, sometimes with excellent energy-saving benefits. Homeowners can regulate temperatures in their entire homes or even in individual rooms or zones. In addition, they can implement a temperature calendar and schedule based on weather predictions, usage patterns or other factors related to HVAC system usage patterns.

At the highest level, home automation systems integrate electrical devices with each other. There are various systems used in home automation, which may be controlled wirelessly or by a hard-wired system connected to the home's electrical grid (this implementation is often present in older systems). In newer home automation schemes, the various systems are often

connected to the home or businesses' computer network, allowing them to be controlled remotely from computers or mobile devices.

There are a number of steps we can take to improve the efficiency of your home and reduce the cost of operations and they're all available via today's highly sophisticated home automation and control systems. The pricing tiers and levels of complexity for individual systems or whole-house installations vary greatly.

2.5.1 Advantages of home automation

Convenience

Convenience is one of the biggest reasons that people build and purchase smart homes. These homes give users remote access to systems including heating and cooling systems, intercoms, music and multimedia devices throughout the home. Integrated hard drives allow homeowners to watch video or listen to audio in any room; video intercoms make it easy to communicate with others in the home or visitors at the door. All of these smart home technologies streamline common tasks. We can manage our home...whether we are actually at home or not! This means we can turn alarms on or off from our smartphone or control multiple audio and video devices with one button. If we want something less hands-on, we can easily set timers to turn lights on or off, turn the temperature up or down...or virtually anything else we can think of. For instance – imagine arriving home every evening to complete comfort. The thermostat has already been adjusted to complement the cool night temperatures perfectly. We sit down and touch one button on an advanced remote that turns on your satellite TV, activates your favorite channel and launches your most used audio preset on your surround sound system.

Security

Smart homes include advanced security systems with cameras, motion sensors and a link to the local police station or a private security company. Smart homes may also use key cards or fingerprint identification in place of

conventional locks, making it harder for someone to break in-home automation security systems make this all possible and easy.

Energy efficiency

Smart homes offer enhanced energy-efficiency. Lights can shut off automatically when no one is in a room, and the thermostat can be set to let the indoor temperature drop during the day before returning it to a more comfortable level just before residents arrive in the evening. All of these automated tasks, along with modern, energy-efficient appliances, combine to save on electricity, water and natural gas, thereby reducing the strain on natural resources. Home automation can pay off, literally, in terms of efficiency and energy savings.

Flexible and future-oriented

A surprising advantage of home automation is that the system is very flexible and future-oriented. The functions of the Bits & Bytes Home System can easily be adapted to the stage of life.. For instance, a family with young children has other needs than a family where the children are living in digs during the week and as a consequence doesn't need to heat those bedrooms.

Chapter 3

Hardware & software implementation

3.1 Objective

The main objective of this project is to create a series of home automation based on Arduino uno. Our target is to create a home automation system which is geographical and climatic convenient, user friendly, modern and fulfills the demand of our country. The Arduino Uno is a microcontroller board based on the ATmega328. These modules are placed in between the target device's electrical plug and the electrical outlet. The modules are then able to control the flow of electricity to the attached device enabling us to turn them on, off, dim and brighten lights, amongst other things.

3.2 Automatic switching of fans and light

Most people leave the fan and lights on when they leave the room. Wasting electricity is caused by leaving things on when they are not being used. This means leaving on lights when we're not in the room, or leaving the TV on or plugged into the mains when we are not in the house. Any outlet plugged into the main socket will draw electricity, so it is the best interest of the household to leave electronics turned off, or unplugged, until it needs to be used. With most chargeable battery items, such as phones, gaming devices and cameras, the battery length will deteriorate if left charging for too long, leading to a shorter battery life with each use. Therefore, once the device is fully charged, it should be removed, and the charger removed from the socket, to stop further waste of electricity. Even leaving an entire house's lights on when only using one room can waste five times as much energy than if you're using all the sockets in only one room. As well as needing to be replaced three times as much as any other electric component, lights use more than twice as

much energy to run daily. To keep the same amount of light entering a room without using energy, one could try keeping the curtains open in certain rooms, to allow natural light to enter the house. This is both free, and is better for your eyes, reducing the strain on the iris to focus on things in low-light conditions. So, we are going to implement an automation system to stop the wastage of electricity.

3.2.1 Components required

Arduino-uno

Microcontroller	ATmega328
Operating Voltage	5V
Input Voltage	7-12V
Input Voltage (limits)	6-20V
Digital I/O Pins	14 (of which 6 provide PWM output)
Analog Input Pins	6
DC Current per I/O Pin	40 mA
DC Current for 3.3V Pin	50 mA
Flash Memory	32 KB of which 0.5 KB used by bootloader
SRAM	2 KB
EEPROM	1 KB
Clock Speed	16 MHz

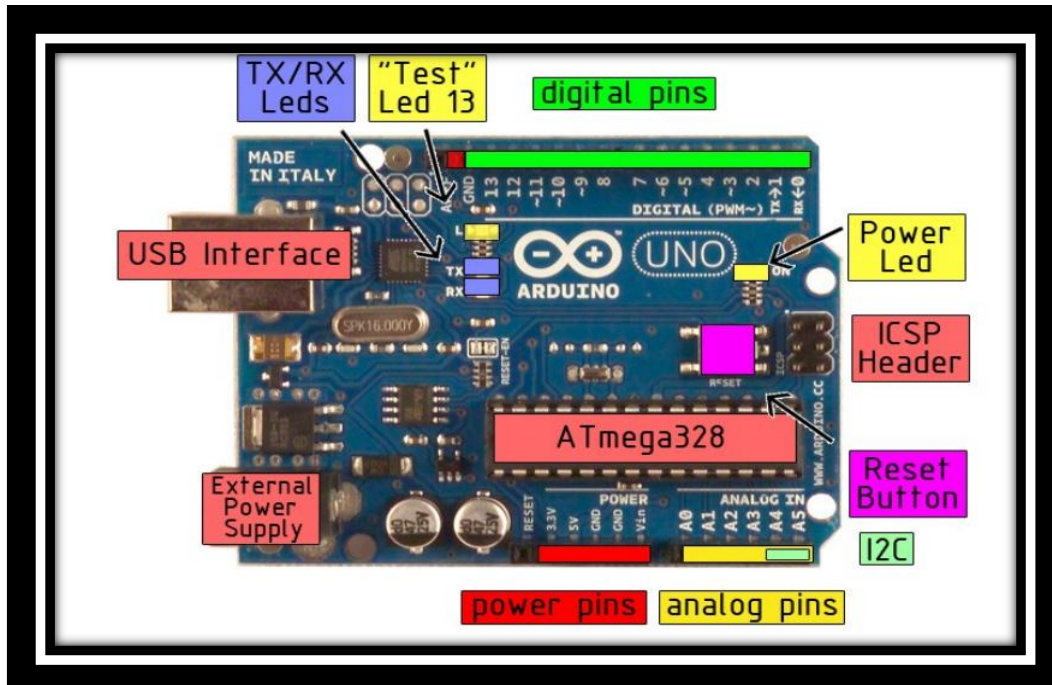

Figure 3.1 Arduino-uno

Infrared Emitters and Detectors

Infrared Emitters and IR Detectors simple devices operate at 940nm and work well for generic IR systems including remote control and touch-less object sensing. Using a simple ADC on any microcontroller will allow variable readings to be collected from the detector. The emitter is driven up to 50mA with a current limiting resistor as with any LED device. The detection is a NPN transistor that is biased by incoming IR light.



Figure 3.2 IR emitter & receiver

Relay

A relay is an electrically operated switch. Many relays use an electromagnet to mechanically operate a switch, but other operating principles are also used, such as solid-state relays. Relays are used where it is necessary to control a circuit by a low-power signal (with complete electrical isolation between control and controlled circuits), or where several circuits must be controlled by one signal.

Here, we will use the relay as a switching device. When the room will be vacant the relay will open the circuit by its operation. Again, it will switch on when someone enters into the room.

And resistors (1K, 10K, 500 Ω , 220 Ω , 100 Ω), wires etc.

3.2.2 Software based Implementation

We are using arduino-uno to implement the automatic switching of lights and switches. Here, fig3.1 shows that someone is entering through the door, thus the Infrared is interfered. But we have to notice whether she is entering or leaving. So, We are using two layers of IR. One IR is at the outer side of the door denoted as IR1 and another is at the inner side of the door denoted as IR2.

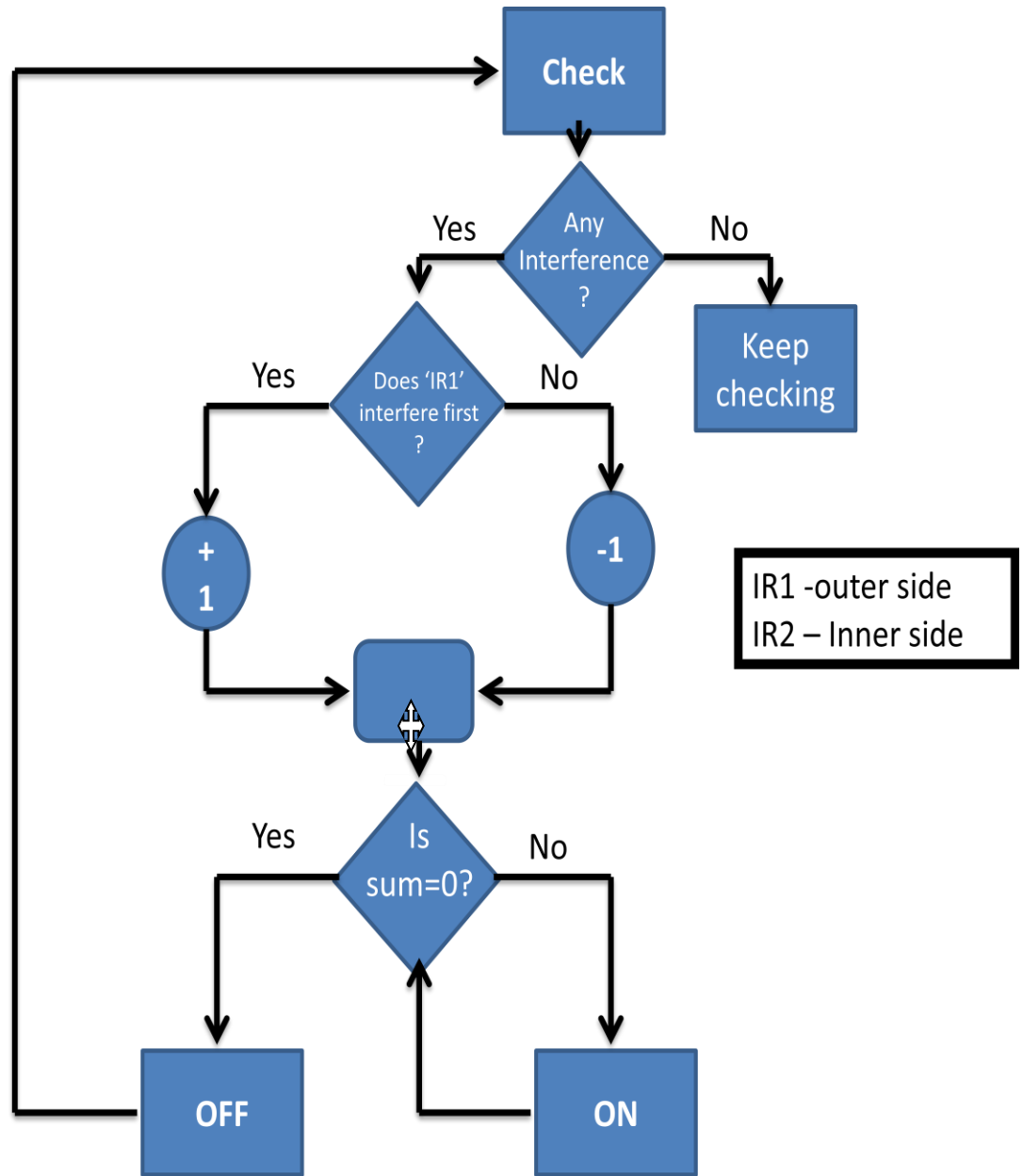

Figure 3.3 Interruption in IR

If IR1 is interfered first, someone is entering into the room. If IR2 is interfered first, someone is leaving.

The fig.3.2 shows the flow chart of automatic switching control depending on number of persons in the room.

F
L
O
W
C
H
A
R
T



Flow chart 3.1 working principle

Explanation

- At first Arduino will continue to check whether there is any interference or not.
- If there is any interference, it will check whether IR1 is interfered first or not.
- If IR1 is interfered first, someone is entering. So, it will count +1
- If IR2 is interfered first, someone is leaving. So, it will count -1
- If sum is not zero, room is not vacant. Switch of the lights and fans will be ON.
- If sum is zero, room is not empty. Switch of the lights and fans will be OFF.
- Again, it will continue to check

Hardware implementation

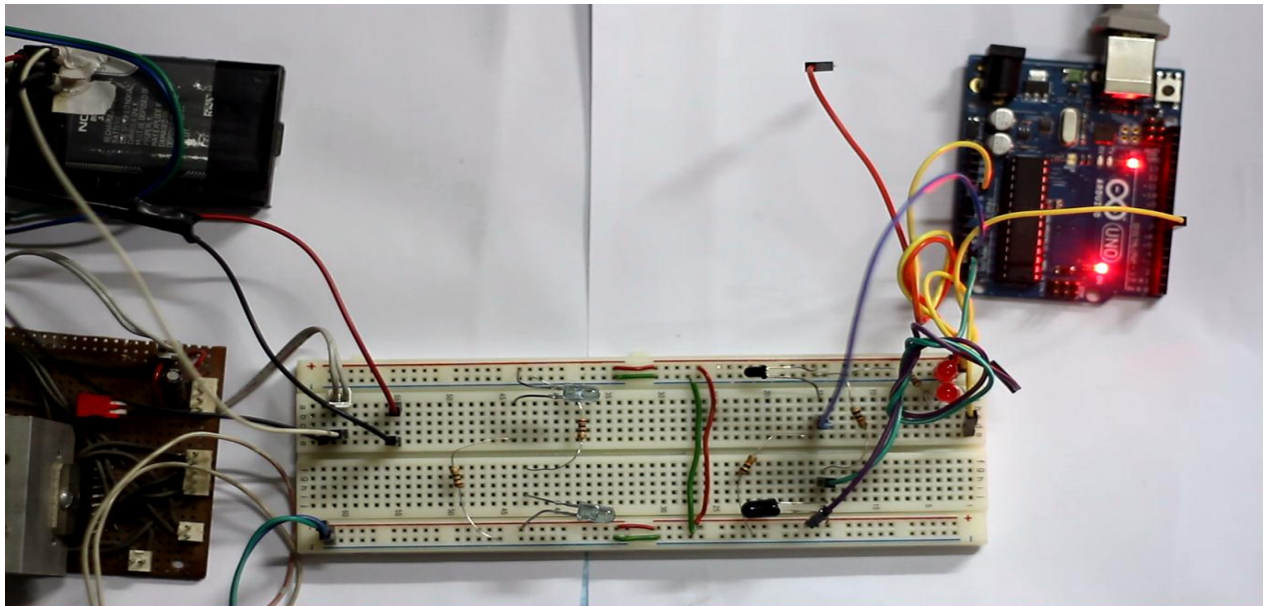

Figure 3.4 Initially the light is off

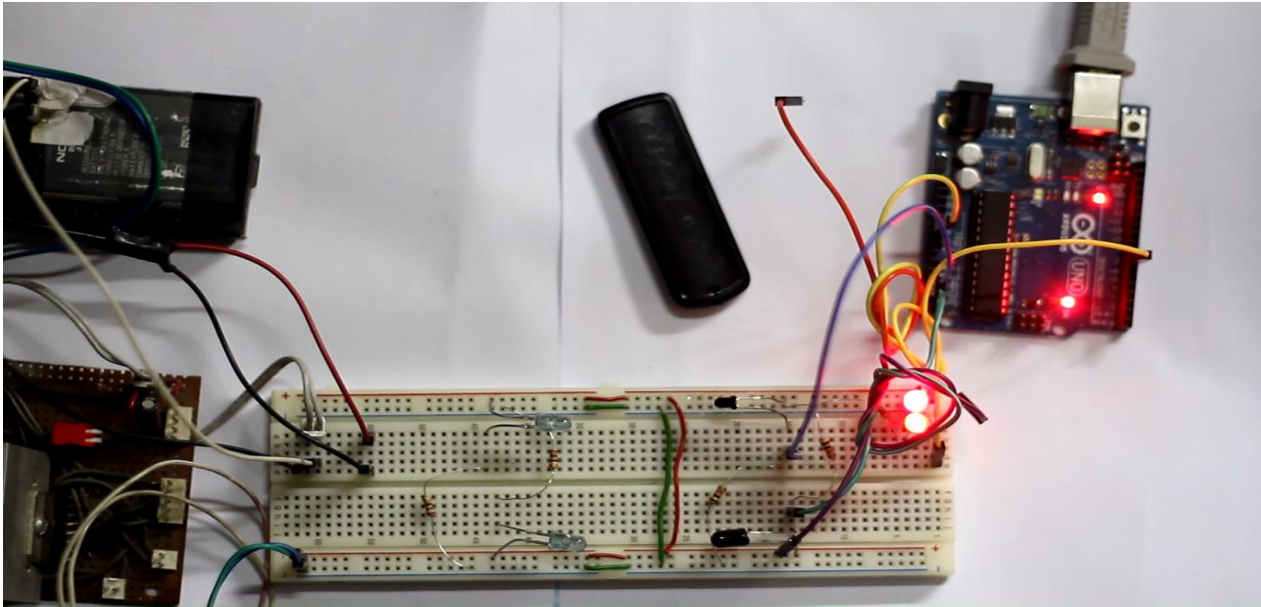

Figure 3.5 When the first person enters, lights on

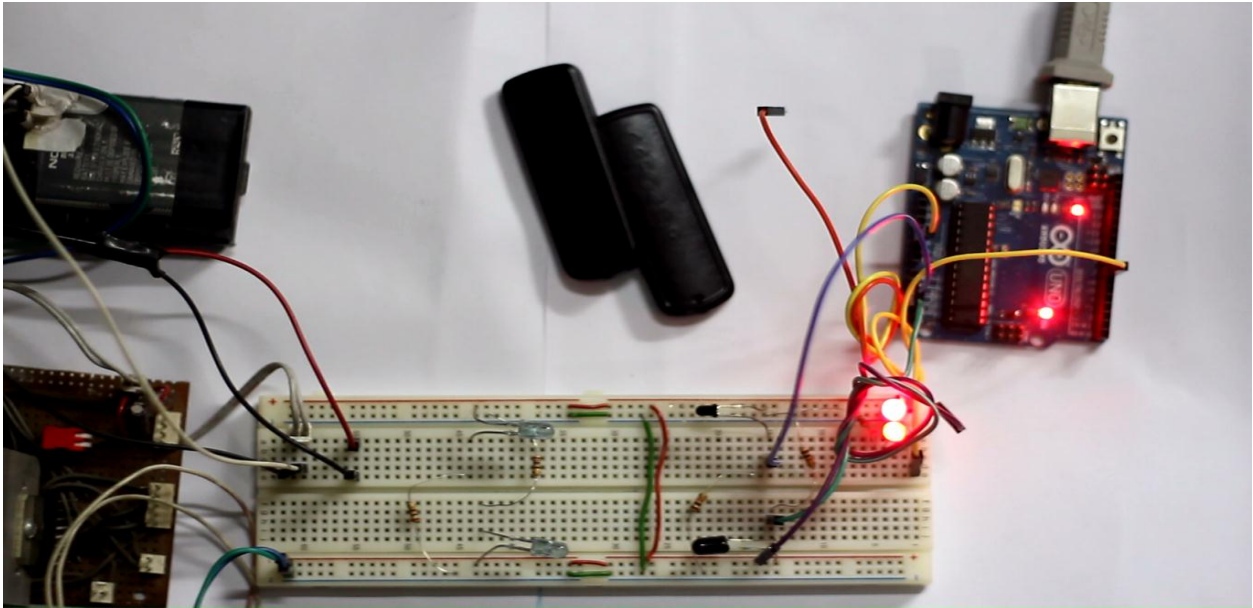

Figure 3.6 Second person enters, lights remain on

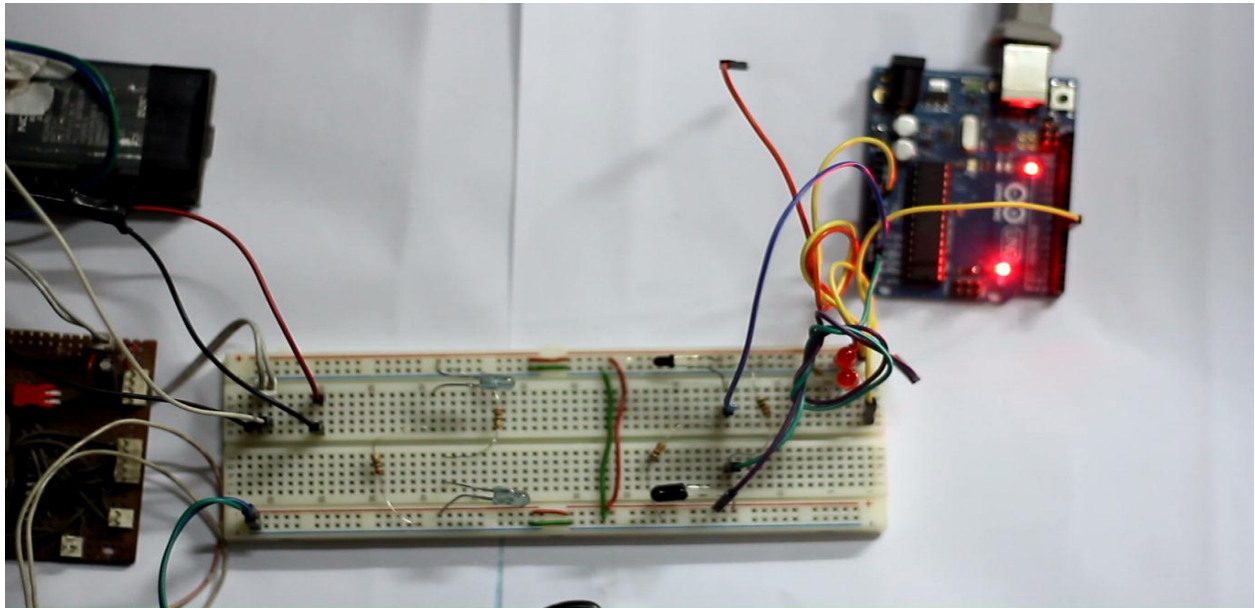

Figure 3.7 When both persons left, lights are off

3.3 Curtain movement control

Electric curtains provide us with the ultimate in convenience. Regardless of how your room is decorated or how our furniture is situated, opening and closing our curtains will be a breeze with the electric curtains. They come in a variety of options, each designed for our convenience and individual needs. For instance, we can have the motor for your electric curtains installed on the left side of the track or the right side and we can also select which side we want to draw the curtains from. It's all about our convenience.

With the constant emphasis on energy efficiency, you'll want to do your part by installing electric curtains in your home. We have your choice of a wall switch, timer & light sensor, remote control or the premier system with the timer, light sensor and remote control. Our idea is based on the sunlight. When sunlight falls upon light sensor, it gives signal to the arduino and arduino drives the motor to open the curtain.

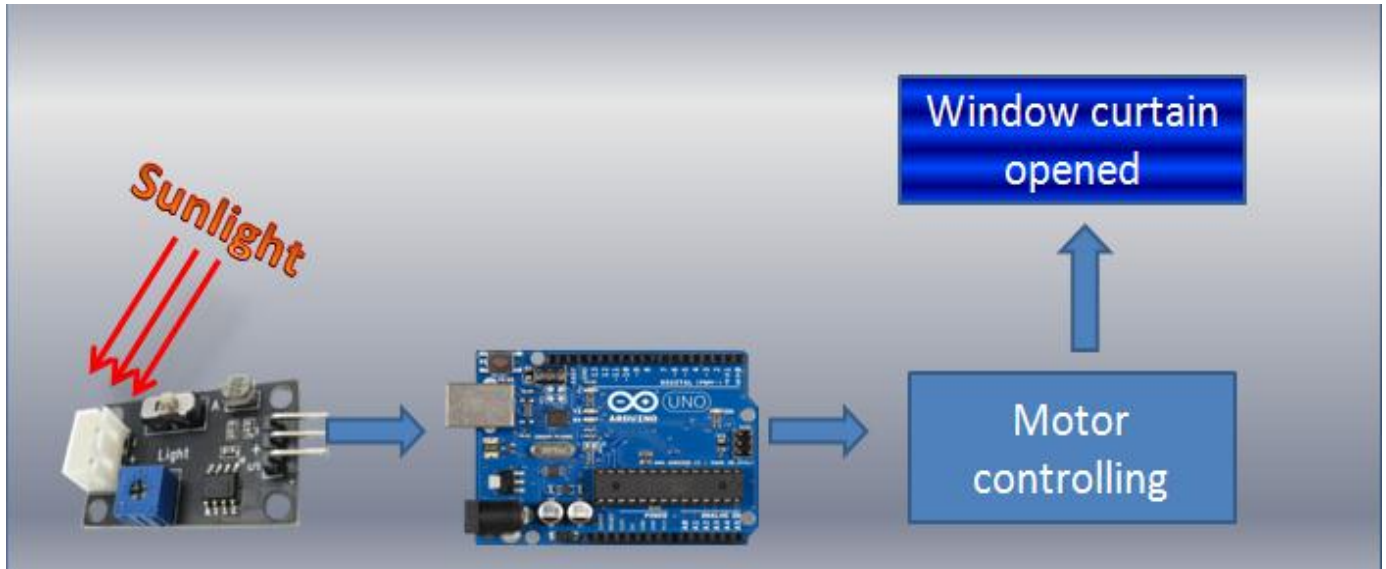

Figure 3.8 curtain movement control

3.3.1 Components required

- Arduino-uno
- Light sensor
- Motor drive
- Heat sink
- Low speed high torque motor

Light sensor

A Light Sensor generates an output signal indicating the intensity of light by measuring the radiant energy that exists in a very narrow range of frequencies basically called “light”, and which ranges in frequency from “Infra-red” to “Visible” up to “Ultraviolet” light spectrum.

The Light Sensor is a passive devices that convert this “light energy” whether visible or in the infra-red parts of the spectrum into an electrical signal output. Light sensors are more commonly known as “Photoelectric Devices” or “Photo Sensors” because the convert light energy (photons) into electricity (electrons). Here we will use the light sensor to measure the intensity of sunlight and control the window curtain accordingly.

Arduino code

```
int sensor_1;//initiating the water sensor
int sensor_2;//initiating IR1
int sensor_3;//initiating IR2
int count=0;//starting counter for no of persons in the room
int ledpin=13;//initialization

int thresh1=850;//threshold for IR1
int thresh2=850; //threshold for IR2
int thresh3=500; //threshold for water sensor

int a =0;//initialization
int b=0;// initialization
int interval=1000;
int n=0;
int starttime;
void setup()
{
  Serial.begin(9600);//default serial
  pinMode(motorf,OUTPUT);//Motor off
  pinMode(ledpin,OUTPUT);//output
  pinMode(motoren,OUTPUT);//Motor enable
}

void loop()
{
  get_sensor_values();
  Serial.print(sensor_1);
  Serial.print("\t");//water sensor reading
  Serial.print(sensor_2);
  Serial.print("\t");//IR1 reading stored
  Serial.print(sensor_3);
  Serial.print("\t");//IR2 reading stored
  Serial.print(count);
  Serial.println();
  while((sensor_1 <= thresh1) || a==1 )// initiating loop
```

```
{
  a=1;//initialization
  get_sensor_values();//sensor values
  if(sensor_2 <= thresh2 )//check
  {
    a=0;
    b=0;
    count=count+1;//someone is entering
    break
  }
}
while((sensor_2 <= thresh2) || b==1 )// checking the sensor value
{
  get_sensor_values();//sensor values
  b=1;
  if(sensor_1 <=thresh1 )//check whether he is leaving
  {
    a=0;
    b=0;
    count=count-1;//subtract 1 when he is leaving
    break;
  }
}
if(sensor_3 > thresh3)//checking the water sensor value
{
  get_sensor_values();// stored the sensor value
  starttime = millis();
  while (millis()-starttime >=interval)//while greater than threshold
  {
    digitalWrite(ledpin,HIGH);//pin is high
    motor_forward();//motor runs in forward direction
    n=1;
  }
  digitalWrite(ledpin,LOW);//motor pin will be low during rain
  motor_stop();//motor will be stopped when it continues to rain
  starttime=0;
}
if((sensor_3 < thresh3 ) && n==1)//lower than threshold
{
  get_sensor_values();//getting sensor values
```

```
    starttime = millis();
    while ((millis()- starttime >=interval) )//if lower than threshold
    {
        //motor_backward();
        digitalWrite(ledpin,LOW);//initially pin will be low
        delay(250);//delay
        digitalWrite(ledpin,HIGH);//pin will be high so backward rotation
    }
    digitalWrite(ledpin,LOW);//motor will be stopped
    starttime=0;
    n=0;
    motor_stop();
}
delay(100);
}
void get_sensor_values(void)
{
    sensor_1=analogRead(A0);//take the reading of IR1
    sensor_2=analogRead(A1); //take the reading of IR2
    sensor_3=analogRead(A2);//take the reading of the water sensor
}
void motor_forward()
{
    digitalWrite(motoren,HIGH);//enabling the motor pin
    digitalWrite(motorf,HIGH);//motor in forward direction
    digitalWrite(motorb,LOW);//motor in backward direction
}
void motor_backward()
{
    digitalWrite(motoren,HIGH);
    digitalWrite(motorf,LOW);
    digitalWrite(motorb,HIGH);
}
void motor_stop()
{
    digitalWrite(motoren,LOW);
    digitalWrite(motorf,LOW);
}
}
```

3.4 Counting the number of people in the room

Two laser beams, one just outside the door and the other just inside the room to count the number of persons entering or leaving the room.

Advantages

- The number of persons entering or leaving can be monitored automatically.
- Without counting manually we can have an accurate calculation of number of people of any place like classroom, stadium, museum etc
- The counting information can be used in automatic switching.
- If the counting is zero, then cutting the power off, we can save usage of energy.

Components

1. Arduino-uno
2. LCD display
3. Laser
4. Wires

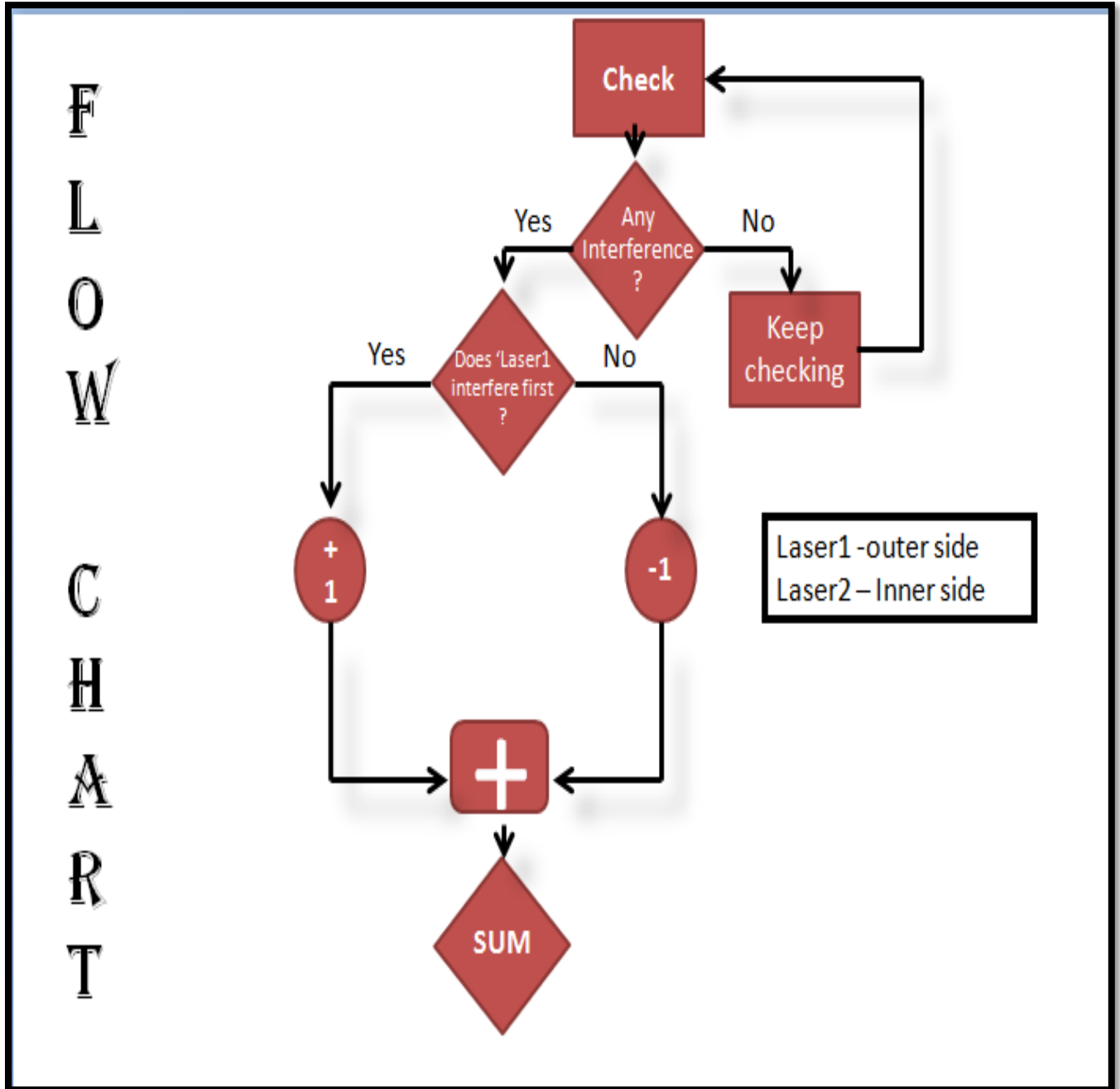

Flow chart 3.2 counting the number of people

Explanation

- At first Arduino will continue to check whether there is any interference or not.
- If there is any interference, it will check whether Laser 1 is interfered first or not.
- If Laser 1 is interfered first, someone is entering. So, it will count +1
- If Laser 2 is interfered first, someone is leaving. So, it will count -1
- If sum is not zero, room is not vacant.
- If sum is zero, room is vacant.
- It will give the reading to the LCD display

3.5 Automatic control of window

Water sensor will sense whether is raining or not. The window will be closed automatically during rain continues. The window will be opened automatically when the rain stops.

Components

- Arduino-uno
- Water sensor
- Servo motor
- Heat sink
- Power supply

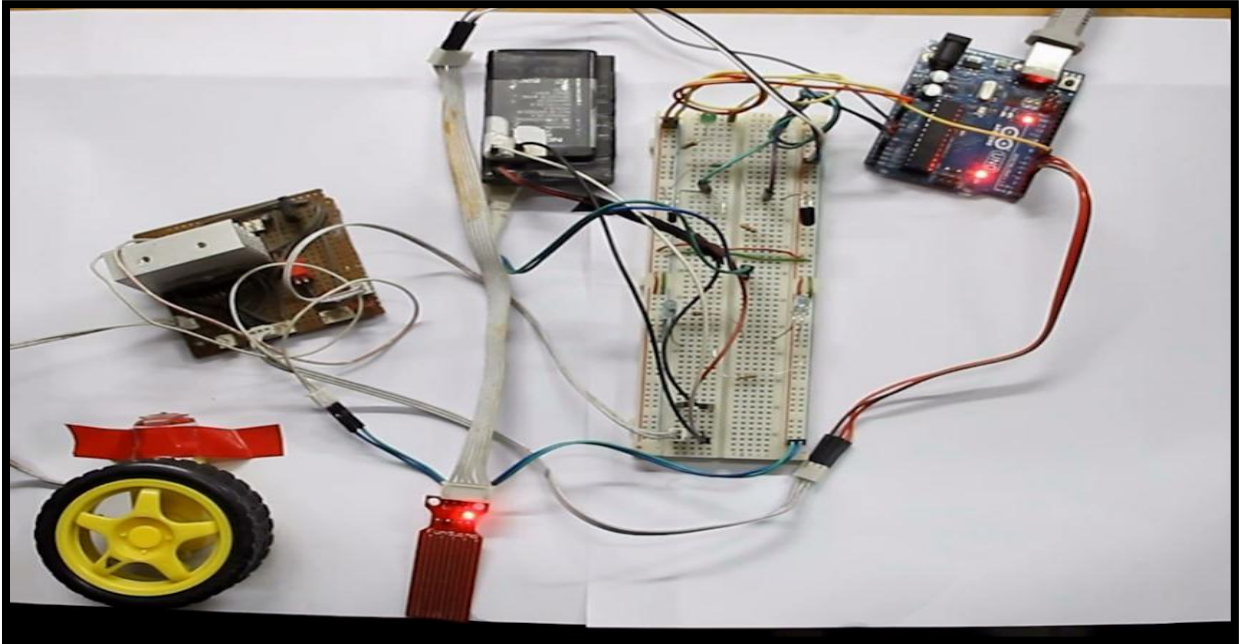

Figure 3.9 Arrangement of components with sensor, wheel, power supply, Arduino-uno

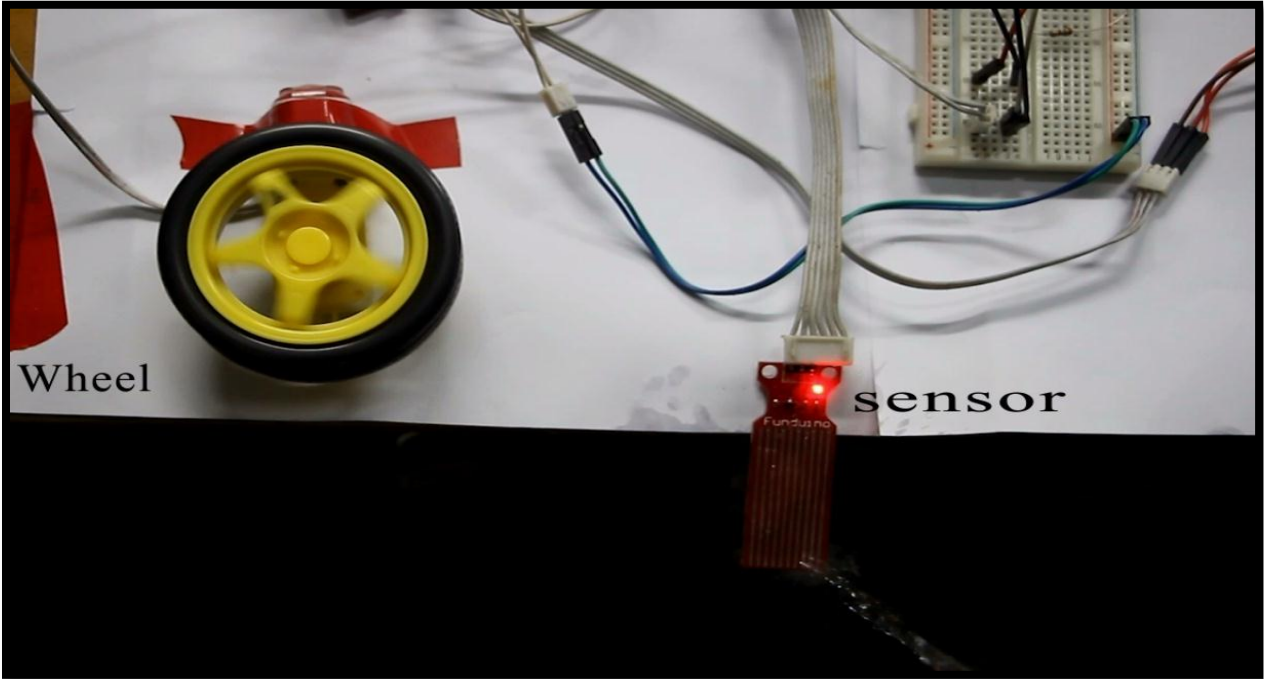

Figure 3.10 Wheel rotates clockwise when water falls on sensor and rotates anticlockwise direction when water is stopped.

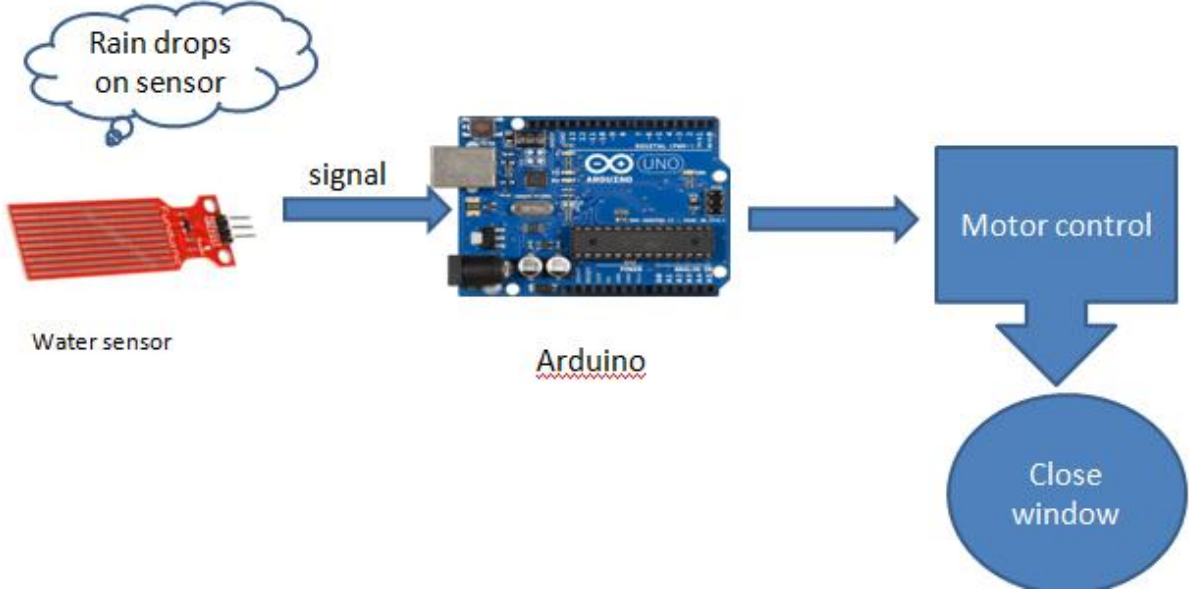

Figure 3.11 Automatic window control

Chapter 4

4.1 More possibilities

Technological advancement has made the implementation of embedded systems within home appliances possible. Now a day, most of the people are in touch with web or mobile communication. This has added new capabilities and features in the field of home automation. However, most of the time, the implementations are proprietary and networking is not always possible due to some problems. Yet there is an increasing demand for smart homes, where appliances react automatically to changing environmental conditions and can be easily controlled through one common device. We can show a possible solution whereby the user can control devices easily by employing an embedded system to which the devices and sensors are interfaced. This results in a simple, cost effective, and flexible system, making it a good candidate for future smart home solutions.

Home automation can include following ways to control the home appliances.

- Global system for mobile communication (GSM)
- Remote controller
- Web enabled controller and so on

4.2 Home Automation System using GSM module

Today, mobile phone is an important part of our life. So it's best possible way if we can interconnect our home appliances with mobile based control. GSM is the most popular standard for mobile phones in the world. GSM controlled home automation systems are widely used in the world. Our basic home appliances can be easily controlled via GSM network. But the main thing is to cope up with the cost. That is why, it's best to use our own GSM module

to integrate with our required appliances. Main components that can be used are:

- GSM module
- DTMF (dual tone multi frequency) signaling
- DTMF decoder
- Arduino
- Relay
- Required complete circuit

DTMF is used in telecommunication between handset and other communication devices. To match the arduino low power with the high power real network, relay is used. As GSM module has built in RS232 chip, it can easily communicate with the controller arduino. The whole setup is in such a way that it contains proper atmosphere and safe instrumentation. Thus, the system presents a mobile controller and user friendly approach to the home automation system.

Advantages

- GSM is easy to access and use, portable, and has a global range.
- It can make our life easier.
- Home appliances can be controlled from far distance.
- Portability
- Low power consumption
- SMS (short message service) can be used as command.

Disadvantages

- No feedback is provided
- If the main chip/device fails, it leads to a catastrophe.

4.3 Home Automation using Remote Controller

Wireless technologies represent a rapidly emerging area of growth and importance for providing ubiquitous access to the network. Remote controller is a good way to use as a control device for home automation system. Many types of remote controllers can be used here; such as TV remote, IR remote etc.

4.3.1 HAS using IR remote

A completely automated smart home system can be implemented by using an unused remote controller. In this case, control head receives an IR signal using an IR receiver chip. Here, remote controller is used to send signals and it senses the necessity by sensing the signals sent from remote instead of using sensor inputs. To implement the whole system, a remote controller with numerical buttons can be chosen. Then an IR receiver is needed to be integrated with the main chip with the ability of decoding 35 KHz to 40 KHz IR signals. Once implemented, we can use the controller to control home automation system from a distance manually.

A normal TV remote can also be used to control the automated home. As TV remote has built in IR sensors in it, it can be easily used with the same principle as previous section.

4.4 HAS using Bluetooth

As people have easy access to Bluetooth because of their smart phones, it's preferable to use Bluetooth rather than using remotes in home automation also. Main advantages of using Bluetooth are:

- Easy access and use
- More secured

- Works in short distance range (10m max)
- Anyone can find free Bluetooth in their smart phones.

So, if we want to have a simple system with reliable control then using Bluetooth is a better option.

Basic components that can be used here are:

- HC-05 Bluetooth module
- Power supply
- Arduino
- Smart phone (android)
- Resistors, Capacitors

The Module that can be used here is a Serial Port Protocol (SPP) module designed for a transparent serial connection setup. Using potentiometer, we can get the required output for the Bluetooth module.

Basic algorithm can be as such:

The system simply receives instructions from Bluetooth enabled smart phone using the module and pass it to the arduino which does the main processing part. When the arduino gets the input signal via Bluetooth, it switches ON or OFF the relay and relay works as a switching device for the AC appliances. Thus, we can control our automation via Bluetooth using a smart phone.

4.5 HAS using web interface

We can integrate the automation system using web browser as well. We can check out the home appliances using web browser and even can command it to do something form a distant place.

The basic idea is to turn a normal router as a home automation server. It will allow us to send out serial commands remotely. The simple principle is to send command using a web browser to the router. Upon getting the command, the router will send specific input signal to the receiver and thus the control

arduino will do as commanded. Basic components that are needed on this purpose are:

- Open WRT compatible router with serial header
- Actuators like RF switches outlets
- Arduino
- RF receiver
- Particularly designed webpage (optional)

The Router runs a web server, that we can access via browser. After pushing a button on the web page the router sends out a serial command, we process this with arduino which converts it to RF protocol, injects it into the RF remote, which controls the RF outlets.

There are some disadvantages too. Such as:

- Comparatively unsecured
- It requires several internet protocol and user information etc.

In contrast to devices controlled from a web browser these are designed to be simple. Arduino based devices that are capable of talking to each other bi-directionally. It's possible to have local Device/Relay combinations to control Mains socket power to the appliances. Practically, it is a good idea to have one device per room.

4.6 Interconnected System

Home automation is an interconnected system that includes every home appliance. After being able to control all rooms in a house automatically, we can take all of them under the command of a master device. This master device can have ultimate control over all the arduino at a time. The total system can be integrated by using: one arduino for each room, a master arduino (may be arduino MEGA) to take over all other arduinos, jumper wires and related circuits. Only the main arduino will be connected to the main power supply of the house and others will be connected individually to power line specified to each room. Then every room is controlled by one arduino and

all of them will be answerable to the master arduino which will make the ultimate decision.

4.7 Security incorporated in System

As it is said, there is no substitute for peace of mind. The first prior thing comes in our mind is security of ourselves. And a secured home is essential for that. In that case, we have opportunity to include security automation to our home automation system. Security automation will provide us the possibility to make our home both comfortable and secured. For that purpose, we have to add two things in our system. We can either take already burned arduino chip that contains security program for our home or we can extend our own system to security level such as adding a digital coded lock in our automated doors and windows. We can also add this system to our following home appliances:

- Door lock
- Fire alarm
- Smoke detector and so on

We have to incorporate it with our system by using another arduino connected with/without wire and have to monitor the security system by using a computer or smart phone alarm.

4.3.8 Making Own Device/Product

If we can design all the required appliances, we can take the burned chip and use it to make a small device. We can make the PCB design and implement it in a PCB board. Then it's very easy to connect to the whole system in a house. And thus we can make a cheap, effective home automation device

Chapter 5

Conclusion

Home automation is a technical system that isn't very familiar to people in our country. A home automation system integrates electrical devices in a house with each other. The techniques employed in home automation include those in building automation as well as the control of domestic activities. As the number of controllable devices in the home rises, interconnection and communication becomes a useful and desirable feature. Home automation can also provide a remote interface to home appliances or the automation system itself, to provide control and monitoring on a smartphone or web browser. Home automation technologies are viewed as integral additions to the smart grid. Communication between a home automation system and the grid would allow applications like load shedding during system peaks or would allow the homeowner to automatically defer energy use to periods of low grid cost. The whole system can be incorporated with GSM, Universal access of appliances in smart home with energy usage limit where applicable.

In modern construction in industrialized nations, most homes have been wired for electrical power, telephones, TV outlets (cable or antenna), and a doorbell. Many household tasks were automated by the development of specialized automated appliances. In this thesis work, our target was to accomplish the goal to take simple home appliances under automated control and the whole system to be integrated. However, we have done the projects and found the way to incorporate with it in future.

Furthermore, we tried to reach the optimum point of operation integrating all the projects together so that we can control the whole system with only one arduino.

References

- Harper, Richard, ed. (14 August 2003). *Inside the Smart Home*. Springer. ISBN 1852336889.
- "Home automation costs". Totalavcontrol.co.uk. Retrieved 2010-02-18.
- 1.5 Million Home Automation Systems Installed in the US This Year, ABI Research
- Griffiths, Melanie (March 2008). "Smart Home Security". *Homebuilding & Renovating*. Retrieved 27 February 2012.
- "Market Outlook: Worldwide Domotics and Home Automation Market evolution, 2010-2016". CMT research. Retrieved 2012-10-26.
- The Specification, Design, and Implementation of a Home Automation System, Javier Castro and James Psota{javy,psota}@mit.edu6.111: Introductory Digital Systems Laboratory Final Project,Massachusetts Institute of Technology
- Arduin Uno: <http://www.amazon.com/Arduino-UNO-board-DIP-ATmega...>
- Servo: [https://www.hobbyking.com/hobbyking/store/_25456 ...](https://www.hobbyking.com/hobbyking/store/_25456...)