

# **Accessible Design and Fabrication of Wheelchair Ramp for Public Bus Transportation and Design Study Based on SolidWorks Simulation**

---

A DISSERTATION SUBMITTED IN PARTIAL FULFILLMENT OF REQUIREMENT FOR THE DEGREE  
OF BACHELOR OF SCIENCE IN MECHANICAL AND CHEMICAL ENGINEERING

**ISLAMIC UNIVERSITY OF TECHNOLOGY (IUT)  
THE ORGANIZATION OF ISLAMIC CONFERENCE (OIC)**



**SUBMITTED BY**

**SYED TASNIM AHMED (STUDENT NO: 131446)**

**SAKIB UL ISLAM (STUDENT NO: 131460)**

**UNDER THE SUPERVISION OF**

**DR. A R M HARUNUR RAHSID**

**ASSISTANT PROFESSOR**

**DEPARTMENT OF MECHANICAL AND CHEMICAL ENGINEERING**

**ISLAMIC UNIVERISTY OF TECHNOLOGY (IUT)**

## **CERTIFICATE OF RESEARCH**

The thesis title “Accessible Design and Fabrication of Wheelchair Ramp for Public Bus Transportation and Design Study Based on SolidWorks Simulation” submitted by SYED TASNIM AHMED (131446) and SAKIB UL ISLAM (131460), has been accepted as satisfactory in partial fulfillment of the requirement for the Degree of Bachelor of Science in Mechanical and Chemical Engineering on November, 2017.

Supervisor

-----

Dr. ARM Harunur Rashid

Assistant Professor

Department of Mechanical and Chemical Engineering (MCE)

Islamic University of Technology (IUT)

Gazipur, Dhaka

## DECLARATION

THIS IS TO CERTIFY THAT THE WORK PRESENTED IN THE THESIS IS AN OUTCOME OF THE ANALYSIS SIMULATION AND RESEARCH CARRIED OUT BY THE AUTHOR THEMSELVES UNDER THE WATCHFUL SUPERVISION OF DR. ARM HARUNUR RASHID. EACH OF THE AUTHORS CONTRIBUTED EQUALLY IN FULFILLMENT OF THE THESIS PROJECT.

-----  
SYED TASNIM AHMED (131446)  
(Author)

-----  
SAKIB UL ISLAM (131460)  
(Author)

-----  
DR. ARM HARUNUR RASHID  
(Project supervisor)

## **ACKNOWLEDGEMENT**

We would like to thank Dr. ARM Harunur Rashid from our deepest of our heart for the close supervision and guidance. He dedicated his valuable time and effort to solve our problem and guided us in such a way which is beyond imagination. His vast knowledge on the topic enhanced our venture to a great extent. Last but not the least we express our gratitude to ALLAH, THE ALMIGHTY.

## TABLE OF CONTENTS

<b>CERTIFICATE OF RESEARCH</b>	<b>2</b>
<b>DECLARATION</b>	<b>3</b>
<b>ACKNOWLEDGEMENT</b>	<b>4</b>
<b>LIST OF FIGURES</b>	<b>9</b>
<b>LIST OF ACRYNOMS</b>	<b>11</b>
<b>ABSTRACT</b>	<b>12</b>
<b>CHAPTER 1</b>	<b>13</b>
<b>1.1 Introduction</b>	<b>13</b>
<b>1.2 Background</b>	<b>14</b>
<b>1.3 Previous Ramp Research</b>	<b>14</b>
<b>1.4 Scope of Project</b>	<b>16</b>
<b>1.5 Parameters Considered</b>	<b>16</b>
<b>1.6 Project Goals</b>	<b>17</b>
<b>CHAPTER 2</b>	<b>18</b>
<b>2.1 Methodology</b>	<b>18</b>
2.1.1 Factor of Safety	18
2.1.2 Stress Analysis	18
2.1.3 Displacement Analysis	19
<b>2.2 Design Concept and Approach</b>	<b>19</b>
2.2.1 Accessible Design	19
2.2.2 ADA guideline	19
2.2.3 Initial Design Consideration	20
<b>2.3 Dimension of the Ramp</b>	<b>20</b>
<b>2.4 Safety Features</b>	<b>21</b>
<b>CHAPTER 3</b>	<b>22</b>
<b>3.1 Initial Design Using SolidWorks</b>	<b>22</b>
3.1.1 3D view of the parts and assembly:	22

3.1.2	Drawing of the parts	27
<b>CHAPTER 4</b>		<b>30</b>
<b>4.1</b>	<b>Design Study based on SolidWorks Simulation</b>	<b>30</b>
4.1.1	Design Study for the following materials	30
4.1.2	Loads	30
4.1.3	Loads and Fixtures	31
4.1.4	Fixed Geometry	32
4.1.5	Meshing	32
<b>CHAPTER 5</b>		<b>33</b>
<b>RESULTS</b>		<b>33</b>
<b>5.1</b>	<b>Design Study 01</b>	<b>33</b>
5.1.1	Model Information	33
5.1.2	Material Properties	33
5.1.3	Study Results (Stress)	34
5.1.4	Study Results (FOS)	35
5.1.5	Study Results (Displacement)	36
<b>5.2</b>	<b>Design Study 02</b>	<b>37</b>
5.2.1	Model Information	37
5.2.2	Material Properties	37
5.2.3	Study Results (Stress)	38
5.2.4	Study Results (FoS)	39
5.2.5	Study Results (Displacement)	40
<b>5.3</b>	<b>Design Study 03</b>	<b>41</b>
5.3.1	Model Information	41
5.3.2	Material Properties	41
5.3.3	Study Results (Stress)	42
5.3.4	Study Results (FOS)	43
5.3.5	Study Results (Displacement)	44
<b>5.4</b>	<b>Design Study 04</b>	<b>45</b>
5.4.1	Model Information	45
5.4.2	Material Properties	45
5.4.3	Study Results (Stress)	46
5.4.4	Study Results (FoS)	47
5.4.5	Study Results (Displacement)	48
<b>5.5</b>	<b>Graphical presentation of the results</b>	<b>49</b>
<b>CHAPTER 6</b>		<b>51</b>
<b>FABRICATION</b>		<b>51</b>

<b>6.1 Materials Used in Different Parts</b>	<b>51</b>
<b>6.2 Why Plywood</b>	<b>51</b>
6.2.1 Plywood vs Balsa wood	51
<b>6.3 Fabricated Parts</b>	<b>52</b>
<b>CHAPTER 7</b>	<b>54</b>
<b>CONCLUSION</b>	<b>54</b>
<b>CHAPTER 8</b>	<b>55</b>
<b>REFERENCES</b>	<b>55</b>

## LIST OF TABLES

TABLE 1 RAMP SLOPE	20
TABLE 2 DS 1 MODEL INFORMATION	33
TABLE 3 DS 1 MATERIAL PROPERTIES	33
TABLE 4 DS 1 STRESS ANALYSIS	34
TABLE 5 DS 1 FOS ANALYSIS	35
TABLE 6 DS 1 DISPLACEMENT ANALYSIS	36
TABLE 7 DS 2 MODEL INFORMATION	37
TABLE 8 DS 2 MATERIAL PROPERTIES	37
TABLE 9 DS 2 STRESS ANALYSIS	38
TABLE 10 DS 2 FOS ANALYSIS	39
TABLE 11 DS 2 DISPLACEMENT ANALYSIS	40
TABLE 12 DS 3 MODEL INFORMATION	41
TABLE 13 DS 3 MATERIAL PROPERTIES	41
TABLE 14 DS 3 STRESS ANALYSIS	42
TABLE 15 DS 3 FOS ANALYSIS	43
TABLE 16 DS 3 DISPLACEMENT ANALYSIS	44
TABLE 17 DS 4 MODEL INFORMATION	45
TABLE 18 DS 4 MATERIAL PROPERTIES	45
TABLE 19 DS 4 STRESS ANALYSIS	46
TABLE 20 DS 4 FOS ANALYSIS	47
TABLE 21 DS 4 DISPLACEMENT ANALYSIS	48
TABLE 22 MATERIAL COMAPRISON	49
TABLE 23 PHYSICAL PROPERTIES OF PITALI AND MARKET PLYWOOD	51



## LIST OF FIGURES

FIGURE 1. PERCENTAGE DISTRIBUTION OF POPULATION BY DISABILITY STATS AND TYPES	13
FIGURE 2 CHANNEL 3D	22
FIGURE 3 SLIDER HINGE WITH WHEEL 3D	22
FIGURE 4 RAMP BODY 3D	23
FIGURE 5 RAMP BODY BACK VIEW	23
FIGURE 6 RAMP BODY SIDE VIEW	23
FIGURE 7 RAMP BODY BOTTOM VIEW 3D	23
FIGURE 8 RAMP WITH SLIDER WHEEL 3D	24
FIGURE 9 RAMP WITH SLIDER WHEEL BACK VIEW 3D	24
FIGURE 10 RAMP WITH SLIDER WHEEL BOTTOM VIEW 3D	24
FIGURE 11 FRONT AND BACK SUPPORT FOR THE ASSEMBLY 3D	25
FIGURE 12 CHANNEL ASSEMBLY 3D	25
FIGURE 13 RAMP-CHANNEL ASSEMBLY INSTALLED ON STAIRS AND PEDESTRIAN 3D	26
FIGURE 14 RAMP-CHANNEL ASSEMBLY INSTALLED ON BUS 3D	26
FIGURE 15 CHANNEL DRAWING	27
FIGURE 16 SLIDER HINGE WITH WHEEL DRAWING	28
FIGURE 17 RAMP BOARD DRAWING	29
FIGURE 18 DS 1 STRESS ANALYSIS	34
FIGURE 19 DS1 FOS ANALYSIS	35
FIGURE 20 DS 1 DISPLACEMENT ANALYSIS	36
FIGURE 21 DS 2 STRESS ANALYSIS	38
FIGURE 22 DS 2 FOS ANALYSIS	39
FIGURE 23 DS 2 DISPLACEMENT ANALYSIS	40
FIGURE 24 DS 3 STRESS ANALYSIS	42
FIGURE 25 DS 3 FOS ANALYSIS	43
FIGURE 26 DS 3 DISPLACEMENT ANALYSIS	44
FIGURE 27 DS 4 STRESS ANALYSIS	46
FIGURE 28 DS 4 FOS ANALYSIS	47
FIGURE 29 DS 4 DISPLACEMENT ANALYSIS	48

FIGURE 30 GRAPHICAL PRESENTATION OF WEIGHT OF THE RAMP FOR STUDIED MATERIALS	49
FIGURE 31 GRAPHICAL PRESENTATION OF MINIMUM FOS OF THE RAMP FOR STUDIED MATERIALS	50
FIGURE 32 GRAPHICAL PRESENTATION OF MAXIMUM STRESS OF THE RAMP FOR STUDIED MATERIALS	50
FIGURE 33 GRAPHICAL PRESENTATION OF MAXIMUM DISPLACEMENT OF THE RAMP FOR STUDIED MATERIALS	50
FIGURE 34 RAMP BODY	52
FIGURE 1 SLIDER HINGE AND RAMP ASSEMBLY	50
FIGURE 36 SLIDER HINGE	52
FIGURE 37 SLIDER	53
FIGURE 38 FULL ASSEMBLY	53

## LIST OF ACRONYMS

<b>ADA</b>	Americans with Disabilities Act
<b>ADAAG</b>	Americans with Disabilities Act Accessibility Guidelines
<b>FoS</b>	Factor of Safety
<b>FEA</b>	Finite Element Analysis
<b>DS</b>	Design Study

## **Abstract**

There are an estimated 5.6% people in Bangladesh who have a disability of one kind or another and about 28% of disabled people have physical disabilities. Movement accessibility is an important enabler of strategies to fight poverty through enhancing access to education, employment, and social services. However there is no special facilities for the disabled people in Bangladesh in the transportation sector. People using wheelchair find hard to embark and disembark into a public transport. This paper represents the design parameter and fabrication of wheelchair ramp for persons with physical disabilities for public bus transportation. The design of the ramp is based upon the guidelines of ADA. Design Study was conducted for different material on SolidWorks Simulation However regarding the present situation in Dhaka city there is some limitation regarding the dimensions of the ramp in the practical application. Some solution was suggested to eliminate the limitation.

# CHAPTER 1

## 1.1 Introduction

Many people with mobility impairments are dependent on public transportation for completing instrumental activities of daily living, participating in social activities, or engaging in recreational opportunities. In reducing poverty improved access and mobility are considered as most important factors. People with disabilities are 2.5 times more likely to experience transportation difficulties than able-bodied people (National Council on Disability 2005). Many countries have legislation requiring that these challenges be addressed but in Bangladesh, effective responses are generally very limited. Action to improve the situation is constrained by the serious shortage of data on the access and mobility needs of disabled and elderly people as well as by resource constraints.

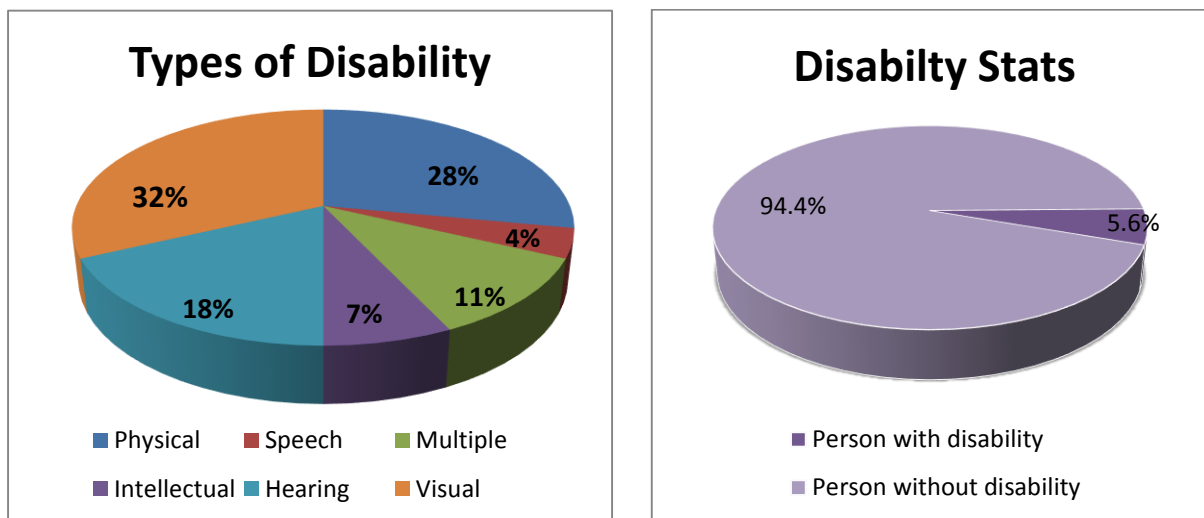

Figure 1 Percentage distribution of population by disability stats and types

People using wheelchair find hard to embark and disembark into a public transport. Use of wheelchair ramp is an essential feature for the easy movement of the disabled people. In Dhaka city local buses don't have any wheelchair ramps. This paper is about the design of wheelchair ramp for local buses in Dhaka city.

## **1.2 Background**

Historically, step entrances in transit buses presented a barrier to boarding and disembarking for wheeled mobility users. Electromechanical lifts initially were used to address this accessibility barrier; however, lifts are considered unsatisfactory because they are prone to breakdown, require bus driver assistance, create long loading and unloading delay, and are not helpful for ambulation aid users. The emergence of low-floor bus designs in the late 1980s lowered the entry and exit height by 3–4 inches (Blennemann 1991), thus reducing physical demands and tripping risks (Schneider and Brechbuhl 1991; Rutenberg 1995). Many low-floor buses also “kneel” at stops, further.

Compared to wheelchair lifts, access ramps have a simpler design that is less prone to breakdown and requires less maintenance (Blennemann 1991; Schneider and Brechbuhl 1991; Rutenberg 1995). Ramps enable wheeled mobility users to board vehicles more discreetly and in less time (Blennemann 1991; Rutenberg 1995). For drivers, ramps are simpler to deploy and do not require them to leave their seat (Rutenberg 1995; Schneider and Brechbuhl 1991). Ramps can also be used by ambulation aid users, parents pushing strollers, and riders with rolling suitcases or shopping carts, allowing greater percentage of passengers to enter and exit the bus with reduced effort and assistance (Schneider and Brechbuhl 1991).

## **1.3 Previous Ramp Research**

The accessibility of ramps for buildings was first evaluated in the late 1970s (Steinfeld, Schroeder, and Bishop 1979), which led to the 1:12 slope standard now required for accessible buildings. For transit vehicles, an early study was contracted by the Urban Mass Transportation Administration (UMTA, now the Federal Transit Administration, FTA) (RRC International 1977), which reported findings based on an unspecified number of mobility aid users who evaluated ramp slopes ranging from 1:9 to 1:2. For wheelchair users, slopes of 1:3 could not be negotiated without assistance; unassisted entry was possible for some with slopes between 1:4 and 1:6; and ramp slopes shallower than 1:6 were substantially easier to traverse independently. Ambulation aid users found it very difficult to maintain standing balance at the 1:3 slope and thus necessitated assistance, slopes of 1:4 and 1:6 could be independently traversed with difficulty and often required assistance to exit the bus, and slopes of 1:6 and shallower could be traversed unassisted and without difficulty.

This was a groundbreaking study that, nonetheless, had three key limitations: the participant sample was vaguely described in terms of device used and functional ability, the measurement tools were not described, and the research design and procedure were not described in a manner that would support replicability. Since 1977, there have also been some significant advances in wheelchair seating and mobility technology, notably the introduction of midwheel-drive power chairs, seating and positioning systems that allow more severely-impaired individuals to travel independently, and wheelchair frames that accommodate larger and heavier people (Steinfeld et al. 2010).

Sweeney et al. (1989) evaluated 13 portable ramps ranging from 1:12 to 1:3 with 45 participants representing a diverse age range, wheeled mobility devices, and functional levels. The authors reported that ramp slopes of 1:12 to 1:7 could be negotiated with “relative ease” by 88% of the self-propelling manual wheelchair users (n=18), compared to 52% of the same group for the 1:6 slope. All seven power wheelchair users traversed the 1:12 to 1:7 slopes with relative ease, compared to 66% of the same group for the 1:6 slope. Nuanced interpretation of these findings is difficult because the measurement scales were not described for assessing ease of use, and the data were aggregated for slopes ranging from 1:12 to 1:7.

Blennemann (1991) evaluated ramp gradients from 1:16 to 1:5. The findings were based on “workshops” involving an unreported number of wheelchair users, their caregivers, and older adults. Manual wheelchair users navigated the 1:10 slope without difficulty, reported some difficulty with slopes between 1:10 and 1:6, and were unable to negotiate ramps of 1:5 without assistance. Power wheelchair users negotiated slopes as steep as 1:6 without difficulty; however they reported a fear of overturning at a slope of 1:5. Definitive interpretations of these data are not possible because the user groups were not well articulated, the data collection procedures were not described, and the measurement scales were not described.

Sanford, Story, and Jones (1996) evaluated the usability of 6 slopes ranging from 1:8 to 1:20 for 171 participants who used a range of mobility aids. The authors concluded that ramps steeper than 1:12 and longer than 30 feet are difficult to use by manual wheelchair users. Although these findings provide an excellent starting point, the data reflect an experimental ramp length (30') that is not directly comparable to the typical length (~6') of access ramps in transit vehicles.

It is difficult to derive conclusive slope guidelines from the above literature because key factors (e.g., ramp length, ramp slope, population studied, and measurement tools) are quite disparate and often vaguely described. In this paper the design of the wheelchair ramp is focused on these guidelines.

## 1.4 Scope of Project

The design of the wheelchair ramp is focused on

- ADA guidelines for accessible design
- Simple construction
- Easy installation

The fabrication of the wheelchair ramp is focused on

- Availability and cost of the material
- Installation Cost on public bus transportation in Dhaka city.
- Durability and Sustainability
- Maintenance

The design of the ramp is carried out after careful evaluation of different local buses around Dhaka city.

This design applies not only to people who use wheelchairs but also to those who have difficulty climbing stairs, such as people who have arthritis or hemiplegic and those who use walkers, crutches or canes.

## 1.5 Parameters Considered

### Ramp Slope

Slope is the term used to describe how steep a ramp is. The slope is extremely important because it affects how difficult it is to travel up and down the ramp. If the slope is too steep, the ramp may be too difficult for someone to use or may even be unsafe.

To determine the slope: divide rise by the run of ramp. Run is not the length of the ramp. The distance horizontally (not along the slope) from the top of the ramp to the bottom

### Ramp width

Ramp width depends on the width of the wheelchair and availability of the space

### Ramp elevation

The height a ramp can lift from the ramp landing

### Ramp length

The length of the ramp depends on the slope and the elevation of the ramp.

### Ramp landing/platform :



The landing of the ramp has to be on a platform having a minimum height of 30 inch.

#### ❑ Modification for Bus

After evaluation of different local buses around Dhaka city the following height of the bus floor and width of the door are found

- Average Height of the bus floor : 30- 36 inch
- Average Door Width: 24-30 inch.

So the modification for the installation of the ramp are

- Door width: minimum 39 inch of free space
- Introduction of folding seats ( in front row) to facilitate the wheelchair

## **1.6 Project Goals**

- Accessible design for safe and comfortable movement for person with physical disability.
- Economic fabrication of ramp
- Easy and cost efficient installation on public bus that has no accessibility.
- Durability and Sustainability

## **CHAPTER 2**

### **2.1 Methodology**

The 3D design of the wheelchair ramp was prepared using solid works simulation 2013. Accessible design was followed for the ramp design. Static Study was done for the Factor of safety (FoS), Stress and Displacement analysis. Four different materials (Balsa wood, Galvanized steel, Aluminum, Stainless steel) were used for the wheelchair ramp. The fabricated prototype of the ramp was done by using Plywood.

#### **2.1.1 Factor of Safety**

Factor of Safety refers to the actual load-bearing capacity of a structure or component and also the required margin of safety for a structure or component according to code, law, or design requirements. A FoS of 1 means that a structure or component will fail exactly when it reaches the design load, and cannot support any additional load. Structures or components with FoS < 1 are not viable; basically, 1 is the minimum. With the equation above, a FoS of 2 means that a component will fail at twice the design load, and so on.

#### **2.1.2 Stress Analysis**

Linear stress analysis is used to calculate the stresses and deformations of geometry having three basic assumptions: The part or assembly under load deforms with small rotations and displacements; the product loading is static (ignores inertia) and constant over time; the material has a constant stress strain relationship (Hooke's law).

For ductile material we have considered Von Mises stress analysis. Design will fail, if the maximum value of Von Mises stress induced in the material is more than strength of the material.

### **2.1.3 Displacement Analysis**

Displacement analysis shows how much displacement will occur when it is subjected to the specified load. High value of displacement will create discomfort for the person on the wheelchair.

## **2.2 Design Concept and Approach**

### **2.2.1 Accessible Design**

Accessible design is a design process in which the needs of people with disabilities are specifically considered. Accessibility sometimes refers to the characteristic that products, services, and facilities can be independently used by people with a variety of disabilities.

Accessibility as a design concern has a long history, but public awareness about accessibility increased with the passage of legislation such as the Americans with Disabilities Act (ADA)

The ADA is a civil rights law that prohibits discrimination against individuals with disabilities in all areas of public life, including jobs, schools, transportation, and all public and private places that are open to the general public.

### **2.2.2 ADA guideline**

- ADA Standards REQUIRE a 1:12 slope ratio which equals 4.8 degrees or one foot of
- Wheel chair ramp for each inch of rise. For instance, a 30 inch rise requires a 30 foot handicap wheelchair ramp.
- ADA Guidelines REQUIRE a Minimum 5' x 5' Flat, unobstructed area at the top and bottom of the ramp.
- ADA Standards REQUIRE wheelchair ramps to have a Minimum 36 inches of clear space across the wheelchair ramp.
- ADA Code REQUIRE a Minimum Turn Platform size of 5' x 5'.
- ADA Guidelines for Wheelchair Ramps allow a MAXIMUM run of 30 feet of wheelchair ramp before a rest or turn platform.
- ADA Ramp Guidelines REQUIRE handrails that are between 34" and 38" in height on both sides of the wheelchair ramps

### 2.2.3 Initial Design Consideration

Initial designing of the ramp was done after considering the following points

- Who's the primary user?
- What type of assistive device does the person use (cane, crutches, walker, manual or electric wheelchair, motorized 3-wheel cart)?
- Will the person use the ramp independently or will help be needed?
- Who will provide help and what are that person's abilities?
- Which entryway is best for the ramp?
- Placement of existing door handles and swing direction of doors.
- Where is the best place to access transportation?
- How will the ramp affect available space?
- How will the ramp appear?
- What will the installation cost be?

## 2.3 Dimension of the Ramp

### ❑ Ramp slope

Slope The accessibility of access ramps is affected by their slope, which is often described by a ratio,  $a:b$ , indicating a rise of  $a$  inches for every  $b$  inches in run. The Americans with Disabilities Act Accessibility Guidelines (ADAAG) for Transportation Vehicles stipulate that ramp slope may vary from 1:4 to 1:12, depending on the overall rise (U.S. Access Board and Department of Transportation 1998).

Table 1 Ramp slope

Slope (rise: run)	Gradient (%)	Angle (°)
1:2	50.0%	26.6
1:4	25.0%	14.0
1:6	16.7%	9.5
1:8	12.5%	7.1
1:10	10.0%	5.7
1:12	8.3%	4.8
1:14	7.1%	4.1
1:16	6.3%	3.6
1:18	5.6%	3.2
1:20	5.0%	2.9

1:12(ADA recommended)

Maximum 1:6 (Use with assisted)

Available local Bus Height in Bangladesh is around 30-36 inch, then -

- According to slope 1/12, ramp length will be 30-36ft
- According to slope 1/6) ramp length will be 15- 18 ft.

However it is not practical and feasible because a lot of space is required also weight and cost will be significantly increased. We can overcome the height problem by introducing platform with a height of 24-30 inch.

For a platform of 24 inch and bus height of 30-36 inch:

Slope of 6 inch rise: 1/12 (Recommended by ADA)

Slope of 12 inch rise: 1/6 (Maximum condition)

- Ramp Elevation: Recommended 6 inch, Maximum 12 inch
- Ramp Length: 72 inch
- Ramp Width: The width should be 32 inch for ramp & 39 inch for bus door.

## 2.4 Safety Features

Installation of safety features including handrails, guardrails or crutch stops.

- Handrails** should account for variables including a person's height, arm and hand strength, how the rails are used. The preferred material is wood. Metal piping is sometimes used, but may present a problem for exposed skin in the wintertime. It should be installed on bus stops ramp landing pedestrian.
- Guardrails** and edging called "crutch stops" or "bump boards" are also good safety factors that keep users from slipping off the side of a ramp or landing. Guardrails are mounted along the structure's perimeter, Crutch stops are curbing mounted on, or a few inches above, the surface of the structure's perimeter.

# CHAPTER 3

## 3.1 Initial Design Using SolidWorks

The initial design of the ramp and its parts were designed using solid works 2013. All the dimensions are in INCH. After studying a number of models the following design was chosen for the project. The design is suitable for simple construction and installation on local buses.

### 3.1.1 3D view of the parts and assembly:

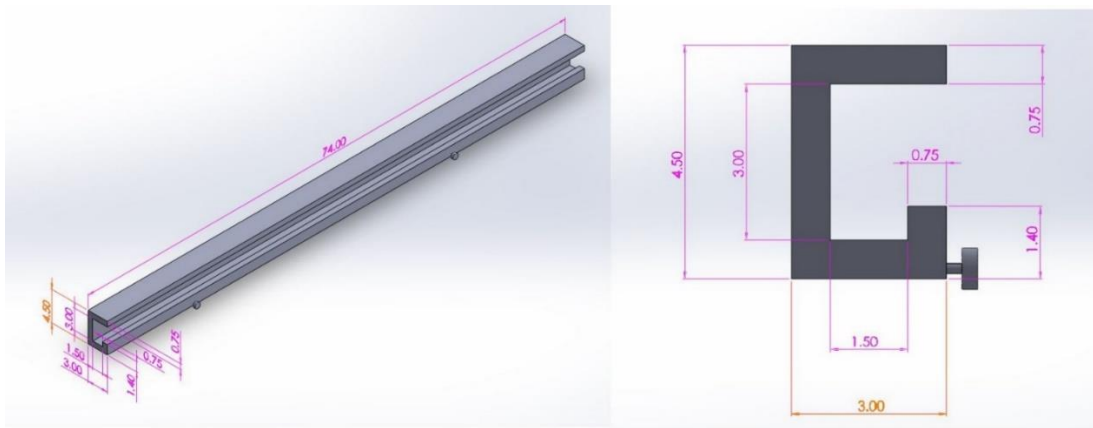

Figure 2 Channel 3D

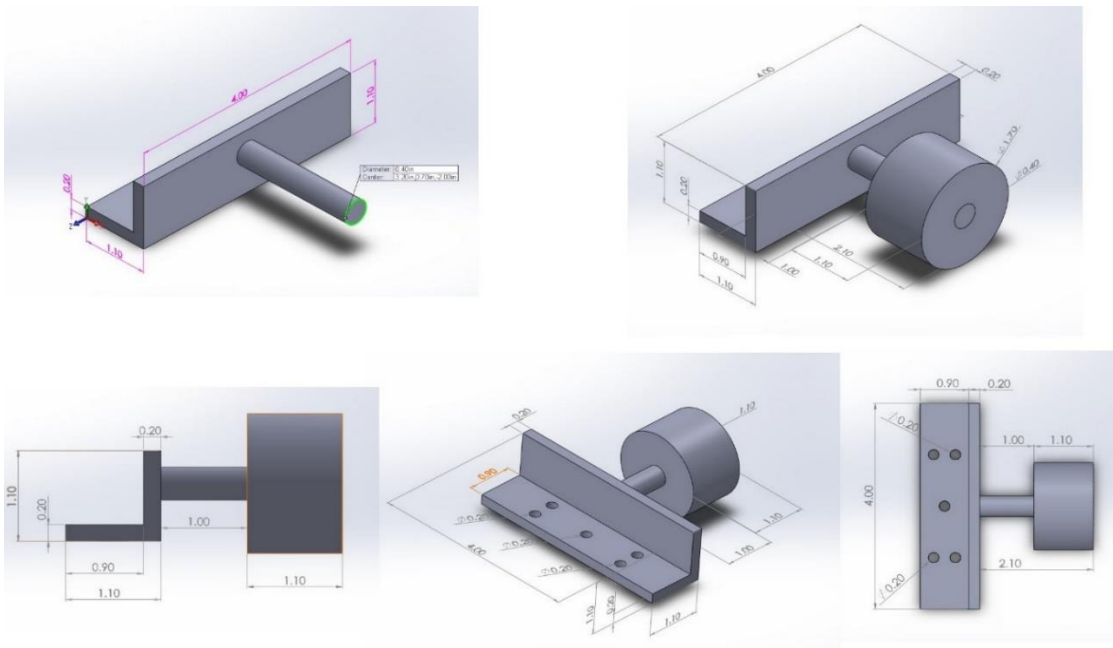

Figure 3 Slider hinge with wheel 3D

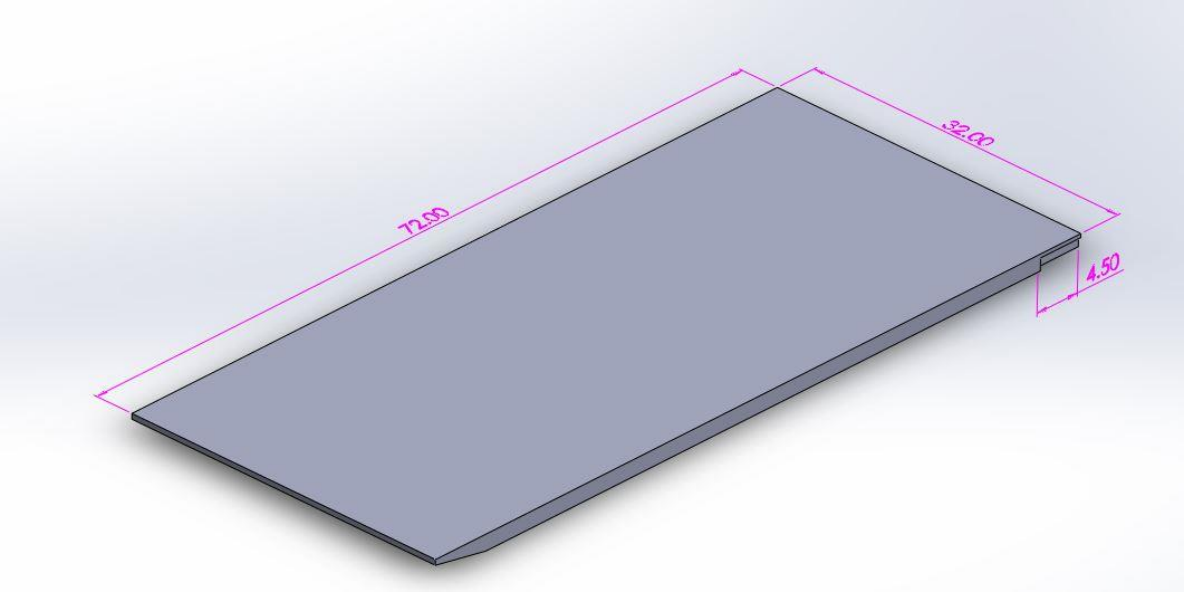

Figure 4 Ramp Body 3D

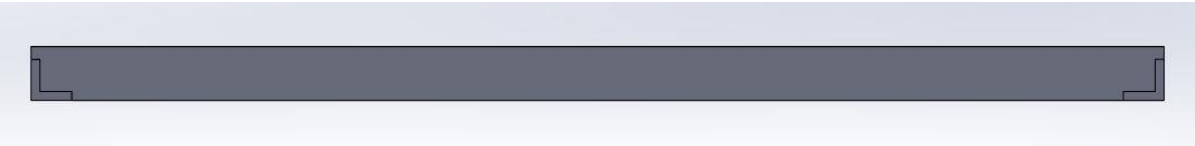

Figure 5 Ramp Body Back view

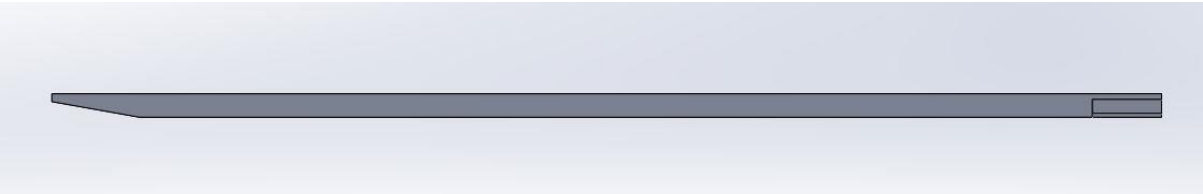

Figure 6 Ramp Body Side view

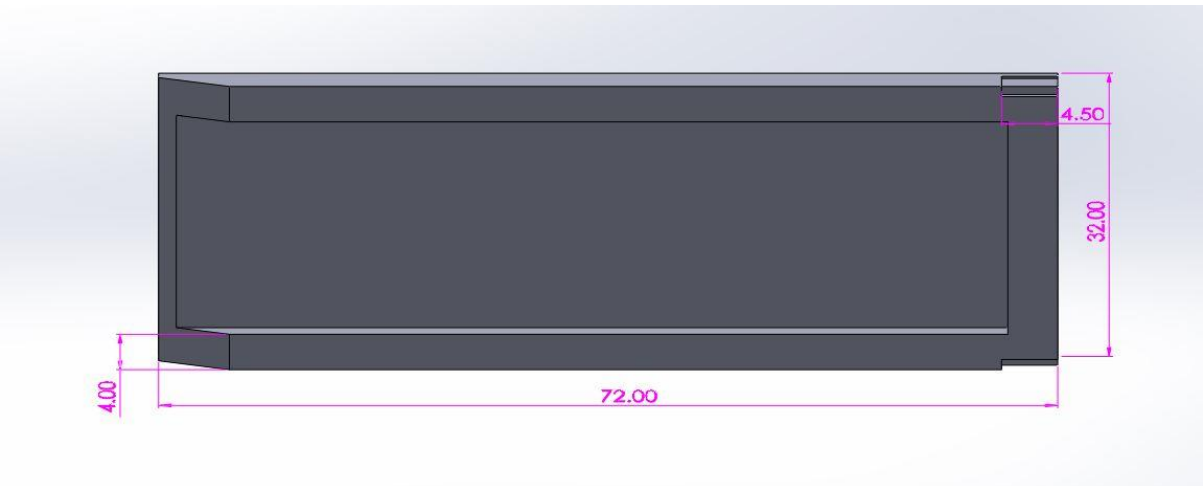

Figure 7 Ramp Body Bottom view 3D

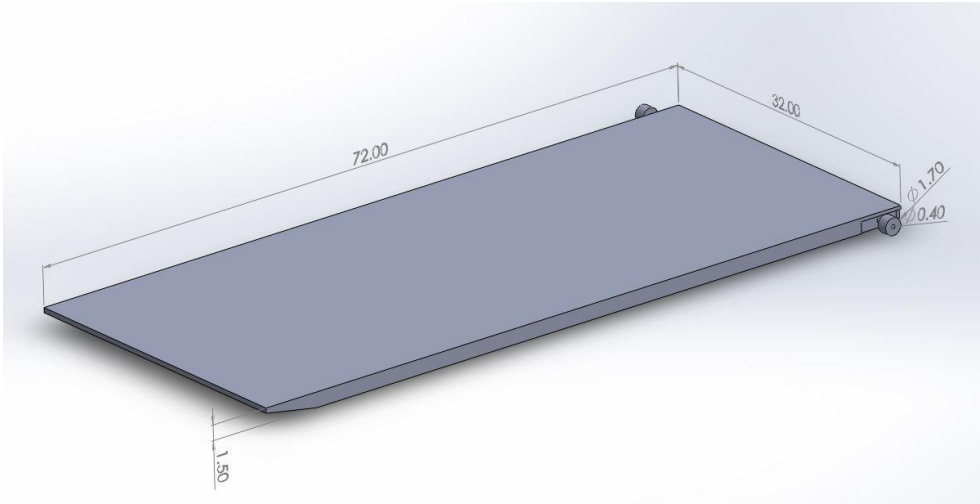

Figure 8 Ramp with Slider Wheel 3D

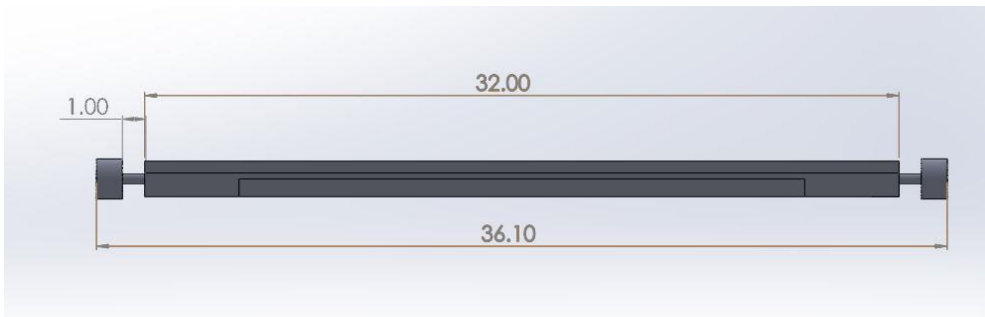

Figure 9 Ramp with Slider Wheel Back view 3D



Figure 10 Ramp with Slider Wheel Bottom view 3D



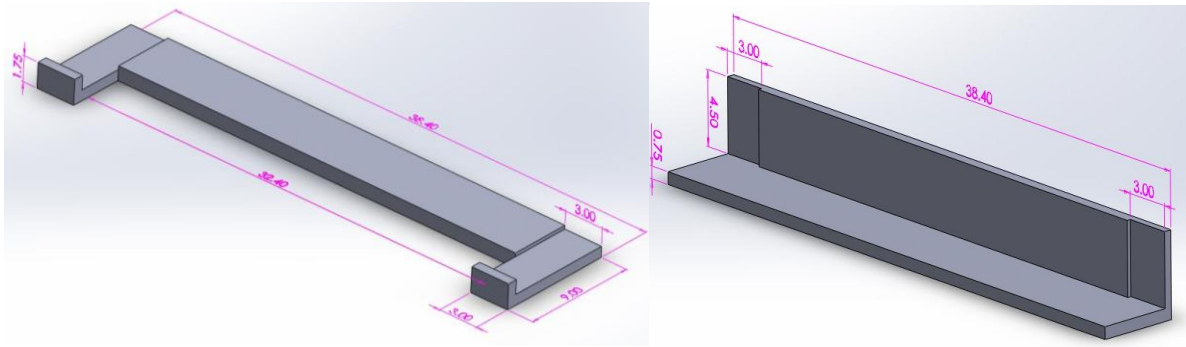

Figure 11 Front and Back Support for the assembly 3D

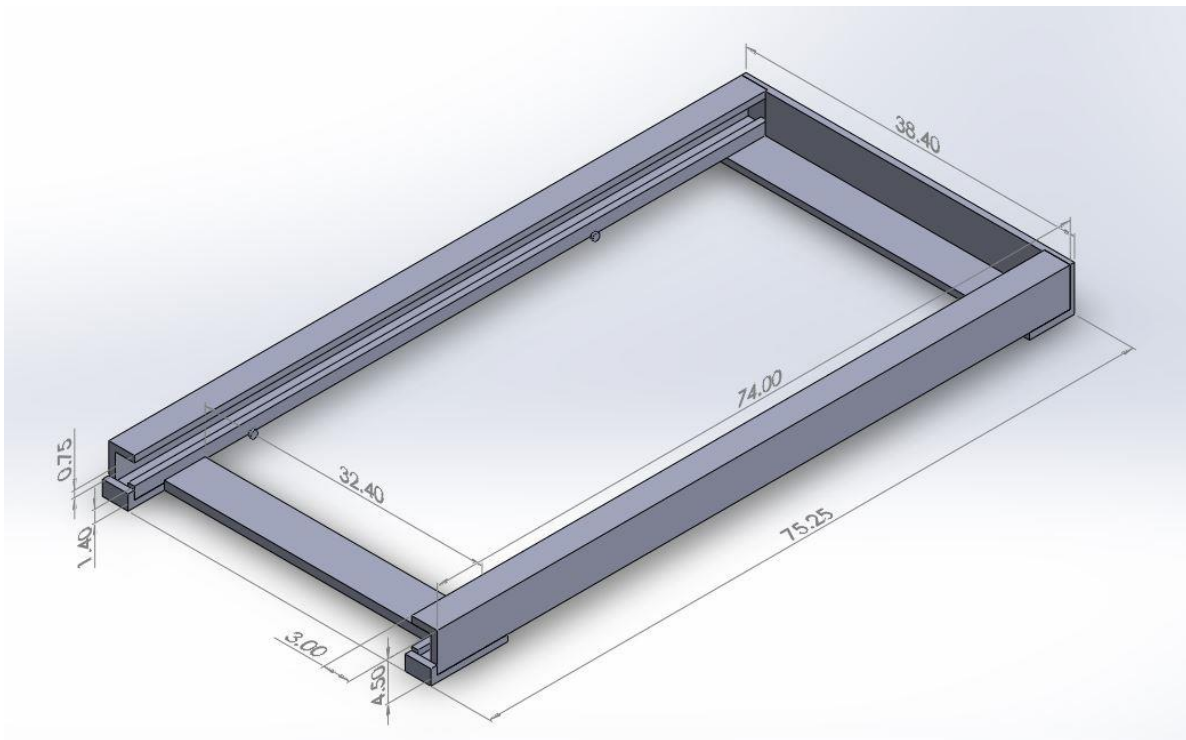

Figure 12 Channel Assembly 3D

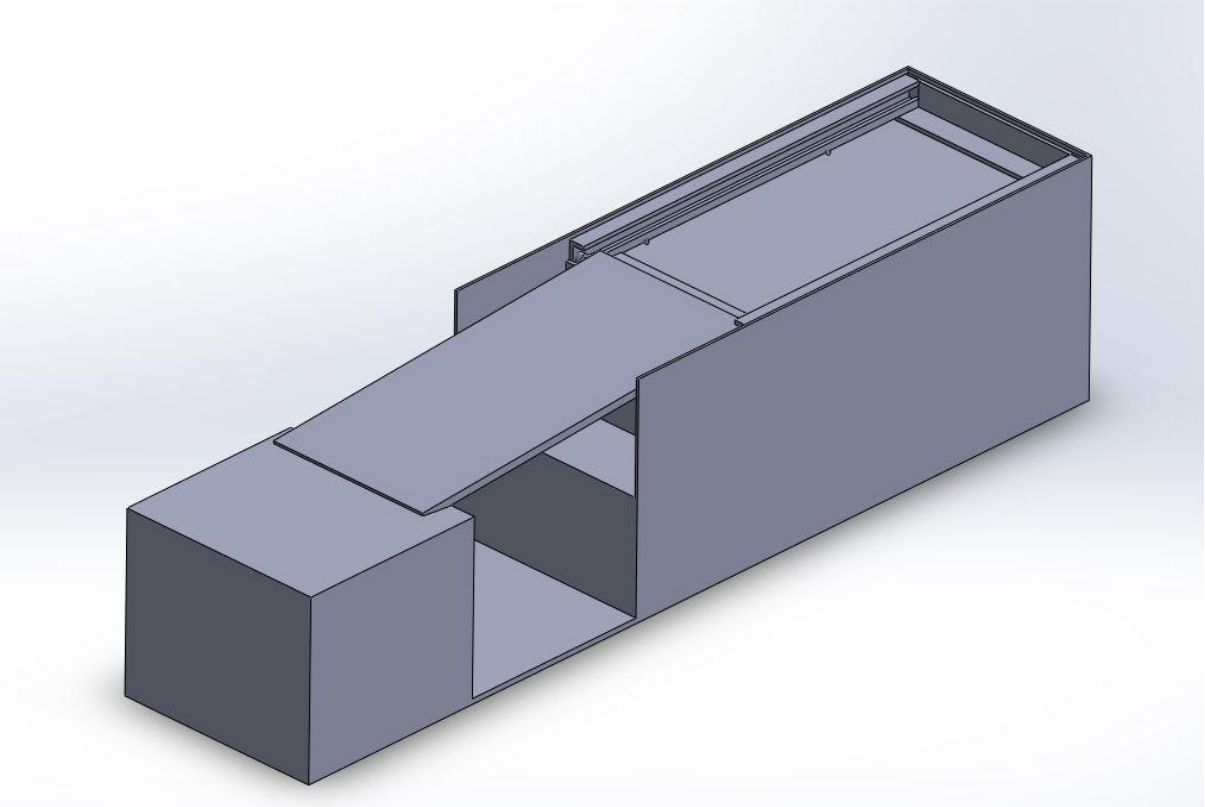

Figure 13 Ramp-Channel Assembly Installed on Stairs and Pedestrian 3D

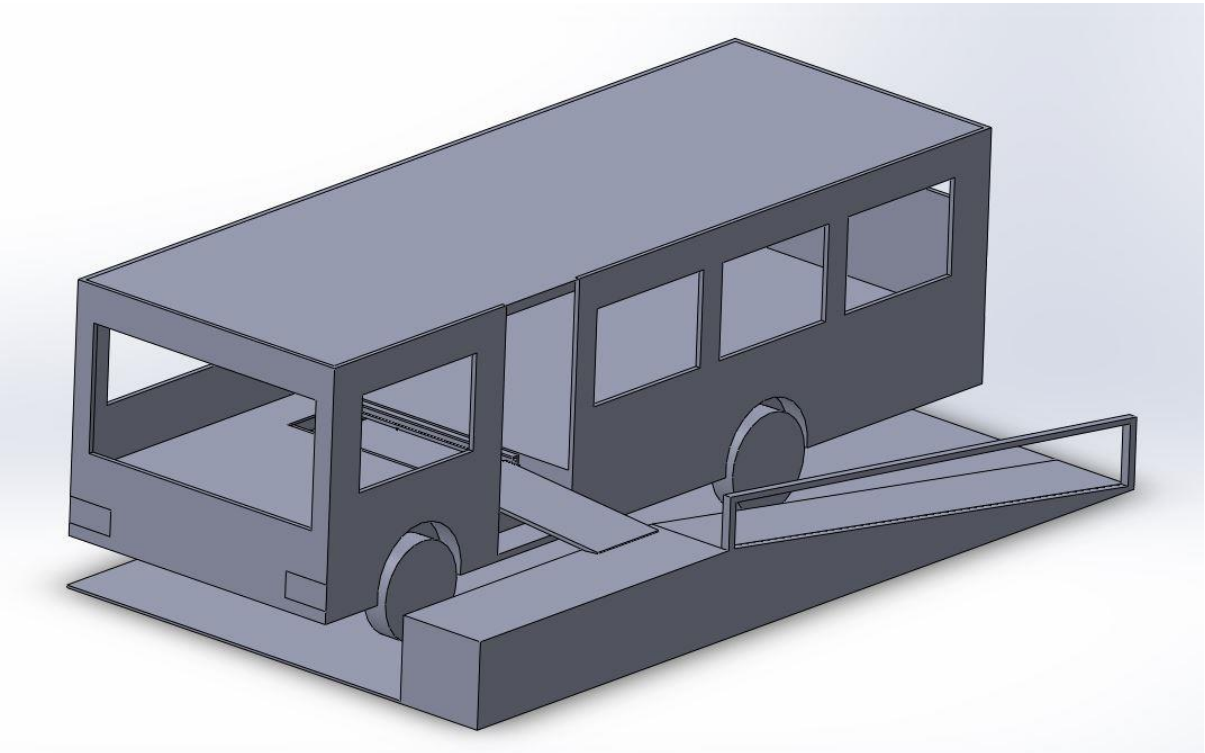

Figure 14 Ramp-Channel Assembly Installed on Bus 3D

### 3.1.2 Drawing of the parts

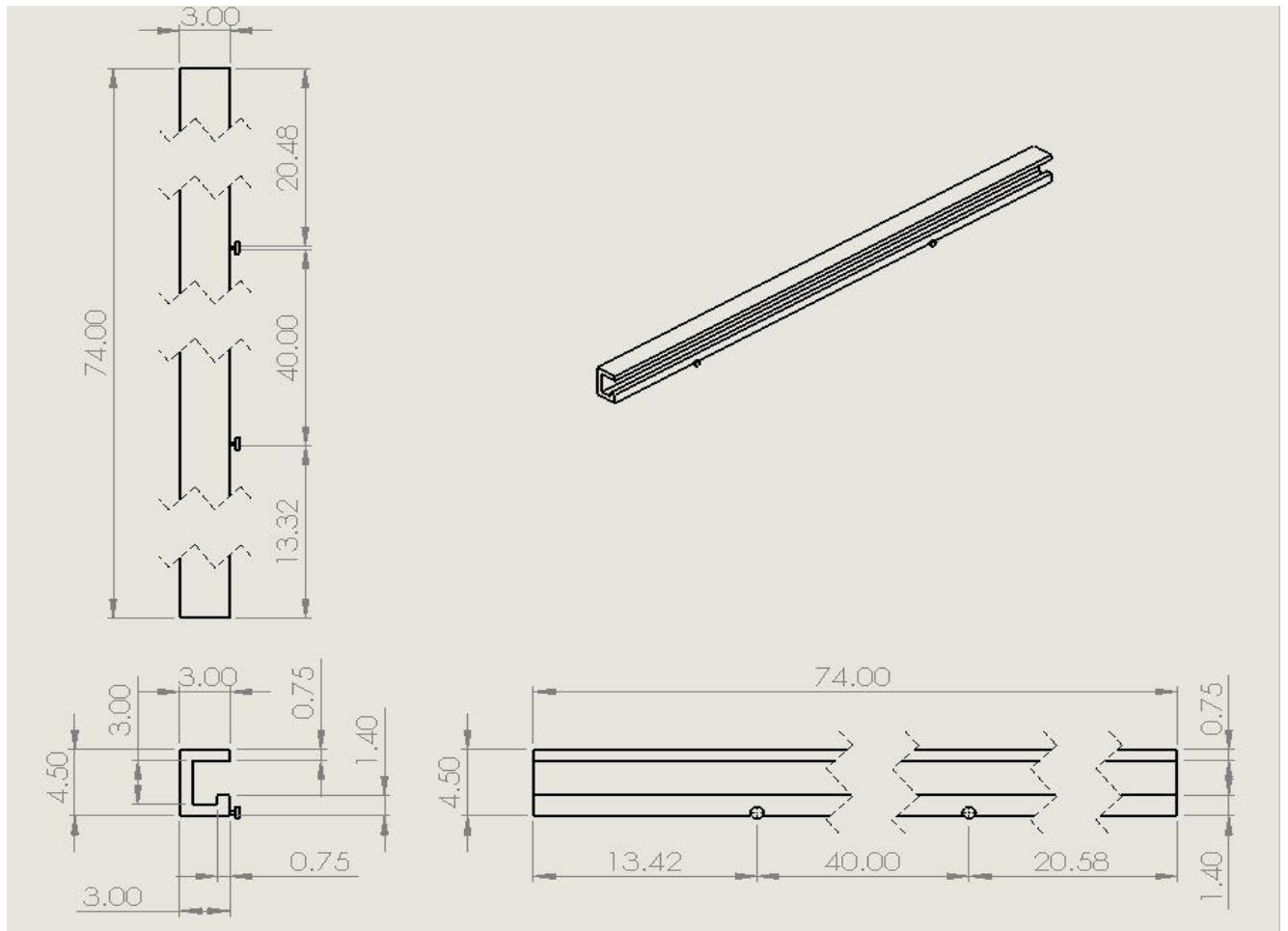

Figure 15 Channel Drawing

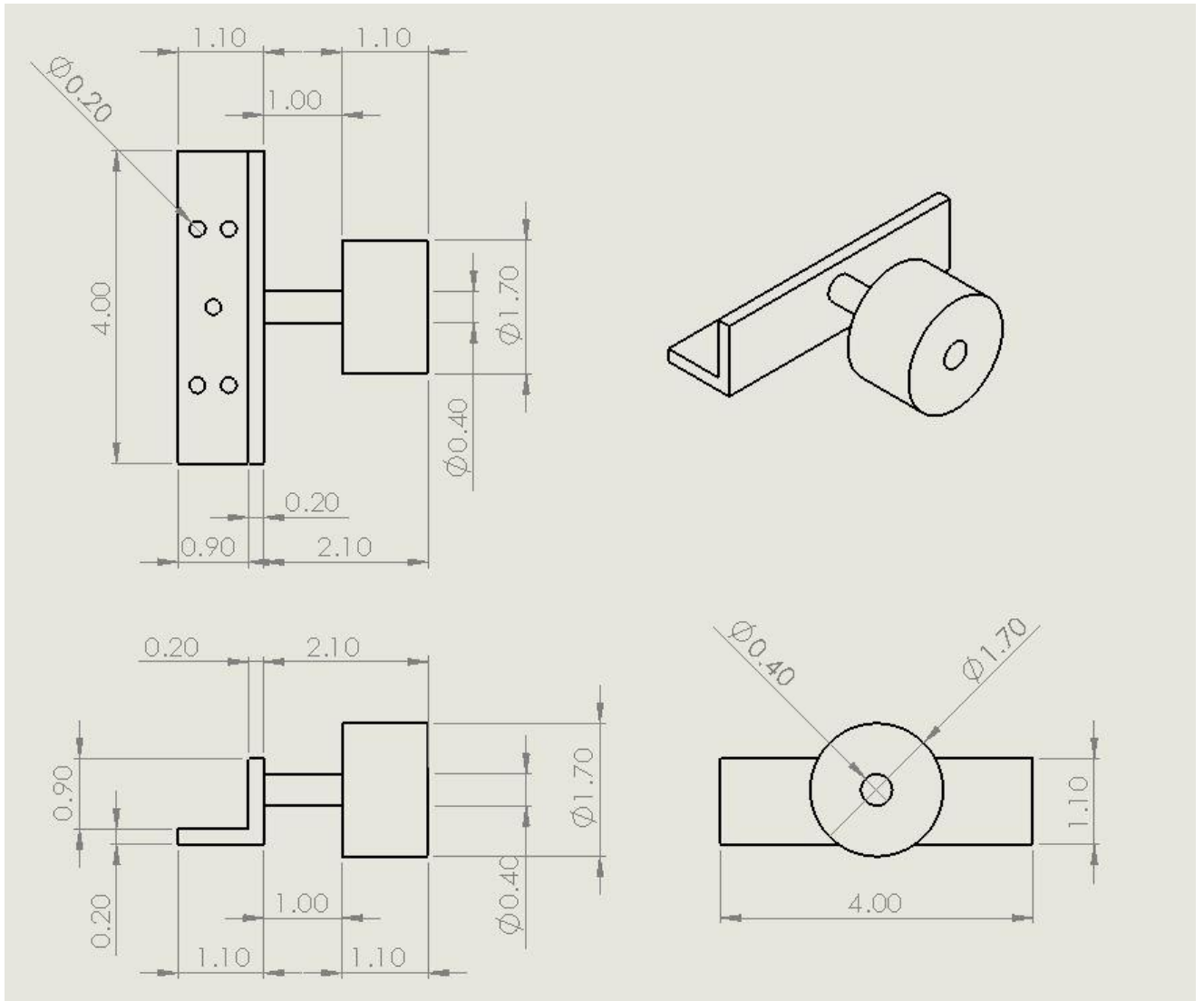

Figure 16 Slider hinge with wheel Drawing

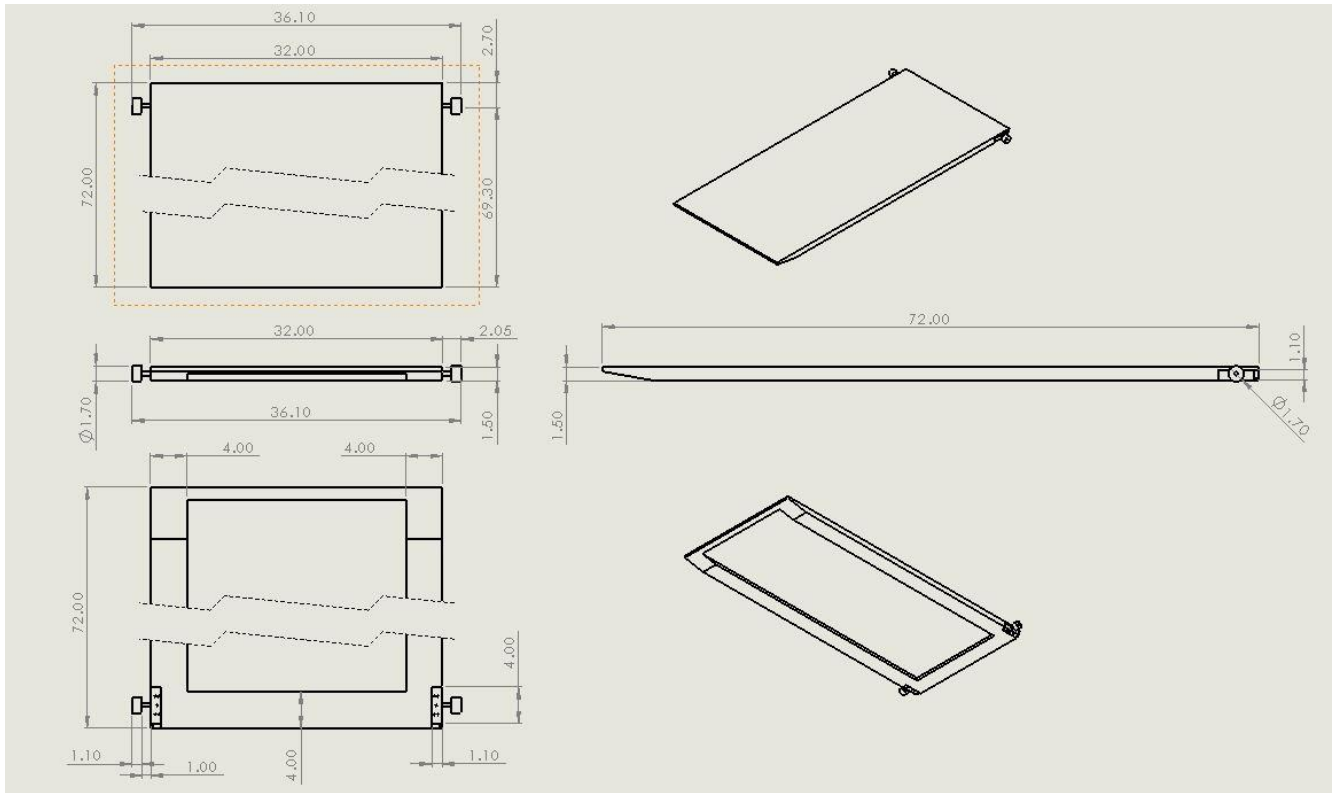

Figure 17 Ramp Board Drawing

## CHAPTER 4

### 4.1 Design Study based on SolidWorks Simulation

The design study was done in solid works simulation 2013. Static Study was done for finding the Maximum Stress, Maximum Displacement and Factor of Safety of the ramp body.

#### 4.1.1 Design Study for the following materials

Four Different materials are selected for the analysis. These materials are selected because of their availability and they are widely used as ramp material.

- Aluminum (1060 alloy)
- Galvanized Steel
- Stainless Steel (SS)
- Balsa (wood)

#### 4.1.2 Loads

For the analysis purpose five fixed points are selected. This points are estimated based on the position of the wheels of the wheelchair and the person assisting in driving the wheelchair. Normal loads are applied on this five fixed points.

- Total force : 1373.14N (140 kg for 2 persons and 1 wheelchair)
- Average Human weight : 65 kg per person
- Standard wheelchair weight: 10 kg

### 4.1.3 Loads and Fixtures

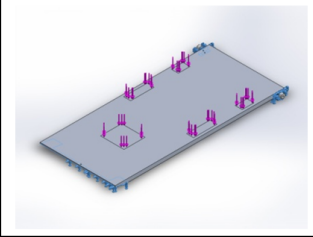
Fixture name	Fixture Image	Fixture Details				
Fixed-1		<table border="1"> <tr> <td>Entities:</td> <td>5 face(s)</td> </tr> <tr> <td>Type:</td> <td>Fixed Geometry</td> </tr> </table>	Entities:	5 face(s)	Type:	Fixed Geometry
Entities:	5 face(s)					
Type:	Fixed Geometry					
<b>Resultant Forces</b>						
Components	X	Y	Z	Resultant		
Reaction force(N)	-2.49172	1373.14	-0.806019	1373.14		
Reaction Moment(N·m)	0	0	0	0		

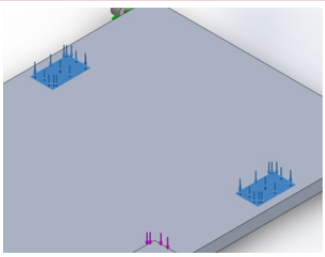
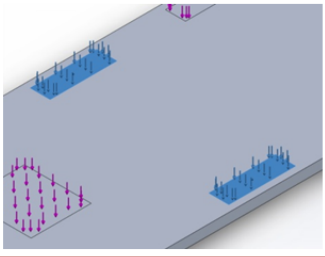
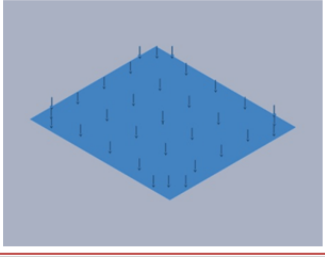
Load name	Load Image	Load Details						
Force-1		<table border="1"> <tr> <td>Entities:</td> <td>2 face(s)</td> </tr> <tr> <td>Type:</td> <td>Apply normal force</td> </tr> <tr> <td>Value:</td> <td>147 N</td> </tr> </table>	Entities:	2 face(s)	Type:	Apply normal force	Value:	147 N
Entities:	2 face(s)							
Type:	Apply normal force							
Value:	147 N							
Force-2		<table border="1"> <tr> <td>Entities:</td> <td>2 face(s)</td> </tr> <tr> <td>Type:</td> <td>Apply normal force</td> </tr> <tr> <td>Value:</td> <td>245 N</td> </tr> </table>	Entities:	2 face(s)	Type:	Apply normal force	Value:	245 N
Entities:	2 face(s)							
Type:	Apply normal force							
Value:	245 N							
Force-3		<table border="1"> <tr> <td>Entities:</td> <td>1 face(s)</td> </tr> <tr> <td>Type:</td> <td>Apply normal force</td> </tr> <tr> <td>Value:</td> <td>588 N</td> </tr> </table>	Entities:	1 face(s)	Type:	Apply normal force	Value:	588 N
Entities:	1 face(s)							
Type:	Apply normal force							
Value:	588 N							

#### 4.1.4 Fixed Geometry

For analysis, both slider hinges and the face which will be at contact with the landing surface are considered to be simply supported. The movement in any direction of the ramp due to the normal forces is restricted.

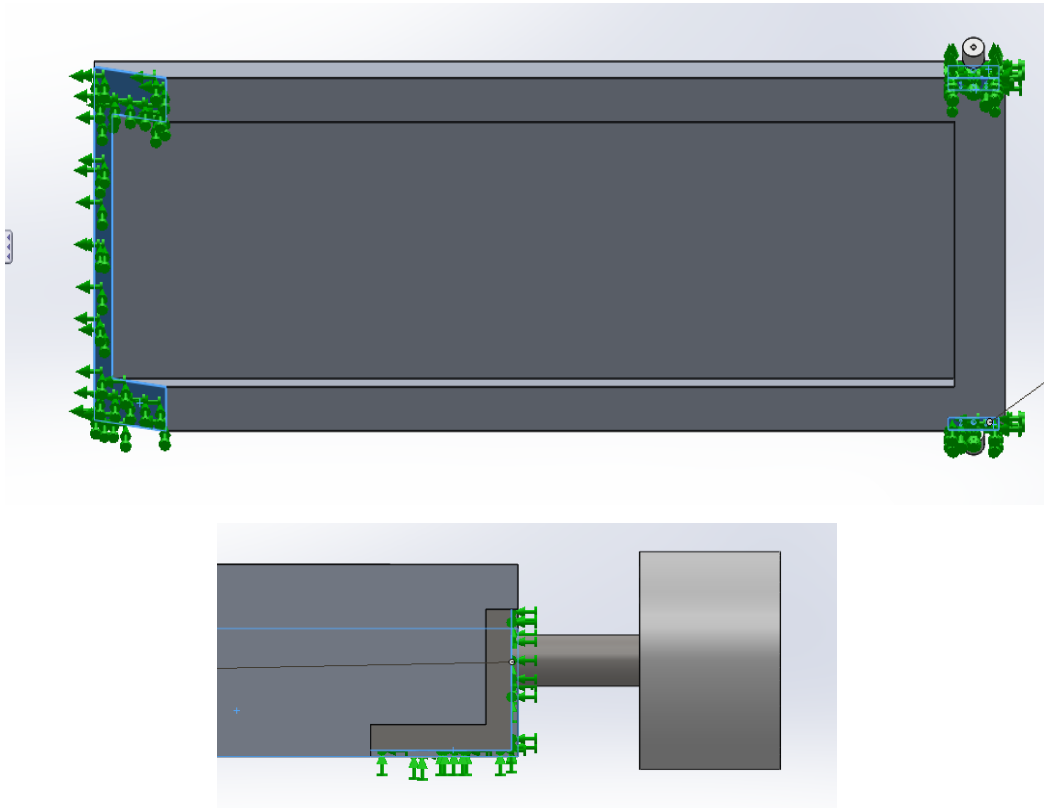

#### 4.1.5 Meshing

Meshing is the process to fill the model with nodes and elements i.e. to create a FEA model . Unit cell size of a mesh is very important. The element size of the mesh helps to determine the accuracy of the result. For our analysis purpose fine mesh density is used. The number of nodes increases, this provides an acceptable accuracy of result consuming a moderate amount of computational time.



# CHAPTER 5

## Results

### 5.1 Design Study 01

Material: Aluminum (1060 alloy)

#### 5.1.1 Model Information

Table 2 DS 1 Model Information

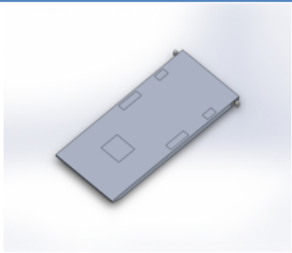
Figure	Treated As	Volumetric Properties
	Solid Body	<p>Mass: 97.359 kg            Volume: 0.0360589 m<sup>3</sup>            Density: 2700 kg/m<sup>3</sup>            Weight: 954.118 N</p>

#### 5.1.2 Material Properties

Table 3 DS 1 Material Properties

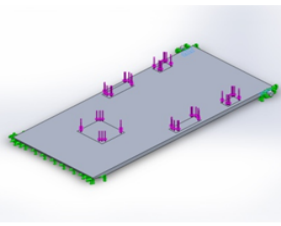
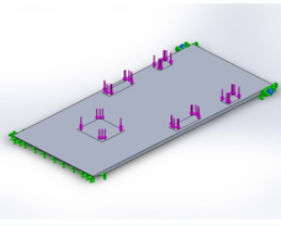
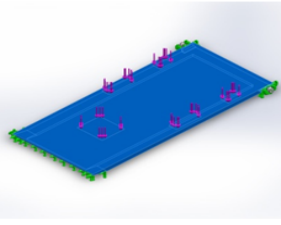
Model Reference	Properties	Components
	<p>Name: Cast Alloy Steel            Model type: Linear Elastic Isotropic            Yield strength: 2.41275e+008 N/m<sup>2</sup>            Tensile strength: 4.48082e+008 N/m<sup>2</sup>            Elastic modulus: 1.9e+011 N/m<sup>2</sup>            Poisson's ratio: 0.26            Mass density: 7300 kg/m<sup>3</sup>            Shear modulus: 7.8e+010 N/m<sup>2</sup>            Thermal expansion coefficient: 1.5e-005 /Kelvin</p>	Slider hinge
	<p>Name: ABS            Model type: Linear Elastic Isotropic            Tensile strength: 3e+007 N/m<sup>2</sup>            Elastic modulus: 2e+009 N/m<sup>2</sup>            Poisson's ratio: 0.394            Mass density: 1020 kg/m<sup>3</sup>            Shear modulus: 3.189e+008 N/m<sup>2</sup></p>	Slider Wheel
	<p>Name: 1060 Alloy            Model type: Linear Elastic Isotropic            Yield strength: 2.75742e+007 N/m<sup>2</sup>            Tensile strength: 6.89356e+007 N/m<sup>2</sup>            Elastic modulus: 6.9e+010 N/m<sup>2</sup>            Poisson's ratio: 0.33            Mass density: 2700 kg/m<sup>3</sup>            Shear modulus: 2.7e+010 N/m<sup>2</sup>            Thermal expansion coefficient: 2.4e-005 /Kelvin</p>	Ramp

### 5.1.3 Study Results (Stress)

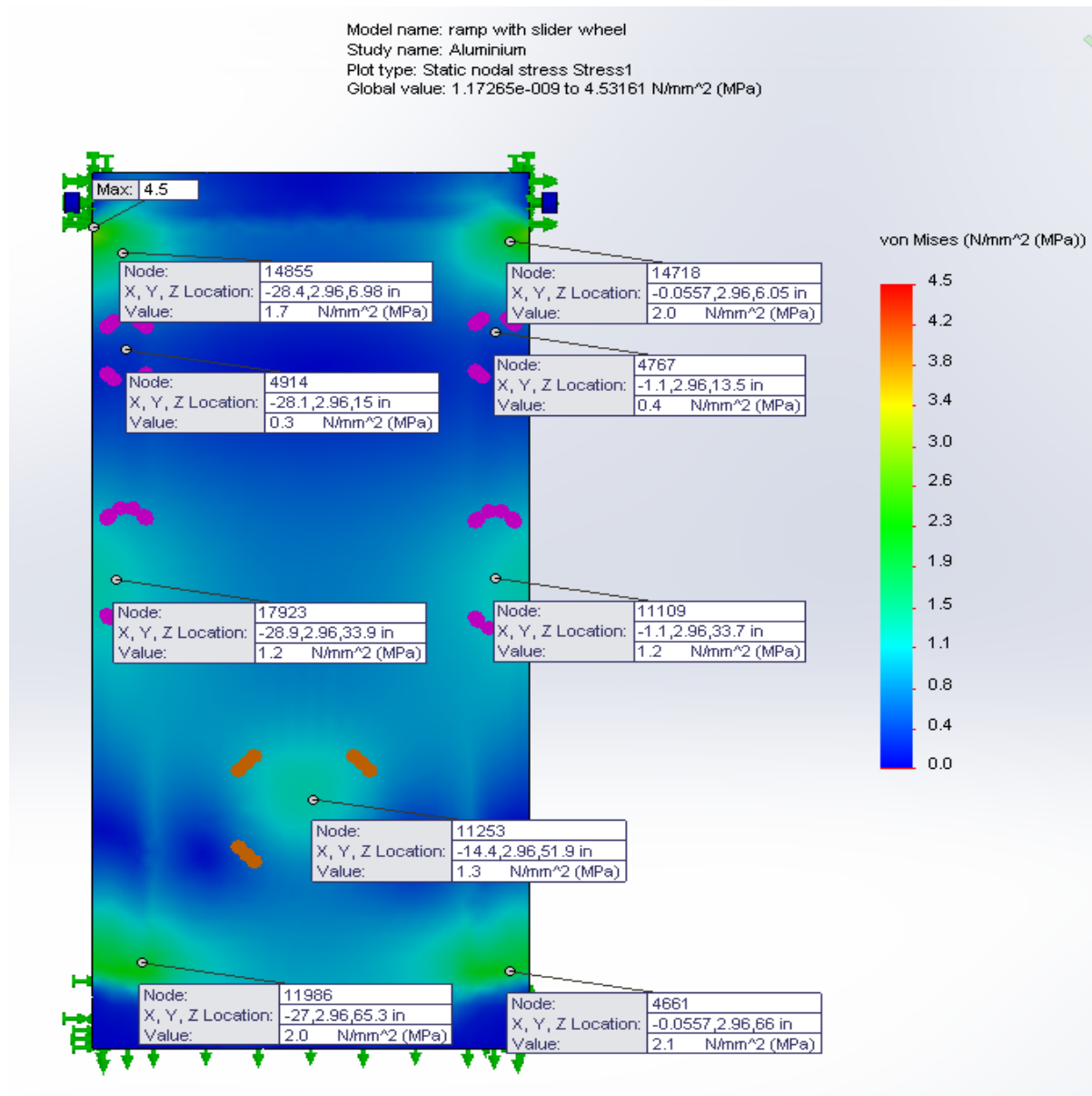

Figure 18 DS 1 Stress analysis

Table 4 DS 1 Stress analysis

Name	Yield Strength	Type	Min	Max
Stress	27.57 (MPa)	VON: von Mises Stress	1.17265e-009 (MPa)	4.53161 (MPa)

### 5.1.4 Study Results (FOS)

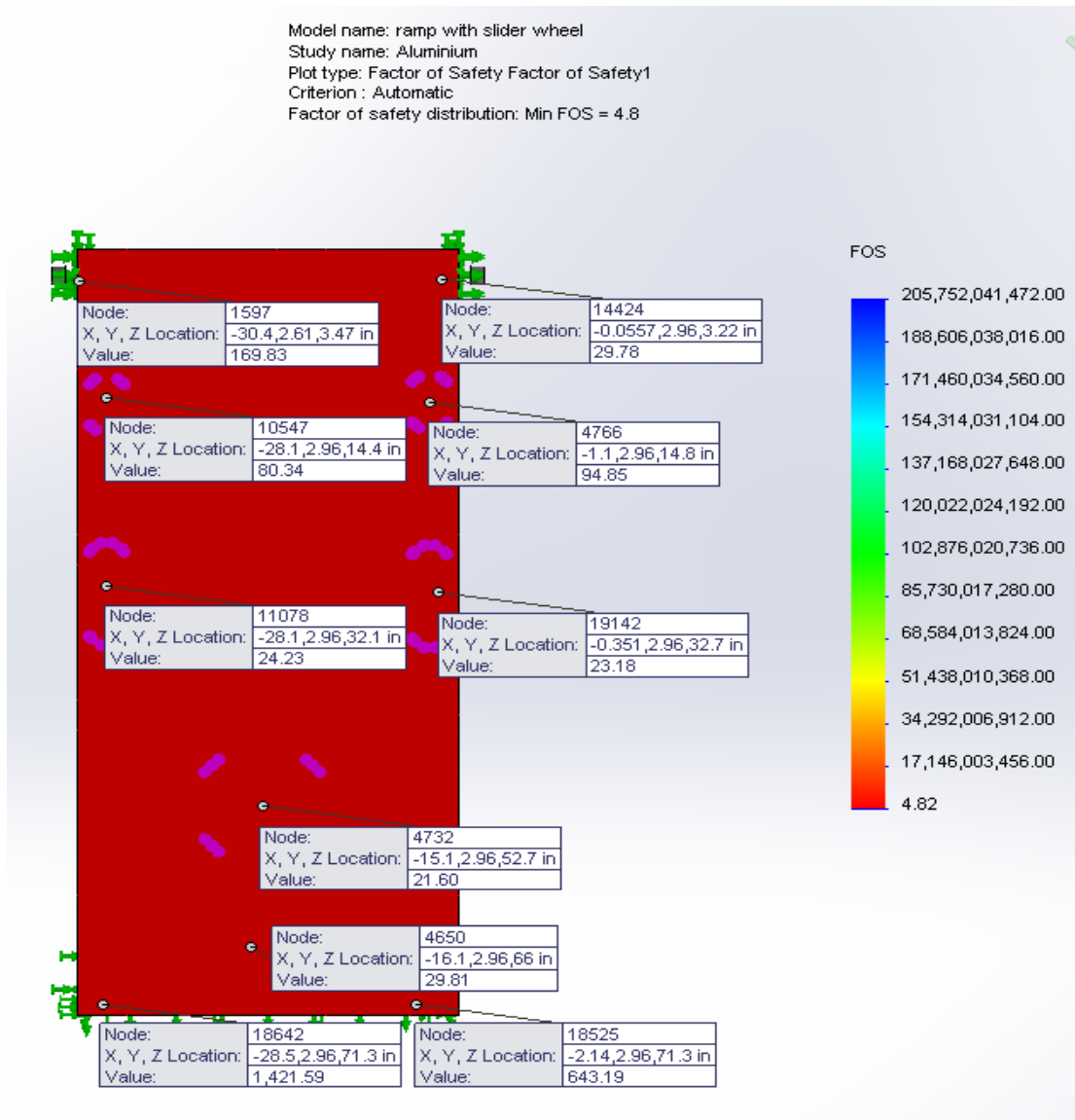

Figure 19 DS1 FoS analysis

Table 5 DS 1 FoS analysis

Name	Min	Max
Factor of Safety	4.82247	2.05752e+011

### 5.1.5 Study Results (Displacement)

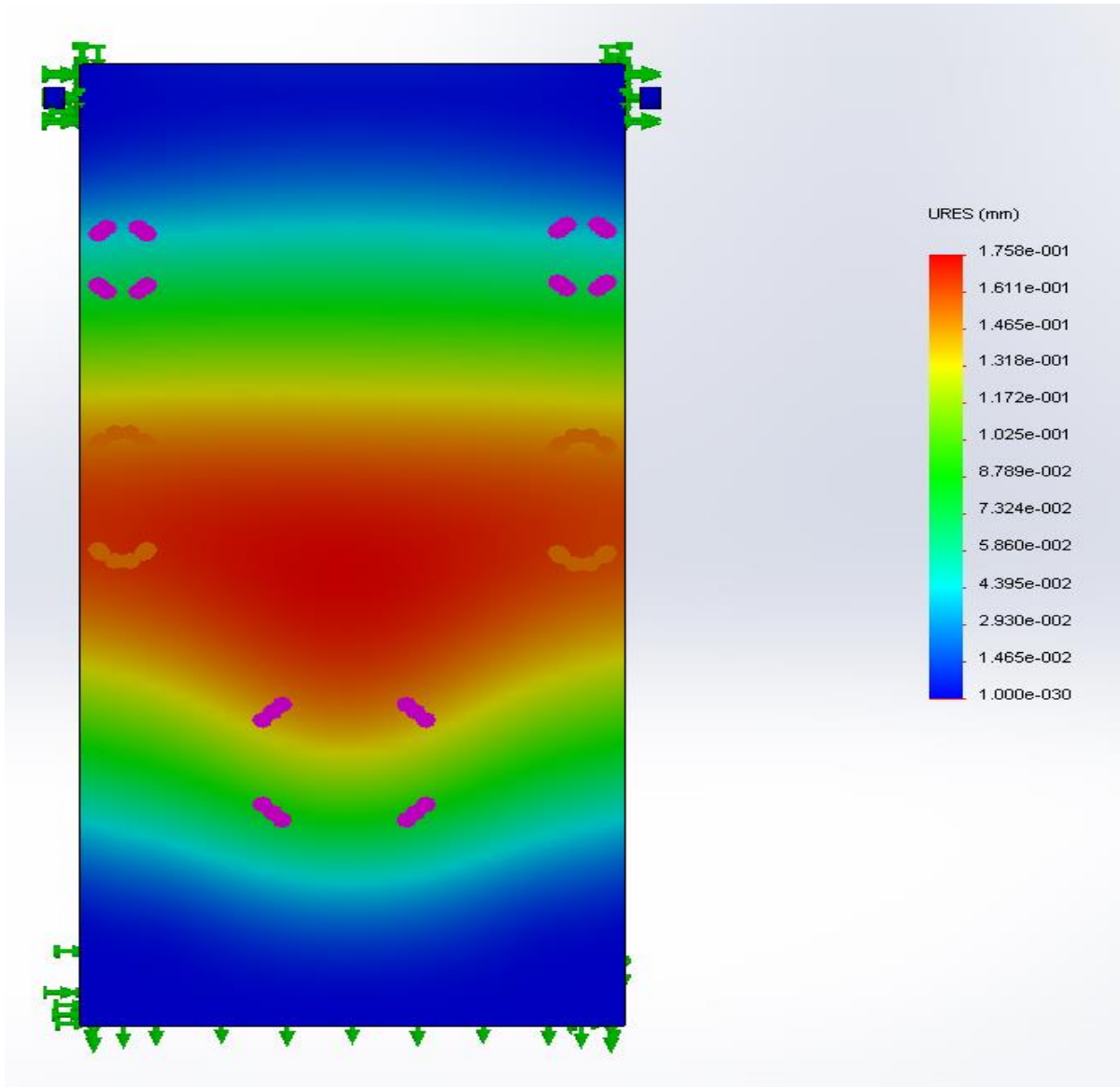

Figure 20 DS 1 Displacement analysis

Table 6 DS 1 Displacement analysis

Name	Type	Min	Max
Displacement	URES: Resultant Displacement	0 mm	0.175785 mm

## 5.2 Design Study 02

Material: Galvanized Steel

### 5.2.1 Model Information

Table 7 DS 2 Model Information

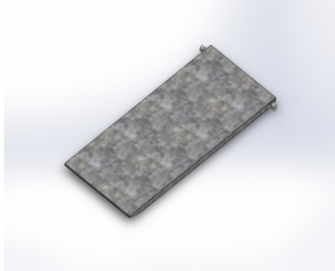
Figure	Treated As	Volumetric Properties
	Solid Body	<p>Mass: 283.784 kg            Volume: 0.0360589 m<sup>3</sup>            Density: 7870 kg/m<sup>3</sup>            Weight: 2781.08 N</p>

### 5.2.2 Material Properties

Table 8 DS 2 Material Properties

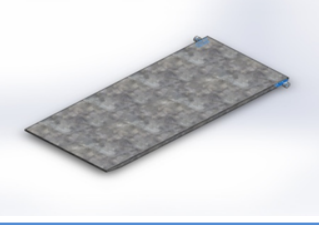
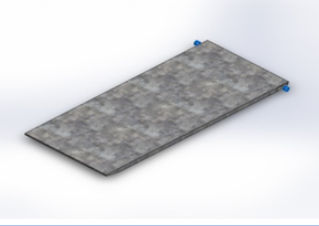
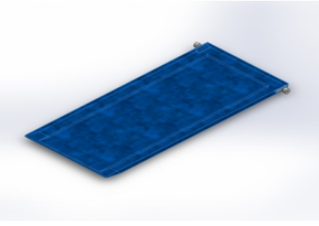
Model Reference	Properties	Components
	<p>Name: Cast Alloy Steel            Model type: Linear Elastic Isotropic            Yield strength: 2.41275e+008 N/m<sup>2</sup>            Tensile strength: 4.48082e+008 N/m<sup>2</sup>            Elastic modulus: 1.9e+011 N/m<sup>2</sup>            Poisson's ratio: 0.26            Mass density: 7300 kg/m<sup>3</sup>            Shear modulus: 7.8e+010 N/m<sup>2</sup>            Thermal expansion coefficient: 1.5e-005 /Kelvin</p>	Slider hinge
	<p>Name: ABS            Model type: Linear Elastic Isotropic            Tensile strength: 3e+007 N/m<sup>2</sup>            Elastic modulus: 2e+009 N/m<sup>2</sup>            Poisson's ratio: 0.394            Mass density: 1020 kg/m<sup>3</sup>            Shear modulus: 3.189e+008 N/m<sup>2</sup></p>	Slider Wheel
	<p>Name: Galvanized Steel            Model type: Linear Elastic Isotropic            Yield strength: 2.03943e+008 N/m<sup>2</sup>            Tensile strength: 3.56901e+008 N/m<sup>2</sup>            Elastic modulus: 2e+011 N/m<sup>2</sup>            Poisson's ratio: 0.29            Mass density: 7870 kg/m<sup>3</sup></p>	Ramp

### 5.2.3 Study Results (Stress)

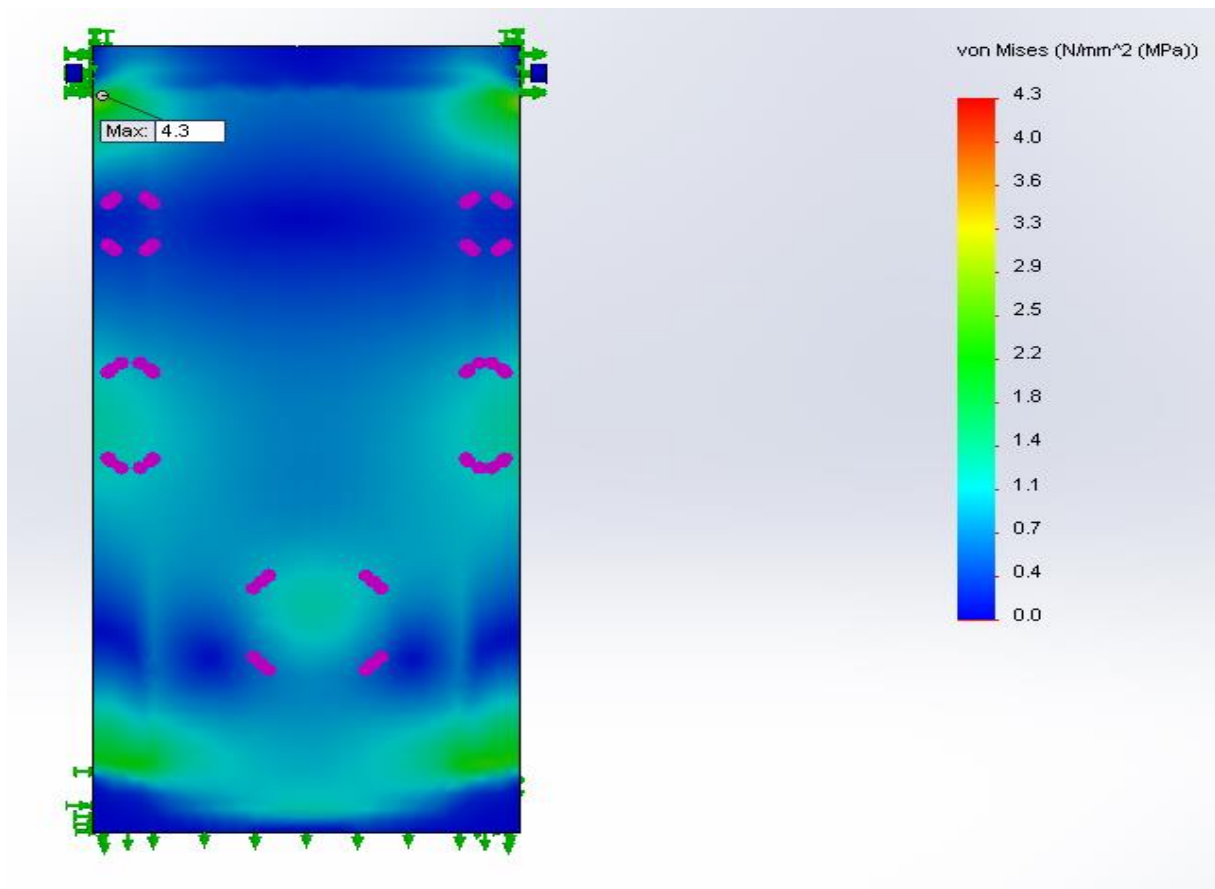

Figure 21 DS 2 Stress analysis

Table 9 DS 2 Stress analysis

Name	Yield Strength	Type	Min	Max
Stress	203.94 (MPa)	VON: von Mises Stress	1.25844e-009 (MPa)	4.34888 (MPa)

## 5.2.4 Study Results (FoS)

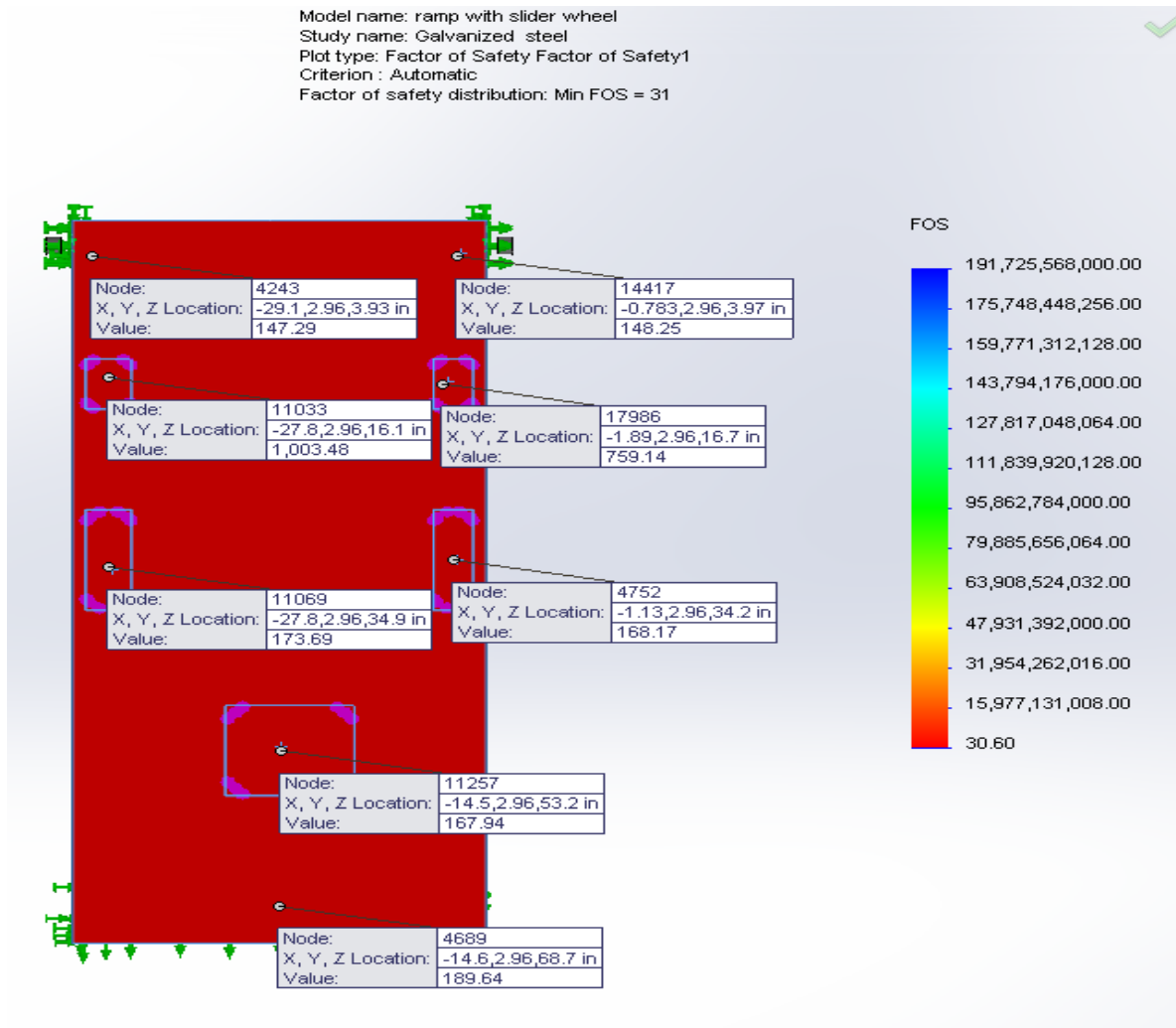

Figure 22 DS 2 FoS analysis

Table 10 DS 2 FoS analysis

Name	Min
Factor of Safety	31

## 5.2.5 Study Results (Displacement)

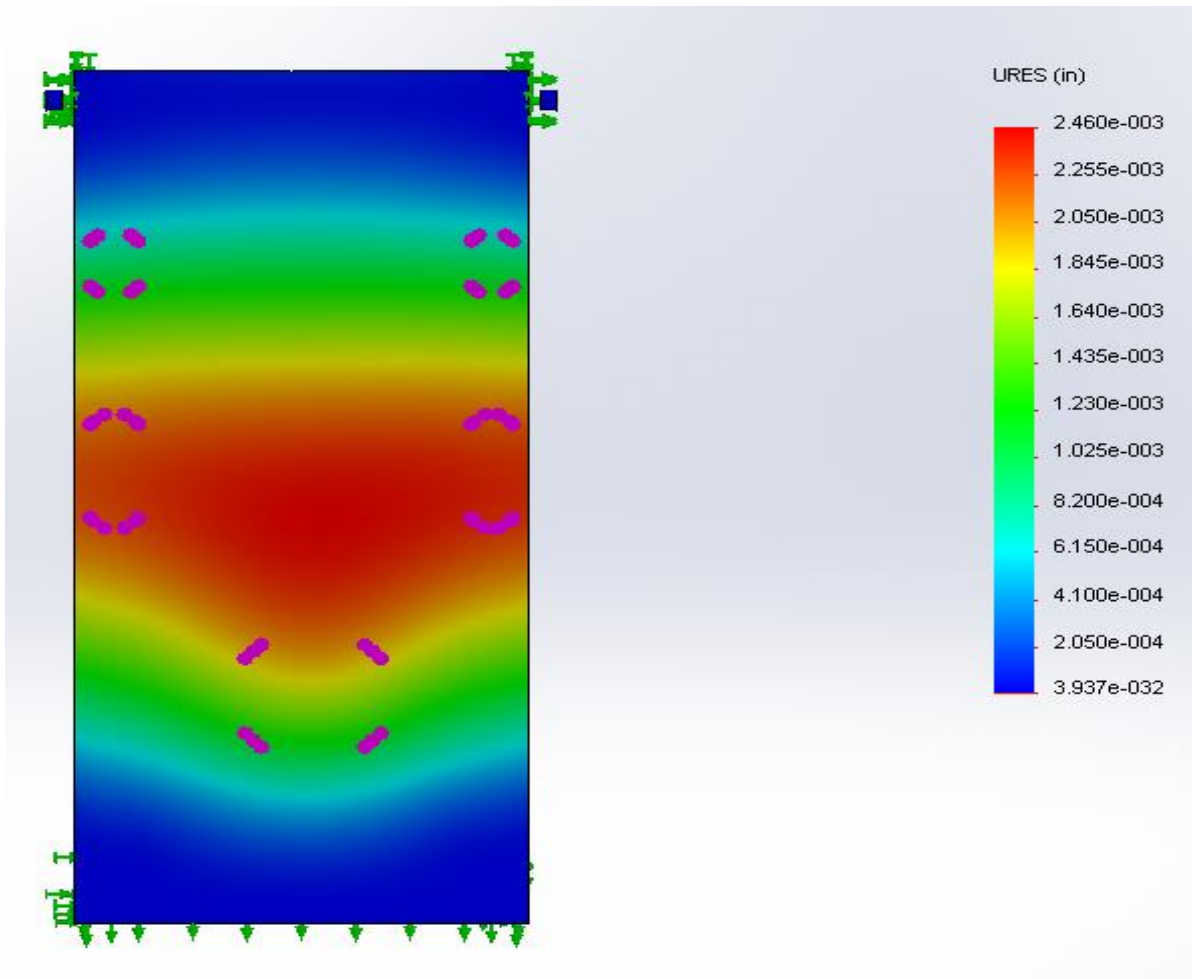

Figure 23 DS 2 Displacement analysis

Table 11 DS 2 Displacement analysis

Name	Type	Min	Max
Displacement	URES: Resultant Displacement	0 mm	0.062484mm



## 5.3 Design Study 03

Material Stainless Steel (SS)

### 5.3.1 Model Information

Table 12 DS 3 Model Information

Figure	Treated As	Volumetric Properties
	Solid Body	<p>Mass:288.471 kg            Volume:0.0360589 m<sup>3</sup>            Density:8000 kg/m<sup>3</sup>            Weight:2827.02 N</p>

### 5.3.2 Material Properties

Table 13 DS 3 Material Properties

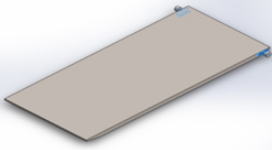
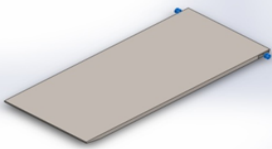
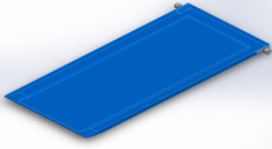
Model Reference	Properties	Components
	<p>Name: Cast Alloy Steel            Model type: Linear Elastic Isotropic            Yield strength: 2.41275e+008 N/m<sup>2</sup>            Tensile strength: 4.48082e+008 N/m<sup>2</sup>            Elastic modulus: 1.9e+011 N/m<sup>2</sup>            Poisson's ratio: 0.26            Mass density: 7300 kg/m<sup>3</sup>            Shear modulus: 7.8e+010 N/m<sup>2</sup>            Thermal expansion coefficient: 1.5e-005 /Kelvin</p>	Slider hinge
	<p>Name: ABS            Model type: Linear Elastic Isotropic            Tensile strength: 3e+007 N/m<sup>2</sup>            Elastic modulus: 2e+009 N/m<sup>2</sup>            Poisson's ratio: 0.394            Mass density: 1020 kg/m<sup>3</sup>            Shear modulus: 3.189e+008 N/m<sup>2</sup></p>	Slider Wheel
	<p>Name: AISI 316 Stainless Steel Sheet (SS)            Model type: Linear Elastic Isotropic            Yield strength: 1.72369e+008 N/m<sup>2</sup>            Tensile strength: 5.8e+008 N/m<sup>2</sup>            Elastic modulus: 1.93e+011 N/m<sup>2</sup>            Poisson's ratio: 0.27            Mass density: 8000 kg/m<sup>3</sup>            Thermal expansion coefficient: 1.6e-005 /Kelvin</p>	Ramp

### 5.3.3 Study Results (Stress)

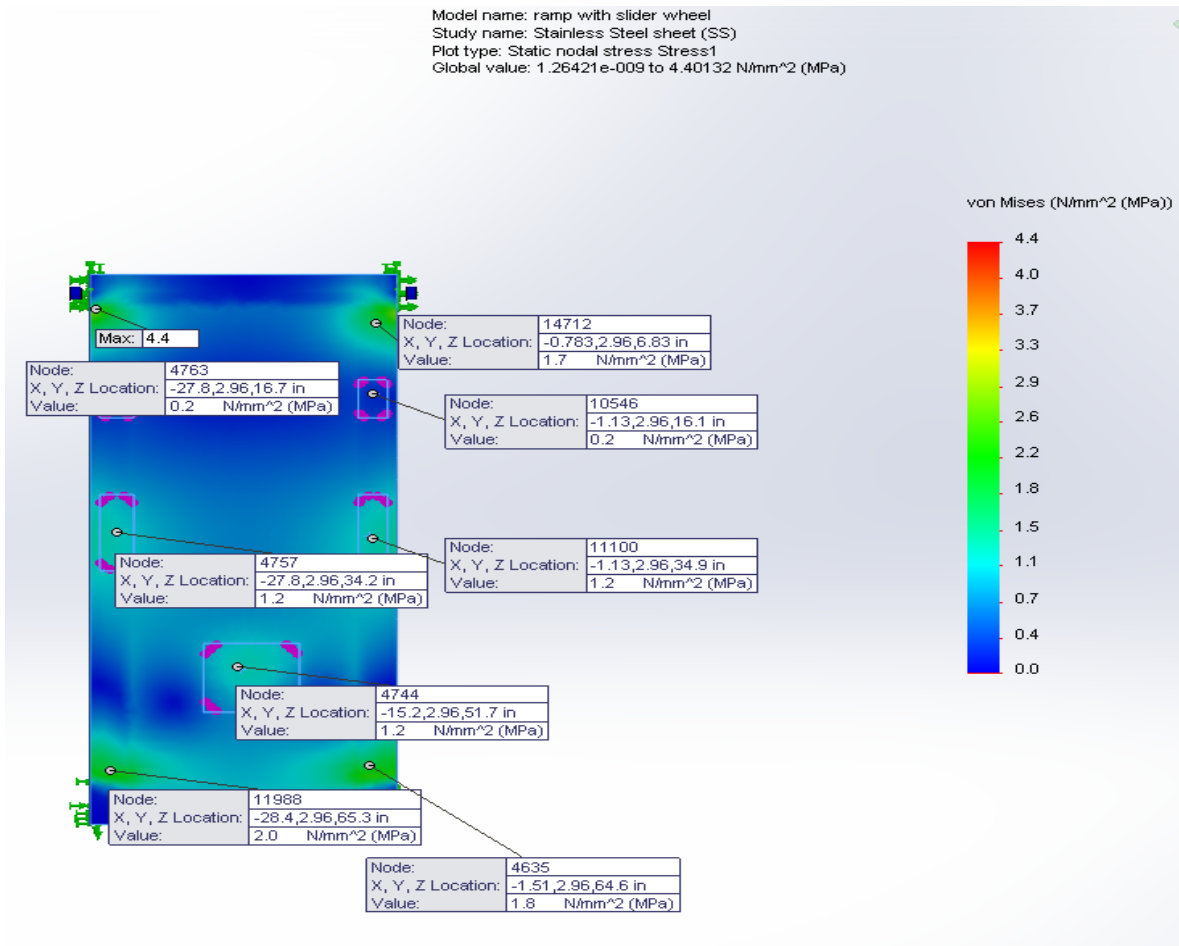

Figure 24 DS 3 Stress analysis

Table 14 DS 3 Stress analysis

Name	Yield Strength	Type	Min	Max
Stress	172.37 (MPa)	VON: von Mises Stress	1.26421e-009 (MPa)	4.40132 (MPa)

### 5.3.4 Study Results (FOS)

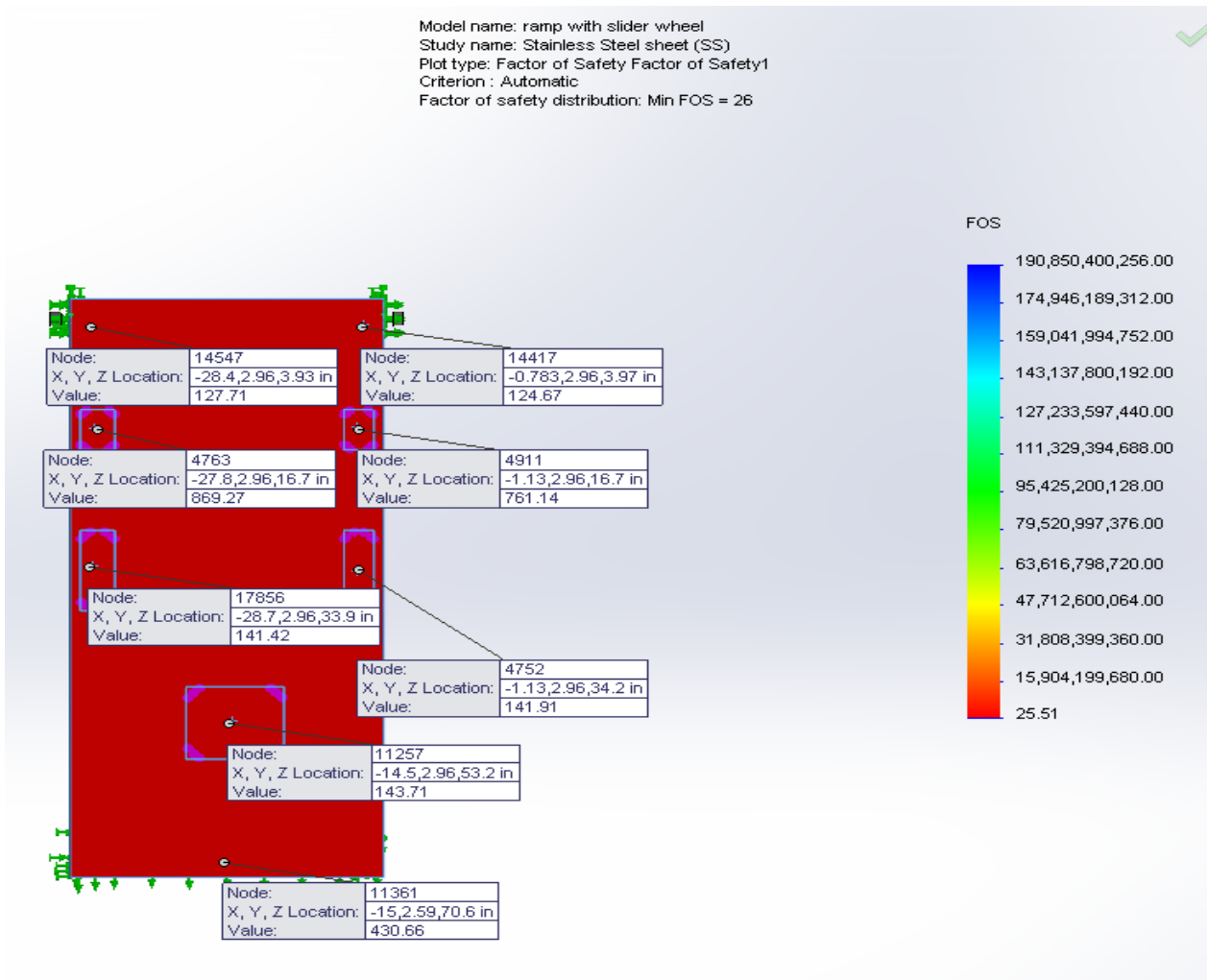

Figure 25 DS 3 FoS analysis

Table 15 DS 3 FoS analysis

Name	Min
Factor of Safety	26

### 5.3.5 Study Results (Displacement)

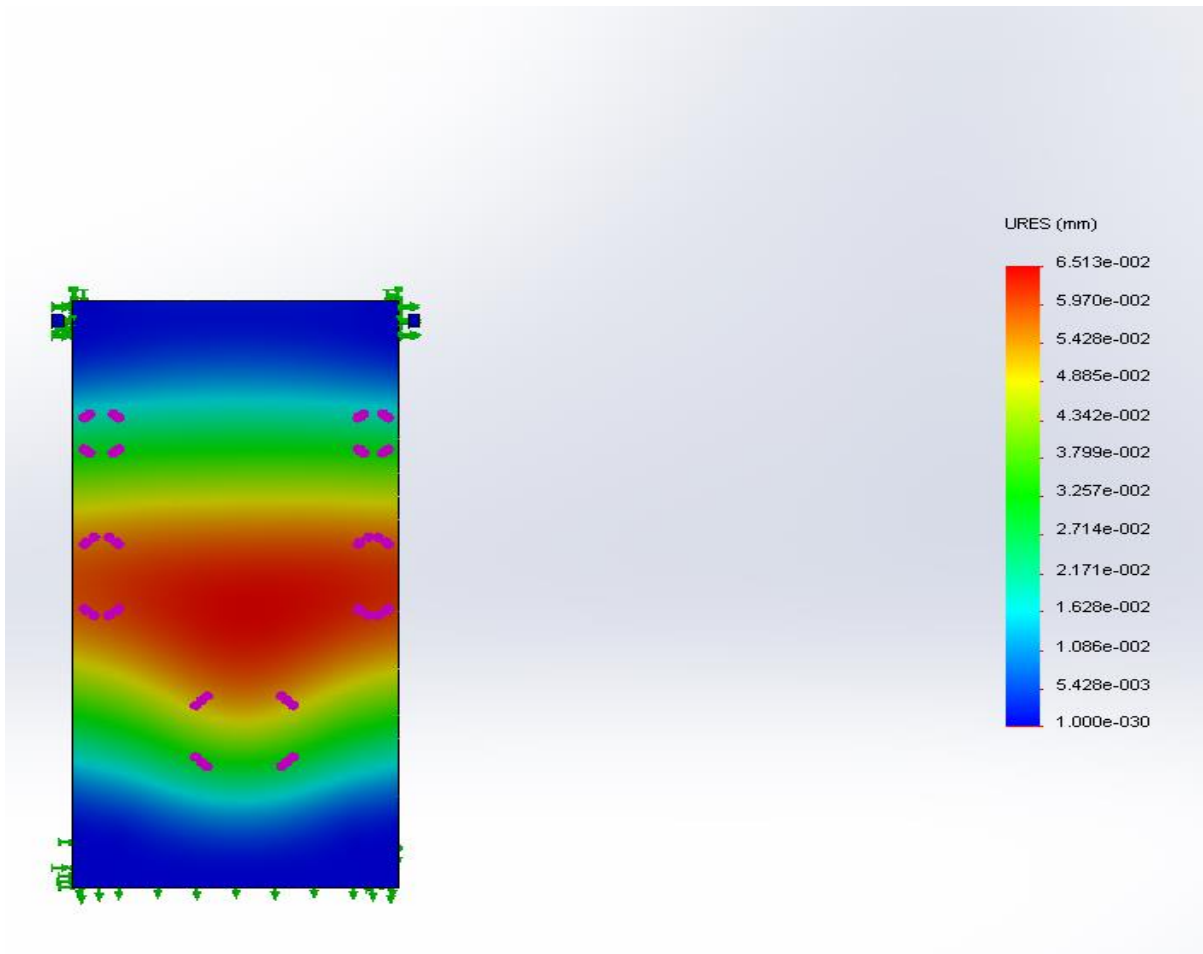

Figure 26 DS 3 Displacement analysis

Table 16 DS 3 Displacement analysis

Name	Type	Min	Max
Displacement	URES: Resultant Displacement	0 mm	6.513e-002 mm

## 5.4 Design Study 04

Material: Balsa wood



### 5.4.1 Model Information

Table 17 DS 4 Model Information

Figure	Treated As	Volumetric Properties
	Solid Body	Mass:5.76906 kg Volume:0.0360589 m <sup>3</sup> Density:159.99 kg/m <sup>3</sup> Weight:56.5368 N

### 5.4.2 Material Properties

Table 18 DS 4 Material Properties

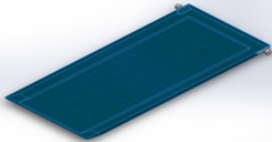
Model Reference	Properties	Components
	Name: Cast Alloy Steel Model type: Linear Elastic Isotropic Yield strength: 2.41275e+008 N/m <sup>2</sup> Tensile strength: 4.48082e+008 N/m <sup>2</sup> Elastic modulus: 1.9e+011 N/m <sup>2</sup> Poisson's ratio: 0.26 Mass density: 7300 kg/m <sup>3</sup> Shear modulus: 7.8e+010 N/m <sup>2</sup> Thermal expansion coefficient: 1.5e-005 /Kelvin	Slider hinge
	Name: ABS Model type: Linear Elastic Isotropic Tensile strength: 3e+007 N/m <sup>2</sup> Elastic modulus: 2e+009 N/m <sup>2</sup> Poisson's ratio: 0.394 Mass density: 1020 kg/m <sup>3</sup> Shear modulus: 3.189e+008 N/m <sup>2</sup>	Slider Wheel
	Name: Balsa Model type: Linear Elastic Isotropic Yield strength: 2e+007 N/m <sup>2</sup> Elastic modulus: 3e+009 N/m <sup>2</sup> Poisson's ratio: 0.29 Mass density: 159.99 kg/m <sup>3</sup> Shear modulus: 3e+008 N/m <sup>2</sup>	Ramp

### 5.4.3 Study Results (Stress)

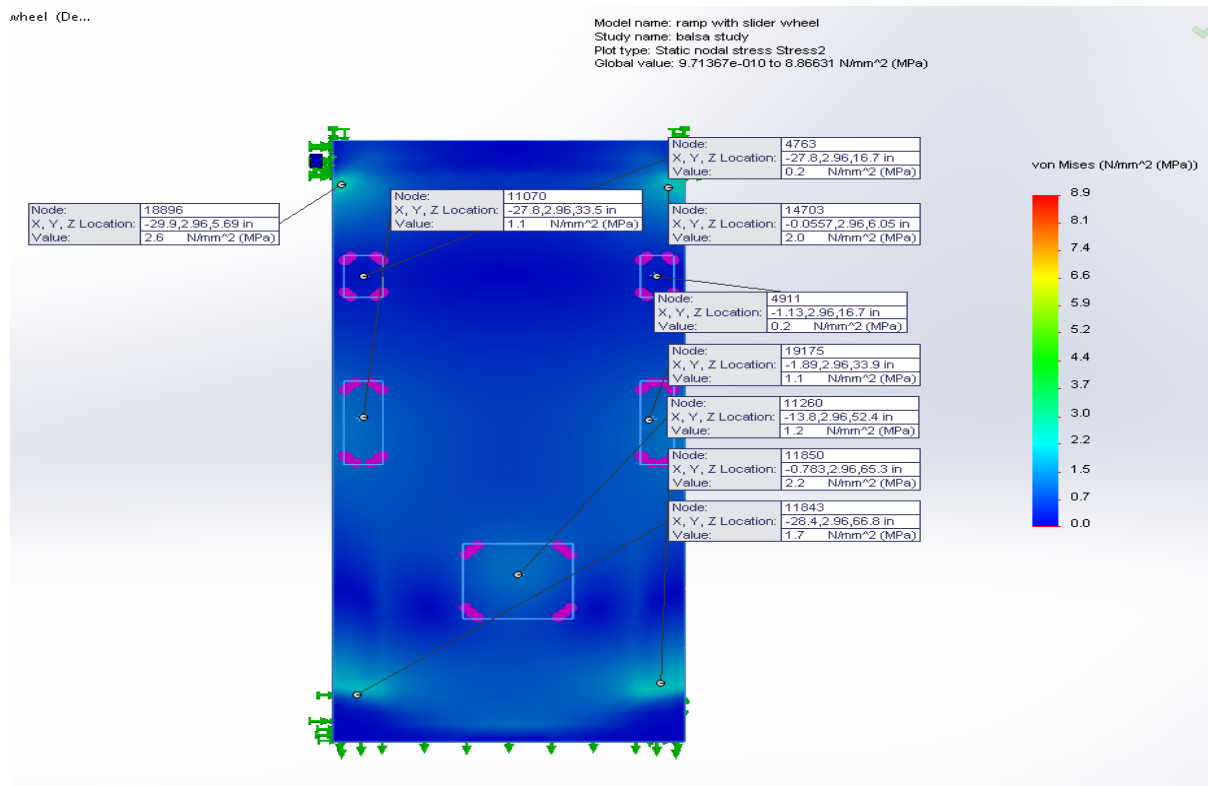

Figure 27 DS 4 Stress analysis

Table 19 DS 4 Stress analysis

Name	Yield Strength	Min	Max
Stress	20 (MPa)	9.71367e-010 (MPa)	8.86631 (MPa)

### 5.4.4 Study Results (FoS)

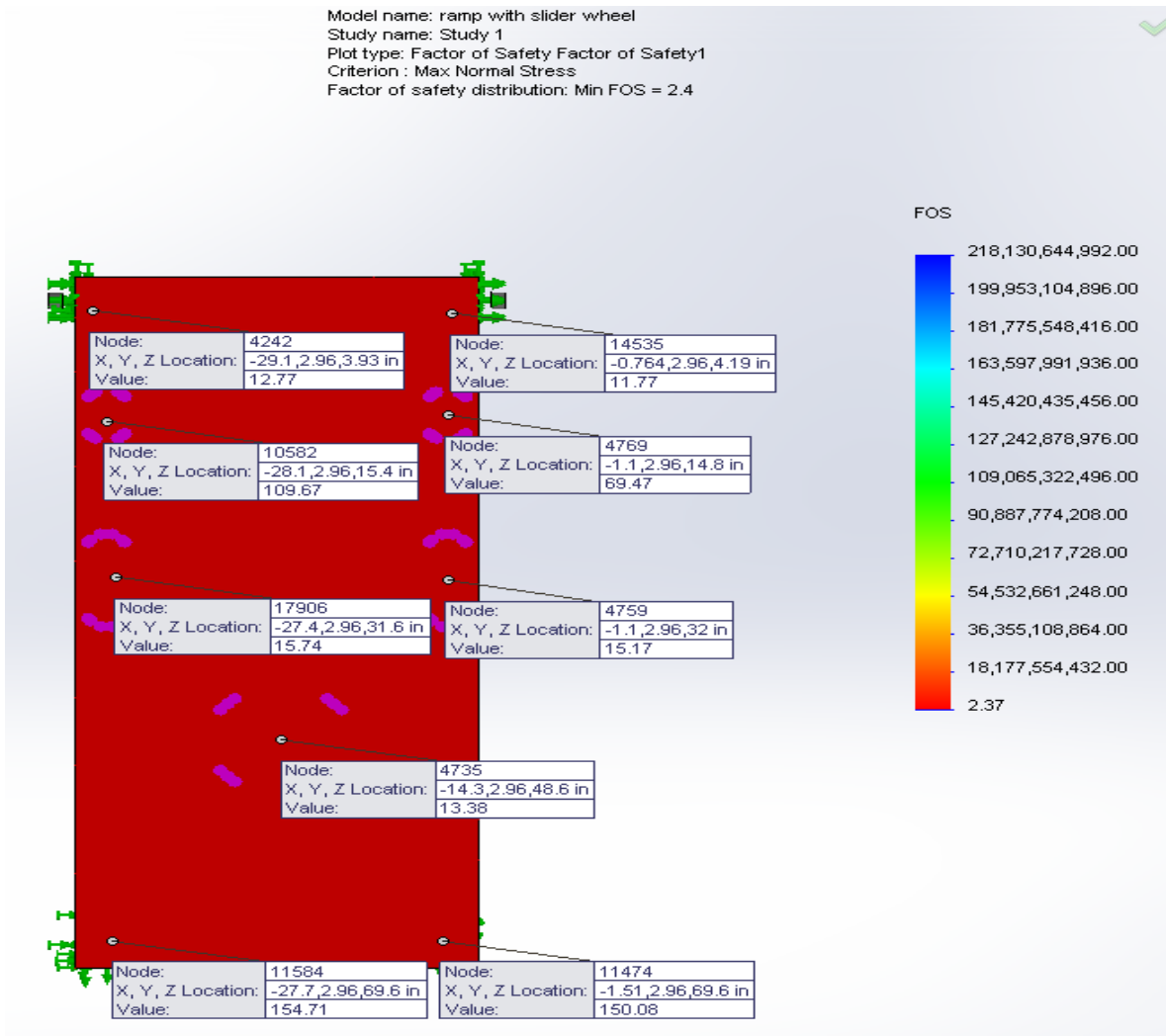

Figure 28 DS 4 FoS analysis

Table 20 DS 4 FoS analysis

Name	Min
Factor of Safety	2.4

### 5.4.5 Study Results (Displacement)

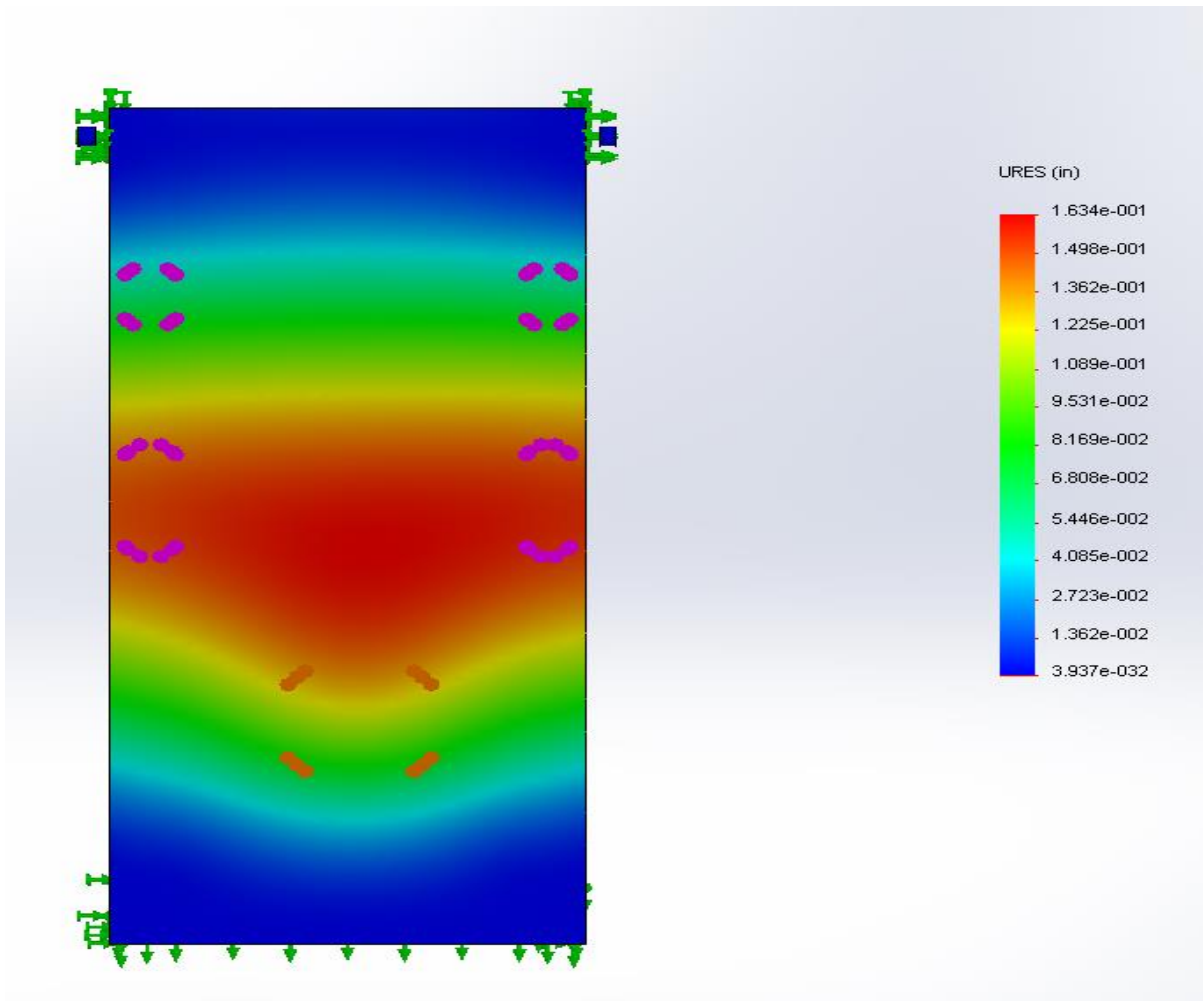

Figure 29 DS 4 Displacement analysis

Table 21 DS 4 Displacement analysis

Name	Type	Min	Max
Displacement	URES: Resultant Displacement	0 mm	4.15036mm



## 5.5 Graphical presentation of the results

Table 22 Material Comparison

Material	Weight(Kg)	Max. Stress (MPa)	Min. Factor of Safety(FOS)	Max. Displacement (mm)
Galvanized Steel	289.784	4.34888	31	0.062484
Stainless Steel	288.471	4.40132	26	6.51E-02
Aluminum	97.359	4.53161	4.82247	0.175785
Balsa Wood	5.76906	8.86631	2.4	4.15036

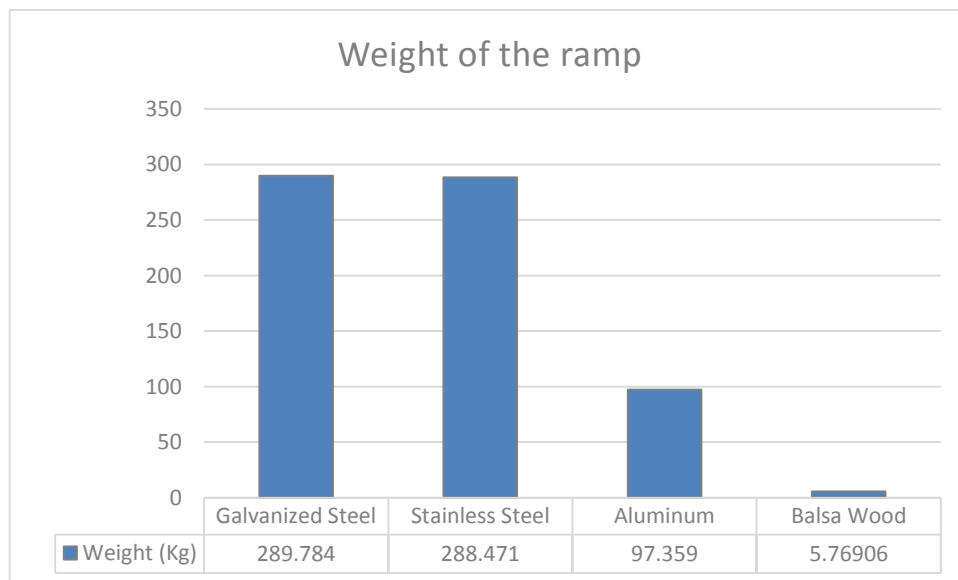

Figure 30 Graphical Presentation of weight of the ramp for Studied Materials

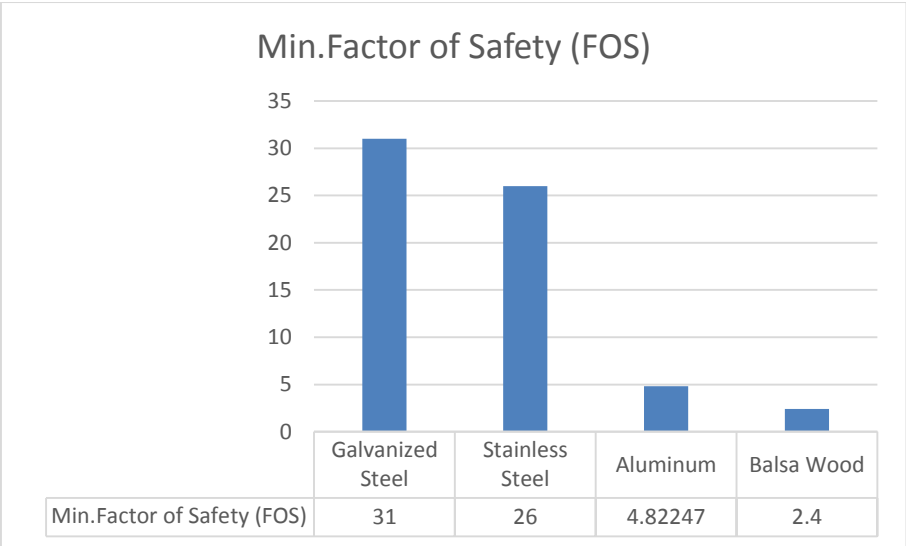

Figure 31 Graphical Presentation of Minimum FoS of the ramp for Studied Materials

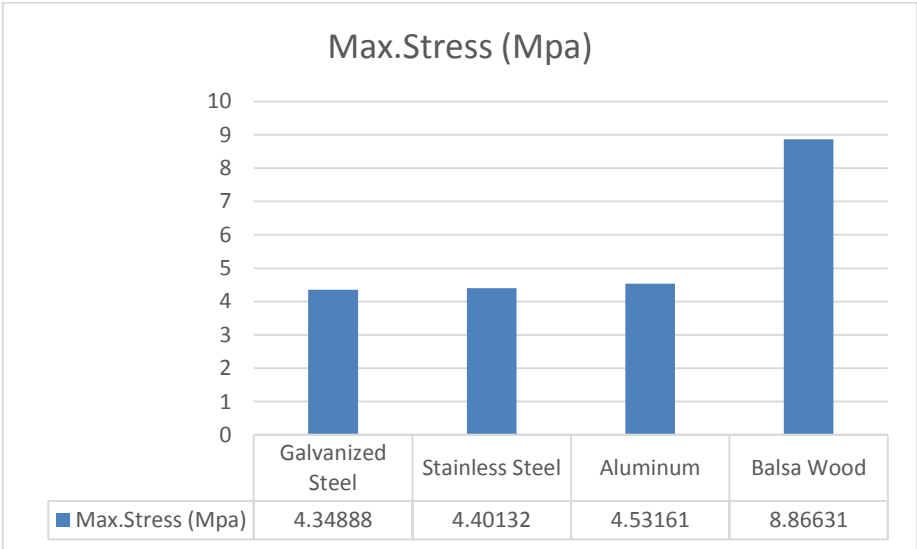

Figure 32 Graphical Presentation of maximum stress of the ramp for Studied Materials

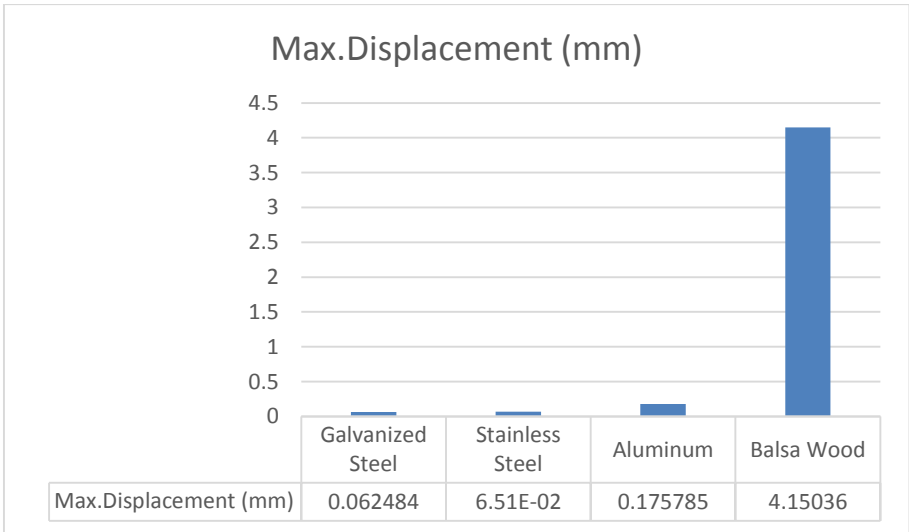

Figure 33 Graphical Presentation of maximum displacement of the ramp for Studied Materials

## CHAPTER 6

### Fabrication

The prototype is built for experimental purpose. The total cost of fabrication is relatively very low and took 3 hours to construct the full assembly.

#### 6.1 Materials Used in Different Parts

- Channel : Plywood, Aluminum channel
- Hinge : Mild Steel (MS)
- Wheels : White Nylon-6 Plastic-Wheel
- Ramp : Plywood

#### 6.2 Why Plywood

- Availability : Highly available in local Market
- Cost : Low cost compared to other materials
- Weight capacity: Better, can withstand significant amount of weight
- Light weight and Durable
- Easy to fabricate

##### 6.2.1 Plywood vs Balsa wood

Due to unavailability of material properties of Plywood, design study for plywood could not be conducted in Solid Works 2013 Simulation. However Plywood has higher density than Balsa wood, so we can assume that it will have higher load capacity, higher FoS and lower displacement than Balsa wood.

Balsa wood in Solid Works 2013 has a density of 160 kg/m<sup>3</sup>. On the other hand, the plywood available in local market in Dhaka city has a density of 490-510 kg/m<sup>3</sup>. The following table represents the properties of plywood that is available in local markets in Dhaka city.

Table 23 Physical properties of pitali and market Plywood

Species	Thickness (mm)	Density (kg/m <sup>3</sup> )	Moisture content (%)	Thickness swelling (%)	Linear expansion (%)	Water absorption (%)
<i>Trewia nudiflora</i>	18	509.82	10.67	6.90	0.19	50.89
<i>Bombax ceiba</i>	18	490.96	17.61	7.29	0.15	64.79

### 6.3 Fabricated Parts



Figure 34 Ramp body



Figure 35 Slider hinge and ramp assembly

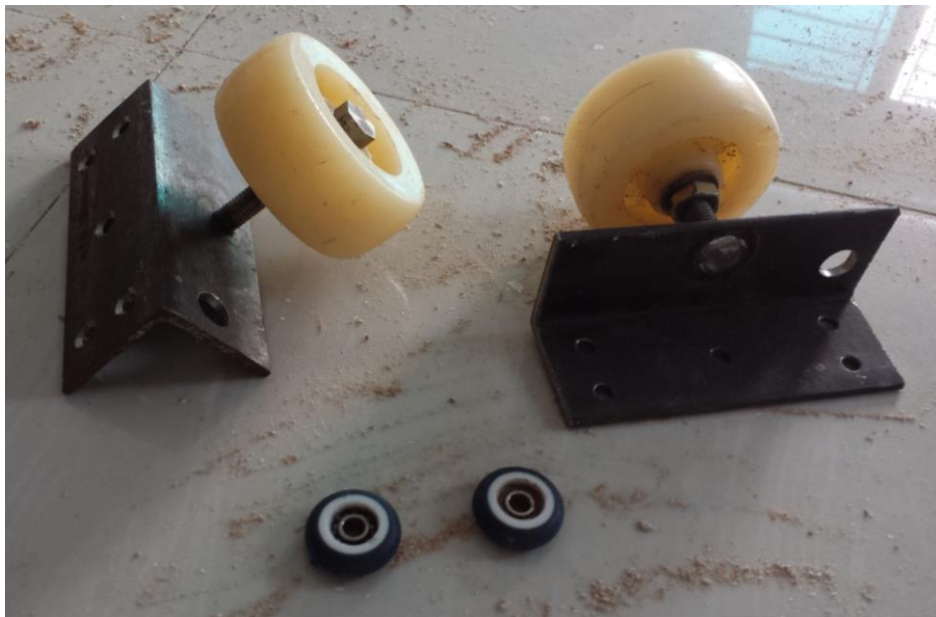

Figure 36 Slider Hinge



Figure 37 Slider



Figure 38 Full Assembly

## CHAPTER 7

### Conclusion

The design works properly in Solid Works 2013. Design study was conducted for the ramp body only, not the full assembly. The fabricated prototype has functioned properly. Though Plywood was used for fabrication for experimental purpose, it has some flaws regarding weather conditions in Dhaka city. The design study shows that if we use high yield strength material like Galvanized Steel, Stainless Steel (SS); it will have high load capacity but the weight of the ramp itself will be very high for portable use. In this regard, Aluminum is more suitable than any other materials which were studied. However further study should be done to find lighter, more durable and weather resistant materials for practical implementation on public buses in Dhaka city. Ramp weight reduction can be done by replacing the solid body with pattern holes.

The ramp that was fabricated operates manually. Automatic mechanism can be introduced by using electrical motors and hydraulic system. Further modification can be done to the interior of the bus.

## CHAPTER 8

### Reference

1. Lenker, J. A., U. Damle, C. R. D'Souza, E. Steinfeld. 2016. "Usability Evaluation of Access Ramps in Transit Buses: Preliminary Findings." *Journal of Public Transportation, Vol. 19, No. 2*: 109-113.
2. Abir, A. K. M. and M.S. Hoque. 2011. "A study on mobility problem of disabled people in Dhaka city." *4th Annual Paper Meet and 1st Civil Engineering Congress, Dhaka, Bangladesh*. ISBN: 978-984-33-4363-5.
3. Titumir, R. A., & J. Hossain. 2005. "Disability in bangladesh prevalence, knowledge, attitudes and practices"
4. ADA Wheelchair Ramp Code, ADA Guidelines & ADA Compliant. Retrieved on June 3,2017 from <https://www.adawheelchairramps.com/wheelchair-ramps/ada-guidelines.aspx>
5. Ramp Materials Selection. Retrieved on June 16, 2017 from <http://www.ramps.org/ramp-materials.htm>
6. Shahria, M.H., M. Ashaduzzaman, M. I. Shams, A. Sharmin and M. M. Islam. "Utilization of Pitali (*Trewia nudiflora*) for Manufacturing Commercial Plywood in Bangladesh." *Bangladesh J. Sci. Ind. Res.* 43(4) .(2008):581-587.
7. Ramp Slopes Encountered By Wheeled Mobility Device Users in Public Transit Buses. Retrieved on May 12, 2017 from <https://www.resna.org/sites/default/files/legacy/conference/proceedings/2013/Wheeled%20Mobility/Smalley.html>
8. Ramp Slope Guide. Retrieved on June 20, 2017 from <http://www.disabilitysystems.com/ramps/ramp-guide.html>
9. How to build RAMPS for home accessibility (THE RAMP PROJECT). Retrieved on August 09, 2017 from <http://www.accessnorth.net/cilnm/ramp.pdf>
10. Madiha, A., N. Campbell-Kyureghyan, G. Bertocci and K.L. Frost. 2012. "Ergonomic evaluation of a heelchair transportation securement system". *IOS Press*.
11. Bertocci, G., K. L. Frost, and C. Smalley. 2014. "Public transit bus ramp slopes measured in situ." *Disability & Rehabilitation: Assistive Technology: 1-6*.



12. Steinfeld, E., J. L. Maisel, D. Feathers, and C. R. D'Souza. 2010. "Anthropometry and Standards for Wheeled Mobility: An International Comparison." *Assistive Technology*, 22: 51-67.
13. Schneider, W., and A. Brechbuhl. 1991. "Defining the Low-Floor Bus: Its Advantages and Disadvantages." *49th UITP Congress, Stockholm*.
14. Rutenberg, U. 1995. "Urban Transit Bus Accessibility Considerations." *Rutenberg Design Inc., Canadian Urban Transit Association*.
15. Blennemann, F. 1991. "The Low Floor Bus Concept: Advantages for the Elderly and Handicapped." *Planning and Transport Research and Computation*, P349: 29-42
16. Steinfeld, E., S. Schroeder, and M. Bishop. 1979. "Accessible Buildings for People with Walking and Reaching Limitations." *U.S. Department of Housing and Urban Development, Washington, DC*.
17. Frost, K. L., G. Bertocci, and C. Smalley. 2015. "Ramp-Related Incidents Involving Wheeled Mobility Device Users during Transit Bus Boarding/Alighting." *Archives of Physical Medicine & Rehabilitation*, 96: 928-33.
18. National Council on Disability. 2005. *The Current State of Transportation for People with Disabilities in the United States*. Washington, DC. *National Council on Disability*.
19. RRC International. 1977. "Small Transit Bus Requirements Study: Performance Specifications for Advanced Design: Small Urban Transit Bus." *Urban Mass Transportation Administration*.