

بِسْمِ اللَّهِ الرَّحْمَنِ الرَّحِيمِ



*ISLAMIC UNIVERSITY OF TECHNOLOGY (IUT)*

*ORGANIZATION OF ISLAMIC CONFERENCE*

*DEPARTMENT OF TECHNICAL AND VOCATIONAL EDUCATION (TVE)*

## Room mapping and automatic vacuum cleaner robot.

Prepared  
by:

MD. HABIBULLAH

STUDENT NO: 143405

MD. SHARIF HOSSAIN

STUDENT NO: 143406

MD. BULBUL ISLAM

STUDENT NO: 143407

SUPERVISED BY

Md.Taslim Reza

Assistant Professor

Department of Electrical and Electronic Engineering(EEE)

Islamic University of Technology(IUT)

## DECLARATION

This is to certify that the work presented in this thesis is the outcome of the investigation carried out on **“Room mapping and automatic vacuum cleaner robot”** under the supervision of Md.Taslim Reza, Assistant Professor. This project work has not submitted elsewhere for obtaining any degree or certificate.

-----  
Md.Taslim Reza  
Assistant Professor  
Department of Electrical and Electronic Engineering (EEE)  
Islamic University of Technology (IUT)

-----  
Md.Habibullah  
Student No:143405

-----  
Md.Sharif Hossain  
Student No:143406

-----  
Md.Bulbul Islam  
Student No:143407

## **DEDICATION**

“Dedicated to our parents, whose enormous guidance and inspiration are beacons in our life”.

## **ACKNOWLEDGEMENT**

Firstly, all credit goes to Almighty who has given us the capability and opportunity to work in such an environment on such a topic. We wish to thank our supervisor Md. Taslim Reza for his tireless guidance, encouragement, patience, and support. Guiding us on every aspect of research and providing feedback on most of this work, in addition to being a mentor and a friend. We also want to thank the other members of my thesis committee for their feedback and kind help. I am grateful to our supervisor Md. Taslim Reza, Assistant Professor, Department of Electrical and Electronic Engineering, Islamic University of Technology; for his frequent encouragements and comments.

We would like to thank the members of the Advanced Electronics Lab, which has been an extraordinary environment to work in. The people in the lab remind us of how much we have yet to learn to become a skilled roboticsit.

We would also like to thank many members of the Robotics who have helped us to reach this milestone, including some of my classmates and friends over the years.

Lastly, we would like to thank our group members for giving financial support and encouragement to build this project.

## **ABSTRACT**

As robots enter the human environment and come in contact with inexperienced users, they need to be able to interact with users in a multi-modal fashion keyboard and mouse is no longer acceptable as the only input modalities. Humans should be able to communicate with robots using methods as similar as possible to the concise, rich, and diverse means they use to communicate with one another.

The framework is demonstrated by interactively controlling and programming a vacuum-cleaning robot. The demonstrations are used to exemplify the interactive programming and the plan recognition aspect of the research. The key contributions of this thesis are the introduction and implementation of the novel programming approach. It is expected to improve significantly the state-of-the-art in robot programming and interactive personal robotics.

# Table of Contents

|  |    |
|--|----|
| CHAPTER 1 .....  | 8  |
| 1.1 Motivation .....   | 8  |
| 1.2 Goals.....   | 9  |
| CHAPTER 2.....   | 10 |
| Related works.....   | 10 |
| 2.1 Literature review: .....   | 10 |
| 2.2 Different Types of sensor.....                                       | 11 |
| 2.3 Different types of robots. ....                                      | 13 |
| 2.3.1 Autonomous Room Mapping Robot: .....                               | 13 |
| 2.3.2 Cleaning vacuum i7 robot: .....                                    | 17 |
| 2.4 General Objective.....   | 25 |
| CHAPTER 3 .....  | 32 |
| 3.1. An overview of fundamental cleaning robots and main Patentees ..... | 32 |
| 3.2 Location recognition and navigation .....                            | 32 |
| 3.3 Samsung utilized camera and remote control.....                      | 33 |
| 3.4 iRobot utilized barrier signals as a virtual wall .....              | 33 |
| 3.5 How to develop adjustable brush and air cleaning.....                | 34 |
| 3.6 Cleaning modes and obstacle avoidance .....                          | 35 |
| 3.7 iRobot constructed complete cleaning mode.....                       | 35 |
| 3.8 Problem statement .....  | 35 |
| CHAPTER 4 .....  | 36 |
| Design and methodology.....  | 36 |
| 4.2 Design a mapping circuit.....  | 36 |
| 4.3 Parts of materials (Table of equipment's) .....                      | 37 |
| 4.4 Circuit Design (mapping).....  | 38 |
| 4.5 Designed for various obstacles .....                                 | 39 |
| CHAPTER 5 .....  | 40 |
| System Implementation.....   | 40 |

|  |           |
|--|-----------|
| 5.1 Mapping Design .....                                     | 40        |
| 5.2 Map generalization .....                                 | 40        |
| 5.3 Robotics design .....                                    | 41        |
| 5.4 Suitable materials for design .....                      | 42        |
| 5.5 Construction methods are appropriate to the design ..... | 42        |
| 5.6 Programming and Testing Robot.....                       | 43        |
| 5.7 Evaluating Their Robot .....                             | 43        |
| 5.8 iRobot used emitter to come home.....                    | 44        |
| CHAPTER 6 .....  | 45        |
| Conclusion.....  | 45        |
| REFERENCES .....   | 46        |
| APPENDIX - I .....   | 50        |
| <i>Programming code</i> .....                                | <b>50</b> |

# CHAPTER 1

## Introduction

Robots are becoming more and more common in our daily lives showing up in the form of everything from children's toys, to robotic vacuum cleaners, to home security robots. Robots have been doing automated tasks in factories for decades. With the ever-increasing speed and power of digital systems coupled with the continuously expanding field of robotics, it is becoming more practical to build custom robotic systems with a degree of flexibility and freedom that was once impossible, giving robots the ability to communicate wirelessly or to act autonomously. Now, instead of robots simply performing manual tasks such as repetitive jobs at factories, robots can perform jobs once thought to be reserved for humans, without the risk of danger to a human life.

Such a robot, if it could perform its duties safely and reliably, would be of immense value to any rescue operation. The robot prototype designed and built for this major qualifying project was meant to be a starting point for such a robot; due to time and budget constraints building a fully functional search and rescue robot was not feasible. By designing and building the autonomous mapping robot many steps were taken towards the design of a fully functional search and rescue robot.

### 1.1 Motivation

An important aspect of a successful robotic system is the human-machine interaction. As robots enter the human environment and come in contact with inexperienced users, they need to be able to interact with users through a novice friendly interface and the burden of knowledge transfer from the user to the robot. In terms of human machine Interface, interaction should be done in a multi-modal fashion— keyboard and mouse are no longer acceptable as the only input modalities. Humans should be able to communicate with robots using methods as similar as possible to the concise, rich, and Diverse means they use to communicate with one another.

In terms of human-machine knowledge transfer, an expert in the task who is not necessarily a robot programmer may need to rely on a robot programming expert to convey his knowledge to the system.

Humans should be able to transfer knowledge without relying on a robot programming expert.



## 1.2 Goals

The goal of this work is to create a Programming by Interaction (PBI) system that enables users to control and program a robot interactively through an intuitive interface. We also verify the system's advantage in programming experience and performance through empirical user study on mobile vacuum cleaning robot. The system with intention awareness models recognizes and makes suggestions based on the user's intention. The user's intent is captured in the form of a sequential robot Program and the flexibility given to the user through real-time interaction and the framework's intuitive interface allows the captured intent to be closer to what the user really expects from the robot. Sequential robot programs are converted to statistical models.

So that partial inputs from the user can be used by the system in future to recognize the robot program that the user may want to execute. The suggestion is made through a graphical display, where a simulated robot executes the task so that the user can choose to accept or decline the offer.

## CHAPTER 2

### Related works

#### 2.1 Literature review:

We studied about different types robots and different type's project which are related with arduino base robot. Then we select to build this type of robot. Ultrasonic sensor is used for obstacle avoiding and with Arduino UNO, which can be programmed which makes it completely automatic. The front rolling brush is attached in the front section, helps in collecting the dust. The front section can be fixed with a vacuum cleaning system to collect the dust gathered by the rolling brush. The back portion of the robot is attached with a swabbing cloth for swabbing of the floor. A small water tank can be provided to keep the cloth moist. Swabbing cloth is provided with magnet for easy attachment and detachment.

It is provided with a rechargeable battery and four gear motors which help in the movement of the robot. We're learning to love our machines—or, at least, that's how it's starting to seem! Things have come an awfully long way since the early 19th-century, when an infamous band of textile workers called the Luddites smashed up the machines they feared were stealing their jobs. What would they make of life 200 years later, when most products come from highly automated factories and many of us are now inviting robots into our homes? It's still very early days for household robots, but a popular little machine called the automatic room mapping and dust cleaner robot could be the shape of things to come. It's a small, computerized cleaner that nips round their house automatically brushing and vacuuming the carpets, rugs, and floors. This is a step by step guide to build an automatic cleaner robot.

We use the Arduino microcontroller to control this robot. We have two different programs for this robot. The first enables the robot to drive around and avoid anything that gets in its way. This avoiding obstacles program uses two ultrasonic sensors.

An important challenge in small-scale robotics is finding a robot's position when only limited sensor information is available. There are many technologies available for robot localization, including GPS, active/passive beacons, odometer (dead reckoning), sonar, etc. In each approach,

however, improvements in accuracy come at the cost of expensive hardware and additional processing power. For the robotics enthusiast, the key to successful localization is getting the best results out of cheap and widely available sensors. This paper presents a method for localization and map construction of a mobile robot using data from a sonar-based range sensor. No prior knowledge of the environment is assumed.

## 2.2 Different Types of sensor

**Ultra sound sensor: Ultrasonic Sensor** The principle of ultrasonic sensor is similar to sonar or radar in which interpretation of echoes from radio or sound waves to evaluate the attributes of a target by generating the high-frequency-sound waves (around 40kHz). The transducer used for converting energy into ultrasound or sound waves with ranges above human hearing range is called an ultrasonic transducer. **Application of Ultrasonic Sensor** The distance measurement at inaccessible areas is a typical application of ultrasonic sensors.

The circuit consists of an ultrasonic module, LCD display and microcontroller. The ultrasonic module is interfaced with the microcontroller and this ultrasonic transducer consists of a transmitter and receiver. **Ultrasonic Sensor Application by Edgefxkits.com.**The waves transmitted by transducer are received back again after the waves are reflected back from the object. The velocity of sound is considered for calculating time taken for sending and receiving waves.

The distance is calculated by executing a program on microcontroller, and then it is displayed on the LCD display. There are many sensors such as humidity sensor, gas sensor, pressure sensor, water sensor, leaf sensor, rain sensor, tilt sensor, rate sensor and so on, which are being used in many applications.

If they are interested to know in detail about sensors, then they can approach us for any technical help regarding different types of sensors and their applications and also to develop sensor based projects by posting their queries in comments section below.



Figure 2.1: Ultra sound sensor <sup>[33]</sup>

**Light sensor:** The Light Sensor approximates the human eye in spectral response. Use it for inverse square law experiments or for studying polarizer's, reflectivity, or solar energy. They look at the light sensing process—incoming light converted to electrical signals sent to the brain—through the human eye anatomy as well as human-made electrical light sensors. A Light Sensor is something that a robot can use to detect the current ambient light level - i.e. how bright/dark it is. There are a range of different types of light sensors, including 'Photo resistors', 'Photodiodes', and 'Phototransistors'

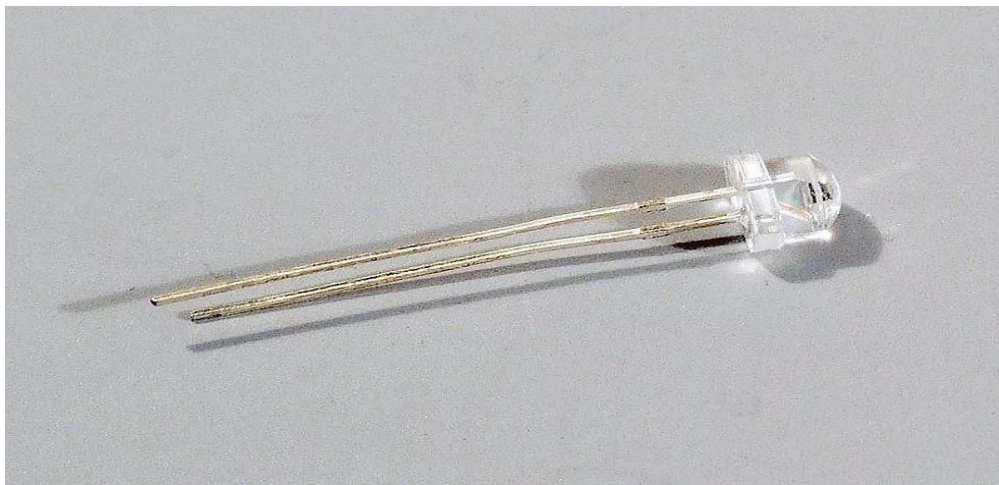

Figure 2.2: Light sensor<sup>[42]</sup>

**Proximity sensor:** A proximity sensor is a sensor able to detect the presence of nearby objects without any physical contact. A proximity sensor often emits an electromagnetic field or a beam of electromagnetic radiation (infrared, for instance). Proximity Sensors are available in models using high-frequency oscillation to detect ferrous and non-ferrous metal objects and in capacitive models to detect non-metal objects. Models are available with environment resistance, heat resistance, resistance to chemicals, and resistance to water.



Figure 2.3: Proximity sensor <sup>[38]</sup>

## 2.3 Different types of robots.

### 2.3.1 Autonomous Room Mapping Robot:

An autonomous robot is a robot that performs behaviors or tasks with a high degree of autonomy, which is particularly desirable in fields such as spaceflight, household maintenance (such as cleaning), waste water treatment and delivering goods and services.

Some modern factory robots are "autonomous" within the strict confines of their direct environment. It may not be that every degree of freedom exists in their surrounding environment, but the factory robot's workplace is challenging and can often contain chaotic, unpredicted variables. The exact orientation and position of the next object of work and (in the more advanced factories) even the type of object and the required task must be determined. This can vary unpredictably (at least from the robot's point of view).

One important area of robotics research is to enable the robot to cope with its environment whether this is on land, underwater, in the air, underground, or in space.

A fully autonomous robot can:

1. Gain information about the environment
2. Work for an extended period without human intervention

3. Move either all or part of itself throughout its operating environment without human assistance
4. Avoid situations that are harmful to people, property, or itself unless those are part of its design specifications.

An autonomous robot may also learn or gain new knowledge like adjusting for new methods of accomplishing its tasks or adapting to changing surroundings. Like other machines, autonomous robots still require regular maintenance. The internal representation of the map can be "metric" or "topological":

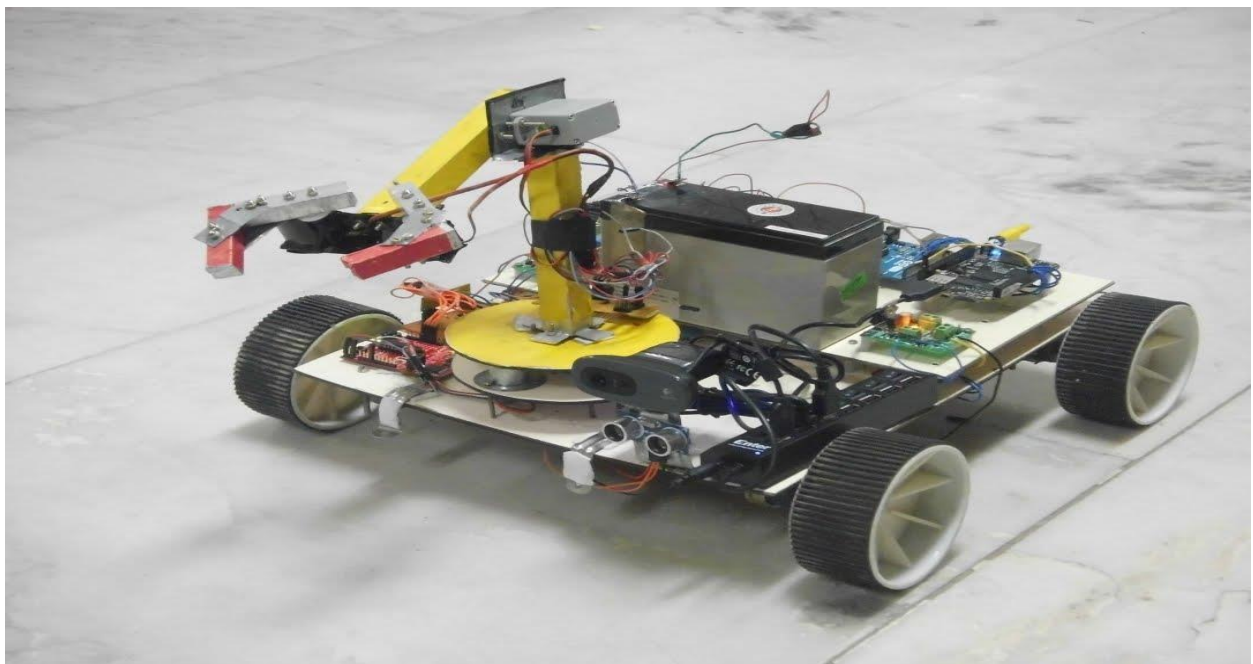

Figure 2.4: An autonomous robot [45]

### **Representation robot:**

The metric framework is the most common for humans and considers a two-dimensional space in which it places the objects. The objects are placed with precise coordinates. This representation is very useful, but is sensitive to noise and it is difficult to calculate the distances precisely.

The topological framework only considers places and relations between them. Often, the distances between places are stored. The map is the graph, in which the nodes corresponds to places and arcs correspond to the paths.

Many techniques use probabilistic representations of the map, in order to handle uncertainty.

There are three main methods of map representations, i.e., free space maps, object maps, and composite maps. These employ the notion of a grid, but permit the resolution of the grid to vary so that it can become finer where more accuracy is needed and coarser where the map is uniform.

### **Map learning:**

Map learning cannot be separated from the localization process, and a difficulty arises when errors in localization are incorporated into the map. This problem is commonly referred to as simultaneous localization and mapping. An important additional problem is to determine whether the robot is in a part of environment already stored or never visited. One way to solve this problem is by using electric beacons, Near field communication (NFC), Wi-Fi, Visible light communication (VLC) and Li-Fi and Bluetooth.

### **Path planning:**

Path planning is an important issue as it allows a robot to get from point A to point B. Path planning algorithms are measured by their computational complexity. The feasibility of real-time motion planning is dependent on the accuracy of the map (or floor plan), on robot localization and on the number of obstacles. Topologically, the problem of path planning is related to the shortest path problem of finding a route between two nodes in a graph.

### **Top Challenges in Robotics**

- Better Batteries
- Better Actuators
- Industry-Grade Robotics Software
- Software In-Work.

## **Industry-Grade Robotics Software**

The biggest challenge expressed by experts is the one I am most excited about. Roboticists need powerful software to design their autonomous systems. Software that is not unique to a particular robot or task, is open to incorporate existing algorithms, and is powerful enough to solve problems we do not even understand today.

This is the challenge I see being met the soonest. With Their input and some of the leading software developers in the world, we can empower designers with a powerful software package within a year's time. The most opposing force is mind-set. Robotics in Paris, France was recently quoted on Slashdot.org saying, -It's easier to build everything from the ground up right now.!

This is the mind-set of the last decade in robotics and the reason we have not seen massive adoption or progress in our field. Instead, we need to see some convergence of technology and enable the innovation we need to make the kind of impact that robots can. Thus, robotics needs standard, industry-grade software.

## **Software intuitively**

Many roboticists have a mechanical engineering or electrical engineering background and do not have the time or money to learn the ins and outs of the most useful computer science techniques, but they do need to be able to take advantage of those techniques. Programming capabilities like object-oriented programming and recursion can be critical in a robust autonomous system, so they need a language that is capable of these features.

## **The software must integrate well with I/O**

Every autonomous system must sense or perceive the world around it as well as act on that environment. Sensing requires input from external sensors such as laser rangefinders and sonar sensors, and acting requires the ability to drive many different types of actuators. In addition to sensing and acting, their software tool must easily implement their application on real hardware, meaning it must



have strong integration with real-time OSs, real-time embedded hardware, and even FPGA-based devices.

Many software packages, including Microsoft Robotics Studio, on the market lack this capability – they can simulate and run on their development machines but fail to provide any kind of real-time implementation capability.

### **The software must be open and flexible**

Many autonomous algorithms have already been optimized and are ready to be reused, and the building blocks of others have been created but need to be built on for greater capabilities. For example, many roboticists wish to start from those basic algorithms and add their own innovation or latest research on top of those building blocks to create a new type of search or integrate them with a new mapping technique to aid robot rescue or medical assist applications.

The closed nature of many robotics software packages today frustrates design engineers. Packages like iRobot aware work fine for their robots but cannot be used for customization or for their own unique robotic design.

### **The software must be interactive**

Innovative robot design is not straightforward and requires many iterations and prototypes. The software used to design the robot should be able to accommodate and enhance this experience. Roboticists need a software package that they can easily debug, that integrates intuitive simulation, and can quickly be implemented on a real-time hardware system to test the algorithms and design with real- world I/O. That same code then needs to easily port back to the design environment for additional optimizations or software tweaks.

#### **2.3.2 Cleaning vacuum i7 robot:**

The i7 vacuum robot was designed to clean homes and is good for a wooden and ceramic floor plus short-haired carpet (Pursonic i7 vacuum cleaner robot, 2012). The i7 robot is an advanced cleaning robot with various intelligent cleaning modes. It has wall-detection sensors and anti-fall

sensors to detect edges. These sensors make the cleaning robot smarter. The cleaning time can be scheduled to be done daily, weekly or on a specific date. The i7 cleaning robot can be controlled remotely using a remote control.

The i7 vacuum-cleaning robot is designed to work on a flat surface, so some change required to the structure and software to enable it to work on PV panels at different



Figure 2.5: i7 robot<sup>[49]</sup>

i7 Vacuum Robotic Multifunction:

Boasting a series of automated functions, this time-saving robotic vacuum can be programmed to clean and sterilize floors while they're at work or running errands.

- 4-in-1 functionality to sweep, mop, sterilize, and vacuum floors
- Recommended for tiles, thin carpet, linoleum, and wood flooring
- Programmable cleaning schedule
- Remote control for hands-free operation
- HEPA filter system traps dust, allergens, and tiny particulates
- Advanced cleaning head picks up pet hair, dirt and dust
- UV bulb technology kills bacteria
- Virtual wall set system sets invisible boundaries
- Touch screen controls
- Alarm indicates when dust compartment is full
- Cliff sensor avoids stairs and drop-offs
- Soft bumper to protect the unit and furniture

- 90-minute battery life
- Automatically recharges after cleaning or when battery is low
- Product Dimensions: 15.75" x 18.75" x 5.75"
- Product Weight: 8lb.
- Included accessories: charging home base, remote control, virtual wall, extra side brush, HEPA filter, mop, cleaning tool, and charging adapted

### **2.3.3 iRobot Roomba 980 Vacuum Cleaning**

#### **Robot: Introduction**

Service robots have been getting popular in recent years, these robots operate semi- or fully autonomously to perform services useful to the well-being of humans and equipment. Service robots of different varieties including medical robots, underwater robots, surveillance robots, demolition robots and other types of robots those carry out a multitude of jobs. They can clean floors, mow lawns and guard homes and will also assist old and handicapped people, do some surgeries, inspect pipes and sites that are hazardous to people, fight fires and defuse bombs. This paper will focus on a service robot of everyday tools for mankind, a cleaning robot in home.

Residential robots are quite different from industrial robots because of nonprofessional users. It needs high reliability and safety. Autonomous cleaning robots are getting more popular for aging populations, it is necessary to design 'really autonomous' robots, easy to stagnate or stasis are not allowable, especially for old users. 'A robot in every home?' reported by Science News in 2004, 'In the home, by the end of 2003, about 610,000 autonomous vacuum cleaners and lawn-mowers were in operation, the report says. Between 2004 and 2007, more than 4 million new units could be added, it adds.' New market induced companies devoted to new and functional robots design to get higher market share. In technical development of varieties and advanced robots, one can find hundreds of papers.

Many advanced robots have powerful functions but still a big gap to commercialization. This paper analyzed commercial robots by US granted patents, companies always file patent in advance for their commercial products, granted patents are also a powerful weapon to stop competitors enter their claim technology under its exclusive rights. Patent analysis for special technical topics can evaluate patent and find the occupied technology, it is helpful and necessary before R&D.

Macroscopic of analysis including patent bibliometrics, patent citation analysis, to determine strength and value of a patent based on patent numbers. Patent maps are useful tools to visualize the distribution of patents, monitor the trend of technological changes, infer the strategy of patent portfolios, and compare competitors by statistical charts or diagrams.

Macroscopic point of view may misconstrue patent value because lack of case review. The value of Intangible assets should not be estimated only on its numbers. On the contrary, microscopic point of view can construct technical value for each patent but need labors and time. Both points of view applied in this paper, to make a technical strength and development analysis of modern residential cleaning robots by US granted patents. An overview of patent numbers and main patentees in cleaning robots first, then the attained US granted patents were classified and formed a bubble map, two major patentees, iRobot and Samsung, were competitors and analysis under macro and micro point of view.

### **History of iRobot:**

iRobot was founded in 1990 by Rodney Brooks, Colin Angle and Helen Greiner after working in MIT's Artificial Intelligence Lab. In 1998 the company received a DARPA research contract which led to the development of the PackBot. In September 2002, iRobot unveiled its home robots flagship, the Roomba, which sold a million units by 2004.

iRobot began being traded on the NASDAQ in November 2005, under ticker symbol IRBT. On September 17, 2012, iRobot announced that it had acquired Evolution Robotics, manufacturer of automated floor mapped Mint. iRobot has sold more than 8 million home robots,

and has deployed more than 5,000 defense & security robots, as of 2012.

In addition to deployment as bomb-disposal units with the US military in Iraq and Afghanistan, PackBots have been used to gather data in dangerous conditions at the Fukushima Daiichi nuclear disaster site, and an IRobot Sea glider detected underwater pools of oil after the Deep-water Horizon oil spill.

iRobot has been criticized for attempting unregulated use of 6240-6740 MHz band, and asking for an FCC exemption to do so. This band is for use for the lawn mowing robot without needing to use an electronic fence as a boundary marker, instead by using radio beacons. The band falls into a band reserved for radio astronomy use, thus interfering with radio telescope observations of methanol's 6.66852 GHz emissions.

### **Operation:**

Long exposure photo showing path taken by a Roomba as it cleans .All Roomba models can be operated by manually carrying them to the room to be cleaned and pressing a button. Later models introduced several new operating modes. Clean mode is the normal cleaning program, starting in a spiral and then following a wall, until the room is determined to be clean. Spot mode cleans a small area using an outward-then-inward spiral. Max mode runs the standard cleaning algorithm until the battery is depleted. Dock mode, introduced with the third generation, instructs the robot to seek a charging base for recharging. The availability of the modes varies by model.

The robot's bumper allows it to sense when it has bumped into an obstacle, after which it will reverse or change paths. The third- and fourth-generations, which move faster than previous models, have additional forward-looking infrared sensors to detect obstacles. These slow down when nearing obstacles to reduce its force of impact. This technology is also able to distinguish between soft and solid barriers. After enough time cleaning, the Roomba will either search for and dock with the base, or stop where it is.

The cleaning time depends on room size and, for models equipped with dirt sensors, volume of dirt. First-generation models must be told the room size, while second- and third-generation models estimate room size by measuring the longest straight-line run they can perform without bumping into an object. When finished cleaning, or when the battery is nearly depleted, a second- or third-generation Roomba will try to return to a base if one is detected. A second-generation Roomba may also be used with a scheduler accessory, allowing cleaning to start at the time of day and on days of the week that the owner desires. Most 500 Series robots support scheduling through buttons on the unit itself, and higher-end models allow the use of a remote to program schedules.

Unlike the Electrolux Trilobite vacuuming robots, Roombas do not map out the rooms they are cleaning. Instead, iRobot developed a technology called adapt Responsive Cleaning Technology. Roombas rely on a few simple algorithms such as spiral cleaning (spiraling), room crossing, wall-following and random walk angle-changing after bumping into an object or wall. This design is based on MIT researcher and iRobot CTO Rodney Brooks' philosophy that robots should be like insects, equipped with simple control mechanisms tuned to their environments. The result is that although Roombas are effective at cleaning rooms, they take several times longer to do the job than a person would. The Roomba may cover some areas many times and other areas only once or twice. The virtual wall accessories project beams which the Roomba will not cross.

The Roomba is not designed for deep-pile carpet. Also, the first- and second-generation Roombas can get stuck on rug tassels and electrical cords. The third-generation is able to reverse its brushes to escape entangled cords and tassels. Additionally, all models are designed to be low enough to go under a bed or most other items of furniture. If at any time the unit senses that it has become stuck, no longer senses the floor beneath it, or it decides that it has worked its way into a narrow area from which it is unable to escape, it stops and sounds an error to help someone find it. Early models use only flashing lights to indicate specific problems, while later models use a voice to announce a problem and a suggested solution.

## **Top 5 Advantages of the iRobot Roomba:**

### **Hands-Free Cleaning**

The iRobot Roomba offers hands-free cleaning for any floor surface. It cleans carpets of a variety of thickness levels, as well as smooth floor surfaces, such as hardwood, tile, or linoleum. Consumers do not need to be present while the Roomba is in operation. The smart sensors on the machine and the settings the user chooses keep the iRobot vacuum performing the task without malfunction. The iRobot Roomba offers a variety of cleaning modes and behaviors.

Not all iRobot Roomba series offer the dirt detection or scheduling mode. The cleaning behaviors, such as crisscrossing and spiraling are common to all models.

### **Smart Sensors**

The Smart sensors on the iRobot Roomba tell the vacuum when to change directions to avoid obstacles, as well as where to go to locate dirt and debris. Consumers with stairs or drop offs in their home do not need to worry about the machine falling and becoming damaged. The sensors slow the machine down using a forward-facing infrared lighting technology to detect change in the floor's surface. These sensors keep the iRobot Roomba from bumping into furniture or walls.

### **Reduces Allergens**

The iRobot Roomba has tangle-free Aero Force extractors to break down dirt and debris from any floor surface. The vacuum uses an airflow accelerator to help seal the machine close to the surface of the floor for a more effective cleaning. Spinning side brushes push debris into the path of the extractors for optimal cleaning. The allergens are trapped inside the HEPA filter, removing them from the air that the consumer breathes. The later model iRobot Roomba offers up to 50 percent more dust and debris removal than earlier models. The 700 series and later provide the most efficient cleaning power to help reduce allergens in the consumer's home.

## Scheduled Cleaning

The Roomba settings are customizable, so a user can schedule cleaning times for each day of the week. Consumers set the iRobot Roomba to clean specific areas and use the infrared virtual walls to block off entrance to off-limit rooms. The vacuum cleans the surface it is set for and, when it is finished, it returns to the docking station or stops where it is when the job is complete. Using the scheduling feature, users never need to encounter the vacuum until it needs emptying.

## Maintenance Free

The iRobot Roomba requires little to no maintenance from the consumer. The vacuum places itself back into the charging station when cleaning is complete and, with the scheduled cleaning settings, it starts tasks automatically. The HEPA filter and dustbin have indicators to let the user know when they need attention. The brushless extractors prevent jams from larger pieces of debris or hair and allow the user to enjoy hassle-free vacuuming without regular maintenance. iRobot Roomba 980 Vacuum Cleaning Robot

If there are looking for a robot vacuum cleaner that offers the latest features and remarkable performance, it's hard to overlook the iRobot Roomba 980. Not only is it the latest addition to the solid iRobot Roomba lineup, but this latest model also boasts features that can't be found on any existing Roomba. Examples include a handy iRobot HOME app that lets they clean and schedule cleaning preferences from their smartphone and an adapt 2.0 Navigation with Visual Localization system that expertly guides the Roomba around the room.

The robot vacuum cleaner is outfitted with a powerful Aero Force Cleaning System with Carpet Boost technology for exceptional cleaning power, particularly on carpets and rugs.



figure 2.6:Roomba 980 robot<sup>[23]</sup>



### **Advantages:**

Powerful Carpet Boost  
technology Precise navigation  
system  
Can be controlled with a smartphone.

### **Disadvantages:**

Expensive  
Battery life could be better  
Occasionally disconnects when using the app.

### **Battery life:**

Battery reliability is a frequently mentioned complaint on customer review websites. Battery replacements from iRobot cost a significant fraction of the purchase price of a new Roomba, though compatible third-party batteries are available at a lower price. The iRobot customer support website offers advice on maximizing battery performance and longevity.

## **2.4 General Objective**

### **Benefits of a Robot Vacuum Cleaner**

Gives someone More Time By Vacuuming For somepeople - This is the best benefit of a robot vacuum as they don't have to constantly invest their time and effort performing the menial chore of vacuuming Their home. By having a robot vacuum it allows they to use that time to do what they want to do. Although this may not initially seem like much, added up over the space of a year or two, just imagine what they would do with all the time they won't be using vacuuming.

Boundaries Can Be Set By Using the Virtual Wall- If They don't want the robot to enter a particular area, just set up the virtual wall, which is a separate piece on the floor which will keep the robot from entering a nominated area. This benefits them when they have children, pets, guests etc. in that room or for simply any other reason they may not want it to enter.

Works on All Types of Floors– Regardless of what floors they have the robot can clean each different type equally. Whether they have timber, tiles, and carpet or floor boards in Their homes. So they don't have to worry about the robot not entering a section of their home because of the particular floor. The robot vacuum is able to work equally on a variety of floors in their home.

**Self-Recharge Battery:** Once the robot is finished cleaning or low on battery it will automatically take itself back to the docking station to charge. This means they won't need to worry about the battery level or have to check when it needs to be recharged. One of the major issues and complaints with robot vacuum cleaner have been their battery life and that they don't last very long. Most batteries on robot vacuum cleaners, even the more expensive models and brand names last between 300 to 500 cycles. This does not last long, especially if they intend to have the robot running several times a week. The better investment for They is to buy a robot which has the new Lithium-ion battery. This is the most rechargeable and energetic batteries available. A robot vacuum container with a lithium-ion battery can last up to 800 cycles.

**Detects All Levels of Dirt with Sensors:** Whether there are small or large spots of dirt the robot will access this and spend more time in a needed area. From dust, hair, nails, paper the robot is able to suck these items up so they don't need to more things.

**Compact & Easy to Store:** They won't have to worry about it taking up some much needed space in the closet. It's slim and sleek design allows the robot to be tucked away under the bed or couch or left on its own in the corner ready for its next set cleaning time.

**Allows Them to Clean Their Home Quicker:** While it cleans the floor they can get started on other areas of their home. Having the robot work with They this way means They can clean Their home

much quicker and easier, gaining more time in Their day and getting to other things They need or want to do much sooner.

**Robots With A UV Sterilization Light Kill Bacteria & Dust Mites :** By not often vacuuming dust mites begin to linger around Their home which can trigger respiratory symptoms and asthma. The robot contains a built in UV – sterilization lamp which means as it vacuums it also uses ultraviolet radiation to kill 96 % of microorganisms, molds, dust mites and fungus which live and breed on their floors by damaging their DNA. This will reduce the risk of respiratory problems and asthma. This means the more the robot is used and the UV light hits their floors it will kill the bacteria and give them a cleaner and more sterile home for They and Their family.

**They Won't Have To Feel Guilty About Not Having Time To Vacuum Their self :** While They worry about everything and everyone else, cleaning Their floors tend to be the last thing on Their mind. While not having the time to complete this menial task the amount of dirt and dust continues to build and become more visible as the week goes on. Then when friends pop over unannounced, they probably just wish that they had some more time to clean up the floors. Rather than have the dirt and dust build up because they are too busy to vacuum, set the robot to clean while they're away and always return home to clean floors.

**Assists People With Mobility Issues:** As they know it is a lot harder and inconvenient for people who suffer with mobility issues as a result of injury and old age to move around, especially constantly vacuum their floors. As a result dirt and dust builds up which can result in respiratory issues. By not being constantly able to clean because of their pain, they also feel the guilt and embarrassment of having unclean floors. By setting up the robot to clean on specific times of the week they will no longer have to experience any pain or discomfort only because they want to vacuum their home. They also have the remote which means they can control the robot from the comfort of their fingertips.

In the past robots have been used to assist us in a variety of practical ways including building cars, high risk situations such as bomb detonators used by the protective forces etc... All the way down to everyday menial and repetitive jobs such as the dishwasher, microwave, washing machine and now the vacuum cleaner. Robots are and will continue to be all around us.

## **Main advantages:**

**Efficiency** Perhaps, efficiency is the main advantage of this technical wonders. After all, even if they like to do cleaning, I do not think they want to vacuum daily, or even many times on day. Soon vacuuming will become an unpleasant and tedious chore. Why wouldn't they want an electric -maidll to do that for They? Why wouldn't they want replace their regular vacuum with this technique gem, especially that has the same functions? A number of add-ons such as filters and brushes are included so shouldn't be worried with not being able to vacuum a specific room.

**Independence** In fact, even its name indicates that a robotic vacuum cleaner works independently, doing all the work automatically and by itself. There is no need for They to do something. Just turn this thing on and let it do its job. It is easy and simple to handle it. Once it is turned on, it will go everywhere through their room, forwards, sideways and backwards. This self-moving vacuum cleaner will not stop until every room in their home is properly vacuumed and cleaned. However, one remark should be made their electric -maidll begins to slow down its work when the battery runs out and it will head to the compartment station. It will do the same in the moment it has finished all the vacuuming.

**Accessibility** Proceeding under Their furniture and appliances is easy and simple due to its flat and circular shape. Because of its smart design the robotic vacuum cleaner can go around and under their stuff pretty easy. In fact, it can go almost anywhere, vacuuming whatever is in front of it. When is in contact with different objects, it has bumpers to keep Their walls and furnishing safe, not to mention that in this way, it can shield itself.

**Detection** This device is equipped with several detectors that can detect dust and dirt, which are then vacuum. May seems unbelievable but this smart vacuum is able to locate the filthiest area of their room and will not stop working until the dirt it is removed. More than that, this device is so smart that keep away from stairs.

**Price** The price of a advanced technological machine seems to be a little expensive. However, it's worth the price and they will be happy with their choice. The price starts from \$250 up to almost \$450, but for this price they will get a top vacuum that will meet their requirements.

## **Purpose of uses**

### **Cleaning takes care of itself:**

Ever find them self-rushing about to vacuum the floor before someone comes over to visit? Do someone get tired of coming home to dirty floors, knowing that they have to vacuum? A robot vacuum cleaner takes care of all of these things for them. Now, they can come home to perfectly clean floors and stop fretting when company is coming.

### **Fewer allergies:**

Because of the fact that a robot vacuum cleans their home constantly and some even come with HEPA filters, their family will breathe cleaner air. Imagine comfortable breathing, less coughing, and less irritation. All of these things are achievable with the help of an automatic vacuum.( High-efficiency particulate arrestance (HEPA) also sometimes called high-efficiency particulate arresting or high- efficiency particulate air, is a type of air filter. Filters meeting the HEPA standard have many applications, including use in medical facilities, automobiles, aircraft and homes. The filter must satisfy certain standards of efficiency such as those set by the United States Department of Energy (DOE). To qualify as HEPA by US government standards, an air filter must remove)

### **Less time cleaning and more time with family and friends:**

Face it vacuuming is a menial task and no one truly enjoys it. When they can automate the process, they have more time to spend with their friends and family, whether their family includes their parents, their children, their husband, their pets – or even a combination of these.

### **Sit back and relax:**

Even if someone lives alone, they still do not want to come home to a dusty, dirty floor. Whether they work 70 hours a week and there are just too tired to clean or their work part-time but choose to wrap them self-up in their hobbies, there is one less task for they to worry about, and all they have to do is relax and enjoy it.

### **A comfortable home that is the apple of their neighbor's eyes:**

Not only will someone notice that their home is cleaner when they invest in a robotic vacuum cleaner, but their friends and family will notice too. They will want to know how they keep everything so clean and they will be able to tell them that it is all thanks to their new automatic vacuum.

### **Bring the future home:**

With so many people standing in line for days on end to purchase the latest Smartphone or video game console, others have discovered a brand new type of technology in the robot vacuum cleaner. What's more, they will not have to wait in line for days to get one. When it arrives, they will marvel in the technology and feel as if they have just leaped into the future.

### **Limitation of cleaning robot:**

The problem of robotic mapping is that of acquiring a spatial model of a robot's environment. Maps are commonly used for robot navigation (e.g., localization). The sensors are subject to errors, often referred to as measurement noise.

More importantly, most robot sensors are subject to strict range limitations. For example, light and sound cannot penetrate walls. These range limitations makes it necessary for a robot to navigate through its environment when building a map.

Robot motion is also subject to errors, and the controls alone are therefore insufficient to determine a robot's pose (location and orientation) relative to its environment. A key challenge in robotic mapping arises from the nature of the measurement noise.

Modeling problems, such as robotic mapping, are usually relatively easy to solve if the noise in different measurements is statistically independent. If this were the case, a robot could simply take more and more measurements to cancel out the effects of the noise.

In robotic mapping, the measurement errors are statistically dependent. This is because errors in control accumulate over time, and they affect the way future sensor measurements are interpreted.

# CHAPTER 3

## System analysis

### 3.1. An overview of fundamental cleaning robots and main Patentees

a fundamental structure of a modern autonomous floor-cleaning robot is complicated, could be illustrated by US6883201 (Fig3.1), which is also a successful product of commercialization today by iRobot Corporation, comprises a housing infrastructure, a motive system with wheels, a bumper, a self- adjusting cleaning head subsystem with brushes and vacuum assembly, a removable dust cartridge, a sensor system to detect obstacles, and a control system for autonomous actions

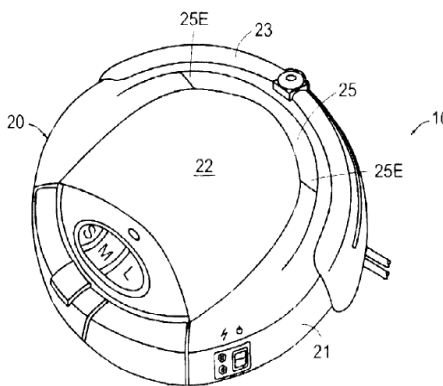

Figure 3.1 a fundamental structure of autonomous floor-cleaning robot.<sup>[46]</sup>

Organized suitable search queries and obtained interested patents, an overview of US granted patents in cleaning robots since 2000 is shown in Figure 3.1

### 3.2 Location recognition and navigation

When a cleaning robot moving on the floor in a room, a blanket movement without any area lost is fundamental requirement. Two major topic for R&D are location recognition and navigation control.



### 3.3 Samsung utilized camera and remote control

Samsung developed a robot capable of recognizing its location and adjusting its direction in response to an obstacle, by a vision camera and a vision board. A series patent started from US6496754 (Fig.3.2), filed 2001, using a vision camera directed toward the ceiling of a room and a vision board, the vision camera recognized a base mark on the ceiling.

After one year, this robot using wireless communications an upwardly-looking camera for photographing an upper image perpendicular to a forward-looking direction of driving the robot cleaner, optional features include second forwardly directed camera to provide a three dimensional image sensors for sensing walls or obstacles and transmission of data to external controllers by a radio antenna.

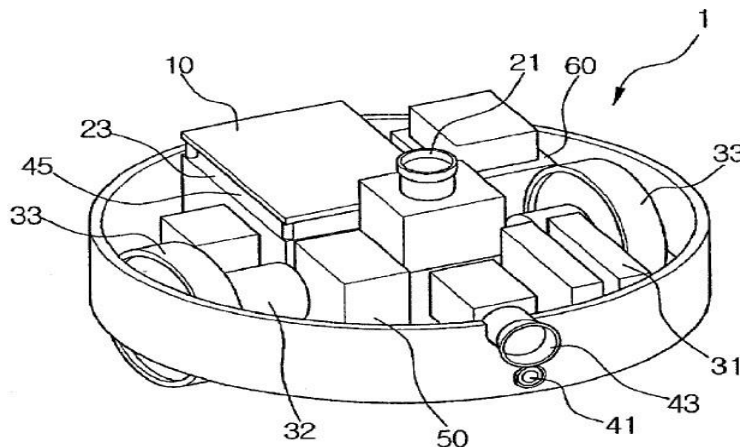

Figure 3.2: A representative figure of US64967<sup>[46]</sup>

### 3.4 iRobot utilized barrier signals as a virtual wall

iRobot was interested in barrier signal dividing the cleaning area, different from camera recognizing location and grip map. The navigation control algorithm can be simplified under the confinement. The basic patent is US6690134, shown in (Fig 3.2), and filed in 2002, includes a portable barrier signal transmitter produces a barrier signal in an infrared frequency, a mobile robot capable of turning in a direction upon detection of the barrier signal.

In 2003, two beams transmitter in 6781338, if operation of the mobile robot causes the reflected portion of the first beam to be blocked such that the signal detector fails to detect the reflected portion of the first beam, the second beam can be detected by the robot detector. US6965209 is similar to \_338, a robot having a propulsion element, a controller, operable to control the propulsion elements and responsive to detection the second beam to control the propulsion elements to move the robot to avoid the second beam.

The transmitter improved further to one or more directed beams, each having a predetermined emission pattern, the receiving subsystem is configured and operative to process the one or more detected directed beams under the control of the navigational control algorithm. US7196487 is a processor recognizes the confinement light beam, the processor controls the motor drive to turn the robot in a direction decided according to gradient levels of the confinement light at different orientations of the robot.

### **3.5 How to develop adjustable brush and air cleaning**

Samsung filed a robot cleaner with adjustable brush in 2003 and granted as US7200892, a pivotal brush prevents overload to a suction motor caused by excessive contact of the brush with the floor surface to be cleaned. US7108731, filed in 2004, is an air cleaning robot, not a floor cleaning one.

This patent basically put an air cleaning part disposed in a robot body, for drawing-in air from an open intake, filtering the atmospheric air, and discharging cleaned air into the atmosphere. US7749294 is also an air cleaning robot, filed in 2006, Samsung put the cyclone structure, could overcome the limited suction efficiency of the small-size suction motor, into a robot cleaner, and separate the dust from the air by centrifugal force. The corner cleaning unit includes a suction member having a suction arm with a rotatable cylinder, a movable member coupled around the rotatable cylinder by a torsion spring such that the movable member can move upwards and downwards together with the suction member.

### 3.6 Cleaning modes and obstacle avoidance

Many obstacles are in a room, walls, cliffs, furniture, electric appliances, miscellaneous articles, etc. The function of obstacle avoidance may decide the value of the whole robot. The dirty situation in a room is always different in different area. Offering many cleaning mode of a robot for users is necessary, this demands need complicated sensors and controlling software.

### 3.7 iRobot constructed complete cleaning mode

IRobot divided cleaning mode into two basic types, one is coverage behaviors, and the other is escape behaviors, and got a series patents, the first is US6809490 the latest granted is US8463438 on June,11,2013.

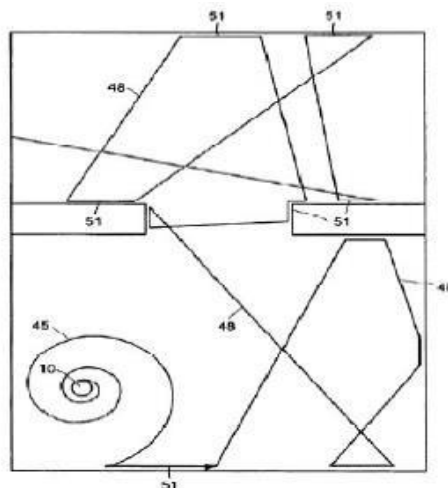

Figure 3.3: cleaning modes in US6809490<sup>[46]</sup>

### 3.8 Problem statement

The goal for an autonomous robot to be able to construct (or use) a map or floor plan and to localize itself in it. Robotic mapping is that branch of one, which deals with the study and application of ability to construct map or floor plan by the autonomous robot and to localize itself in it. It is an intelligent robot because it will itself locate the area which has to be mapped and navigate itself as per predefined algorithm. As everything is automated in nature, the manual efforts are reduced for calculating different parameters for mapping.

# CHAPTER 4

## Design and methodology

### 4.1 Mapping:

A map is a symbolic depiction highlighting relationships between elements of some space, such as objects, region and themes. Robotic mapping is a discipline related to cartography (Cartography is the study and practice of making maps Combining science , and technique, cartography builds on the premise that reality can be modeled in ways that communicate spatial information effectively). The goal for an autonomous robot is to be able to construct (or use) a map or floor plan and to localize itself in it. Robotic mapping is that branch of one, which deals with the study and application of ability to construct map or floor plan by the autonomous robot and to localize itself in it.

### 4.2 Design a mapping circuit

#### STEP 1



INPUT – Room ID, start and map.

MAPPING – Based on the sensor data, the robot will serve the whole room. STORING – Store the data to its memory location.

#### STEP 2



INPUT – Room ID and start.

CLEANING- Start cleaning according to the mapping.

### 4.3 Parts of materials (Table of equipment's)

| SL.NO | Components              | Unit price | Quantity | Total price(In BDT) | Use/purpose              |
|-------|-------------------------|------------|----------|---------------------|--------------------------|
| 1     | Arduino mega 2560       | 1300/=     | 2        | 2600/=              | Microcontroller.         |
| 2     | Continuous servo motor  | 900/=      | 6        | 5400/=              | Controlled rotation      |
| 3     | Booster                 | 300/=      | 3        | 900/=               | Voltage controller       |
| 4     | Servo shield(6 channel) | 1450/=     | 1        | 1450/=              | Servo controller         |
| 5     | Sonar                   | 300/=      | 4        | 1200/=              | Measuring Distance       |
| 6     | Lipo battery            | 3000/=     | 1        | 3000/=              | Voltage supply           |
| 7     | Display                 | 500/=      | 1        | 500/=               | For display              |
| 8     | Body structure          | 7000/=     |          | 7000/=              | Build the body of robot  |
| 9     | Stepper motor           | 950/=      | 1        | 950/=               | Controlling high voltage |
| 10    | Vacuum cleaner          | 2500/=     | 1        | 2500/=              | For cleaning the room    |
| 10    | Miscellaneous           | 2000/=     |          | 2000/=              |                          |

**Total cost = 27500/=BDT**

## 4.4 Circuit Design (mapping)

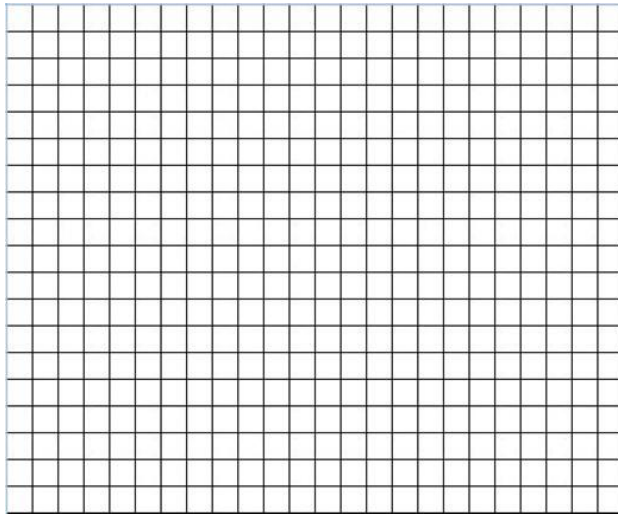

STEP-1

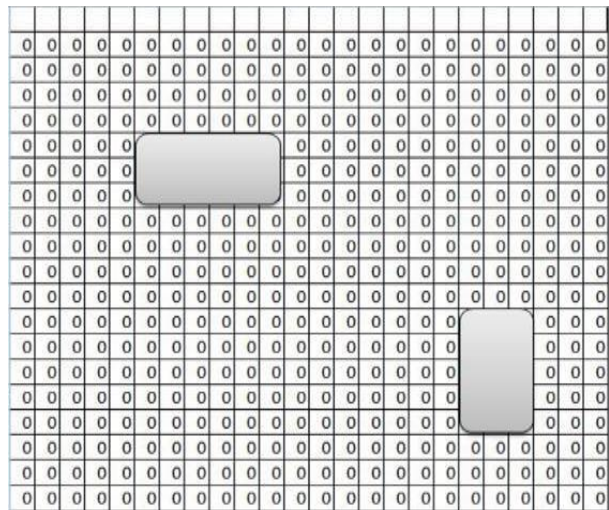

STEP-2

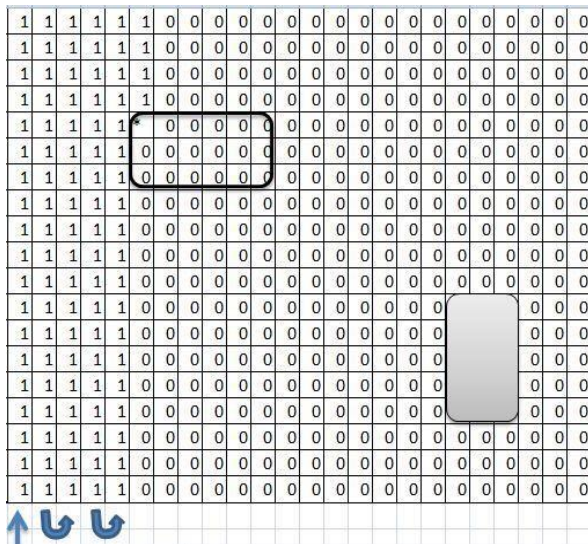

STEP-3

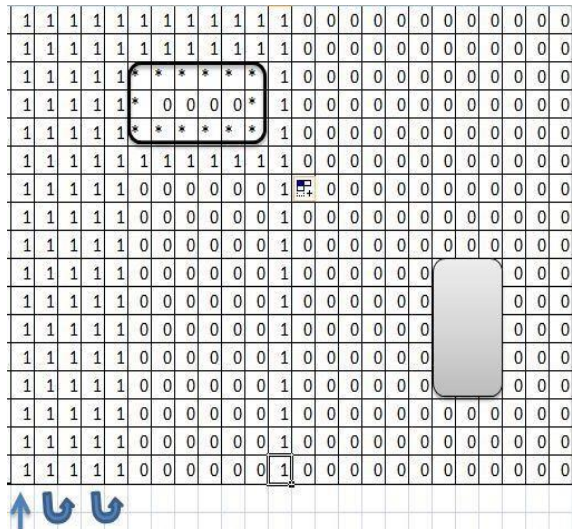

STEP-4

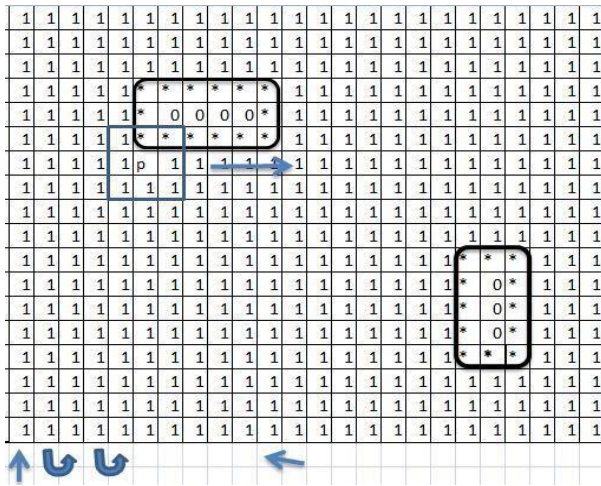

STEP-5

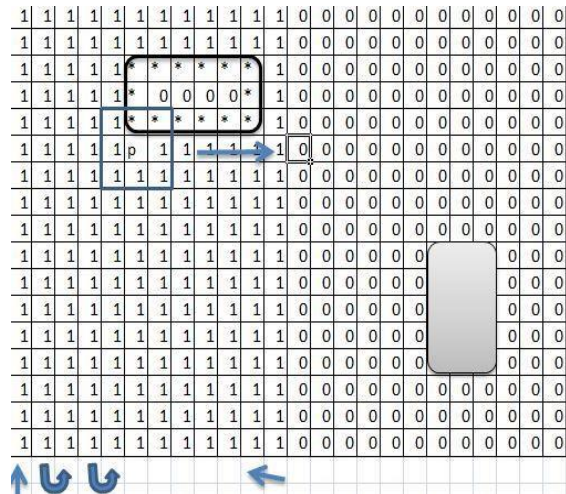

STEP-6

### 4.5 Designed for various obstacles

iRobot invented two obstacle detection modes by emitter in US6594844. One mode having an optical emitter which emits a directed beam having a defined field of emission, and a photon detector having a defined field of view which intersects the field of emission of the emitter at a finite region, detector can detect obstacles in the field of emission, and redirecting the robot to avoid obstacles.

The other mode is wall detection system, includes a housing which navigates with respect to a wall, and a sensor subsystem having a defined relationship with respect to the housing and aimed at the wall for detecting the presence of the wall, and redirects the robot when the wall occupies the region. US7155308 filed in 2003 and followed the first mode, comprising at least two emitters and two photon detectors. US7430455 filed in 2007 and followed the second mode, a circular robot housing, a drive system housed by the robot housing and configured to maneuver the robot with respect to a wall.

# CHAPTER 5

## System Implementation

### 5.1 Mapping Design

#### Map purpose and selection of information

From the very beginning of mapmaking, maps "have been made for some particular purpose or set of purposes". The intent of the map should be illustrated in a manner in which the percipient acknowledges its purpose in a timely fashion. The term percipient refers to the person receiving information and was coined by Robinson. The principle of figure-ground refers to this notion of engaging the user by presenting a clear presentation, leaving no confusion concerning the purpose of the map. This will enhance the user's experience and keep his attention. If the user is unable to identify what is being demonstrated in a reasonable fashion, the map may be regarded as useless.

Making a meaningful map is the ultimate goal. An interesting map will no doubt engage a reader. Information richness or a map that is multivariate shows relationships within the map. Showing several variables allows comparison, which adds to the meaningfulness of the map. This also generates hypothesis and stimulates ideas and perhaps further research. In order to convey the message of the map, the creator must design it in a manner which will aid the reader in the overall understanding of its purpose.

The title of a map may provide the "needed link" necessary for communicating that message, but the overall design of the map fosters the manner in which the reader interprets it.

### 5.2 Map generalization

A good map has to compromise between portraying the items of interest (or themes) in the right place on the map, and the need to show that item using text or a symbol, which take up space on the map and might displace some other item of information. The cartographer is thus constantly making judgments about what to include, what to leave out and what to show in a slightly incorrect place. This issue assumes more importance as the scale of the map gets smaller (i.e. the map shows a larger area) because the information shown on the map takes up more space on the ground.



A good example from the late 1980s was the Ordnance Survey's first digital maps, where the absolute positions of major roads were sometimes a scale distance of hundreds of meters away from ground truth, when shown on digital maps at scales of 1:250,000 and 1:625,000, because of the overriding need to annotate the features.

## **5.3 Robotics design**

### **Defining the Problem**

Identifying the purpose of a construction. Identifying specific requirements. They are confronted with a situation. Here are two examples: A community wants to construct a robot zoo in which the "animals" move their heads, open their mouths and make appropriate sounds when they sense that someone is coming towards them. Design and build a prototype device which could satisfy this need.

A local pet shop wishes to sell a range of devices which automatically feed small cage pets (such as rabbits, gerbils, mice etc.) when their owners are away for the weekend. Design and build a prototype device which could satisfy this need.

They need to determine what problem they are trying to solve before they attempt to design and build a robot to solve a problem. Take the time to study a number of different situations and once they have decided what the situation is and they understand exactly what the problem is then write a design brief in a log book (this will be Their working document as they work on Their robot. This log book can be a paper notebook or an electronic document.) This is a short statement which explains the problem that is to be solved.

### **Researching and Designing**

- Gathering information.
- Identifying specific details of the design which must be satisfied.
- Identifying possible and alternative design solutions.
- Planning and designing a appropriate structure which includes drawings.

Having written a brief, they are now ready to gather information which will help them to produce a successful design. First they will need to decide what information they require. This will be different from project to project and will also depend on the amount of information and knowledge they already have. A useful step will be to use the following chart. Ask the five questions, then read the column headed Gathering Information. This will help them plan the type of information they will need to gather.

## **5.4 Suitable materials for design**

The properties of a material will determine its suitability for a design. For our work with robotics we have chosen to work with Lego. However, there are many different types of materials that can be and are used in the construction of robots Strength, hardness, toughness, density. Durability and the aesthetic qualities determined by color, surface texture, pattern, etc.

## **5.5 Construction methods are appropriate to the design**

Construction techniques fall into the categories of

- Cutting and shaping
- Fabrication - the assembly of the parts using screws, bolts, glues, solder, etc
- Molding - by the application of a force on the material
- Casting - using a mold to form the shape of a solidifying material

A particular material can only be worked in a limited number of ways. The method of construction therefore will be determined by the chosen material, the availability of manufacturing facilities, the skills of the work force and the production costs.

The manufacture, use and disposal of any product will have both beneficial and detrimental effects upon people, wildlife and the environment. The designer therefore, has an enormous responsibility to consider very carefully the potential effects of any new design. This will include: health and safety factors, noise, smell, pollution, etc.

## **5.6 Programming and Testing Robot**

Now it is time to program their robot. This can be achieved in many different ways. Use can achieve rudimentary intelligence in their robot by using only relays, potentiometers, bump switches and some discrete components. They can increase complexity in intelligence in their robot by adding more sensors and continuing in the same vein of using hardwired logic.

By introducing a more sophisticated control element, the microprocessor, they introduce a significant new tool in solving the robot control problem. For our robots we used the RCX Brick that was first developed by Fred Martin at MIT as the Programmable Brick.

## **5.7 Evaluating Their Robot**

1. evaluate the design
2. evaluate the planning process

As building and programming work progresses, and the design begins to take shape, someone will automatically carry out tests on the design. any person can also need to complete systems tests at various stages of the construction. If any of the tests show that they have failure in a joint, or that part of their structure is not meeting specifications, then they will have to make modifications in their plan.

When building and programming is complete, the entire project must be tested to see if it does the job for which it was designed. An evaluation needs to then be written. This should be a statement outlining the strengths and weaknesses in their design. It should describe where they have succeeded and where they have failed to achieve the aims set out in the specifications.

## 5.8 iRobot used emitter to come home

US7332890, filed in 2004, is a method for energy management in a robotic device includes providing a base station for mating with the robotic device, determining a quantity of energy stored in an energy storage unit of the robotic device, and performing a predetermined task based at least in part on the quantity of energy stored.

Also disclosed are systems for emitting avoidance signals to prevent inadvertent contact between the robot and the base station, and systems for emitting homing signals to allow the robotic device to accurately dock with the base station. Management can reduce recharging times

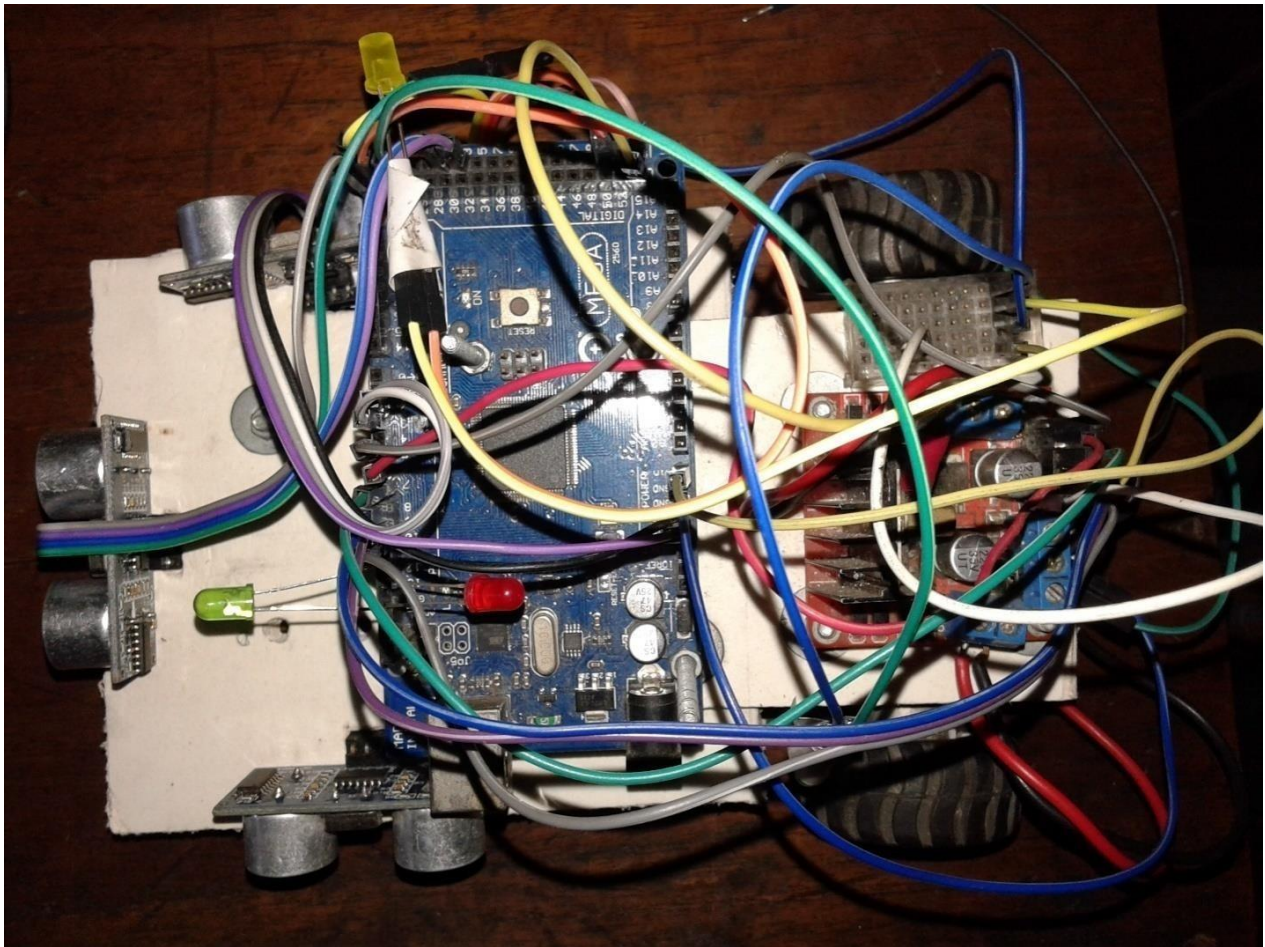

Figure5.1: final robot

## CHAPTER 6

### Conclusion

Finally we built a robot successfully. Our goal was the robot will map the room and it will start clean the room automatically. But we can't do it properly because of some problems. But according to our performance the robot can run and it can identify any obstacle in the room and it can move any side according to programming code properly.

Such this type of robot, if it could perform its duties safely and reliably, would be of immense value to any rescue operation. The robot prototype designed and built for this major qualifying project was meant to be a starting point for such a robot; due to time and budget constraints building a fully functional search and rescue robot was not feasible. By designing and building the autonomous mapping robot many steps were taken towards the design of a fully functional search and rescue robot.

Our robot performed generally quite well, it found the Pringles tubes quickly and if it didn't quite get a proper grip on them with the claws it backed away and tried again. We even tested it in different sized arenas and it still worked reliably, although due to the robot finding the tubes quite randomly (our "searching" involved moving forwards a little bit, spinning round to see if it senses a tube and then moving forward again if it doesn't) it worked much more quickly and impressively in smaller arenas (this also helped with our lack of moving in a straight line!). The robot did turn out to be incredibly reliable, once we had uploaded the final code it always put the tubes in the correct end-zones.

Although we ripped apart the robot completely several times and rebuilt it just in an attempt to solve little problems (most often the driving in a straight line problem) the final structure of the robot was definitely the most robust design. The object or wall avoidance worked well the majority of the time and came into use quite a lot as the robot seemed to travel in a much less straight line than usual on the actual demonstration day. It did struggle though when it found itself a corner as the IR sensor turns the robot always away from the closest wall. This meant that in a corner it moved away from the left hand wall towards the right hand wall, it now turns away from the right hand wall towards the left hand wall, etc. We did have code to recognize when the robot was in a corner but it seemed to sometimes take a while to get the robot out of the corner.

## REFERENCES

1. Robert Kunzig (May 1999). "A Tale of two obsessed archeologists, one ancient city, and nagging doubts about whether science can ever hope to reveal the past". Discover Magazine.
2. Stephanie Meece (2006). "A bird's eye view – of a leopard's spots. The Çatalhöyük 'map' and the development of cartographic representation in prehistory". *Anatolian Studies*. 56: 1–16. JSTOR 20065543.
3. Bicknell, Clarence (1913). *A Guide to the prehistoric Engravings in the Italian Maritime Alps, Bordighera*.
4. Delano Smith, Catherine (1987). *Cartography in the Prehistoric Period in the Old World: Europe, the Middle East, and North Africa*. In: Harley J.B., Woodward D. (eds.), *The History of Cartography: Cartography in Prehistoric, Ancient and Mediaeval Europe and the Mediterranean* v. 1, Chicago: 54-101 online, retrieved December 2, 2014.
5. Arcà, Andrea (2004). The topographic engravings of the Alpine rock-art: fields, settlements and agricultural landscapes. In Chippindale C., Nash G. (eds.) *The figured landscapes of Rock-Art*, Cambridge University Press, pp. 318-349; online academia.edu, retrieved December 2, 2014. Uchicago.edu the Nippur Expedition.
6. A. Raaflaub; Richard J. A. Talbert (2009). *Geography and Ethnography: Perceptions of the World in Pre-Modern Societies*. John Wiley & Sons. p. 147. ISBN 1-4051-9146-5.
7. Catherine Delano Smith (1996). "Imago Mundi's Logo the Babylonian Map of the World". *Imago Mundi*. 48: 209–211. Doi: 10.1080/03085699608592846. JSTOR 1151277.
8. Finel, Irving (1995). "A join to the map of the world: A notable discovery". *British Museum Magazine*. 23: 26–27.
9. "History of Cartography". Archived from the original on 2009-10-31..J. L. Berggren, Alexander Jones; *Ptolemy's Geography By Ptolemy*, Princeton University Press, 2001 ISBN 0-691-092591
10. Miyajima, Kazuhiko (1997). "Projection methods in Chinese, Korean and Japanese star maps". In Johannes Andersen. *Highlights of Astronomy*. 11B. Norwell: Kluwer Academic Publishers. p. 714. ISBN 978-0-7923-5556-4.

11. Needham, Joseph (1971). Part 3: Civil Engineering and Nautics. Science and Civilization in China. 4. Cambridge University Press. p. 569. ISBN 978-0-521-07060-7.
12. Studies in the Geography of Ancient and Medieval India. Motilal Banarsidass Publishers. p. 330. ISBN 81-208-0690-5.
13. Woodward, p. 286[citation needed] S. P. Scott (1904), History of the Moorish Empire, pp. 461– 462.
14. Globes and Terrain Models – Geography and Maps: An Illustrated Guide, Library of Congress" Map Imitation" in Detecting the Truth: Fakes, Forgeries and Trickery, a virtual museum exhibition at Library and Archives Canada "Deconstructing the Map". Cartographica, Vol. 26, No. 2. pp 1-5 Michel Foucault, The Order of Things: An Archaeology of the Human Sciences.
15. A Translation of Les mots choses. New York: Vintage Books, 1973. Stone, Jeffrey C. (1988). "Imperialism, Colonialism and Cartography". Transactions of the Institute of British Geographers, N.S.
16. "Cartography and Empire Building in the Nineteenth-Century West Africa". Geographical Review, Vol. 84, No. 3. P-316.
17. Monmonier, Mark (2004). Rhumb Lines and Map Wars: A Social History of the Mercator Projection p. 152. Chicago: The University of Chicago Press. (Thorough treatment of the social history of the Mercator projection and Gall–Peters projections.)
18. Jeong, Seonkoo, Yoon, Byungun(2013), A Systemic Approach to Exploring an Essential Patent Linking Standard and Patent Maps: Application of Generative Topographic Mapping(GTM), Engineering Management Journal, 25(1),48-57.
19. Joo, Si Hyung, Lee, Keun(2010), Samsung’s catch-up with Sony: an analysis using US patent data. Journal of the Asia Pacific Economy, 15(3), 271-287.
20. European International Journal of Science and Technology ISSN: 2304-9693
21. Narin, F.(1995), Patent as indicators for the evaluation of industrial research output. Scientometrics, 34(3),489-496.
22. Schneider, Cédric(2011), A comparative analysis using patent citations data. Applied Economics Letters, 18, 865-871.
23. Son, Changho, Yongyoon Suh, Jeonghwan Jeon, and Yongtae Park(2012), Development of a GTM-based Patent Map for Identifying Patent Vacuums, Expert Systems with

Applications, 39(3), 2489-2500.

24. Yoon, Byung-Un, Yoon, Chang-Byung, and Part, Yong-Tae(2002), On the development and application of a self-organizing feature map-based patent map. *R&D management*, 32(4), 291- 300.
25. Science News, 2004.10.21. [Online]Available.
26. Fahy, Frank (1998). *Fundamentals of noise and vibration*. John Gerard Walker. Taylor & Francis. p. 375. ISBN 0-419-24180-9.
27. Hill, M. N. (1962). *Physical Oceanography*. Allan R. Robinson. Harvard University Press. p. 498.
28. Seitz, Frederick (1999). *The cosmic inventor: Reginald Aubrey Fessenden (1866-1932)*. 89. American Philosophical Society. pp. 41–46. ISBN 0-87169-896-X.
29. Hendrick, Burton J. (August 1914). "Wireless Under The Water: A Remarkable Device That Enables A Ship's Captain To Determine The Exact Location Of Another Ship Even In The Densest Fog". *The World's Work: A History of Our Time*. XLIV (2): 431–434. Retrieved 2009- 08-04.
30. "Report of Captain J.H. Quinan of the U.S.R.C Miami on the Echo Fringe Method of Detecting Icebergs and Taking Continuous Soundings". *Hydrographic Office Bulletin*. U.S. Coast and Geodetic Survey. 1914-05-13. (quoted in a NOAA transcript by Central Library staff April, 2002.
31. "World War II Naval Dictionary". USS Abbot (DD-629). Retrieved February 19, 2014.
32. W Hackmann, *Seek & Strike: Sonar, anti-submarine warfare and the Royal Navy 1914-54* (HMSO, London, 1984)
33. Lent, K (2002). "Very High Resolution Imaging Diver Held Sonar". Report to the Office of Naval Research. Retrieved 2008-08-11.
34. Krueger, Kenneth L. (2003-05-05). "Diver Charting and Graphical Display". Texas Univ at Austin Applied Research Labs. Retrieved 2009-01-21.
35. "This Suit Gives You A Real Life Spider-Sense". *Forbes*. 23 February 2013. Retrieved 12 March 2013.
36. H O Berkta, *Some Finite Amplitude Effects in Underwater Acoustics* in V M Albers "Underwater Acoustics" 1967
37. A b Damian Carrington (3 July 2013). "Whales flee from military sonar leading to mass



strandings, research shows".

38. Cho Youngjun (2014). "US patent: Electronic device having proximity touch function and control method thereof".
39. Cho, Youngjun (2016). "US patent: Vehicle Display Apparatus".
40. Cho, Youngjun (2015). "US patent: DISPLAY APPARATUS FOR A VEHICLE".
41. Sketchbook for Light Sensor
42. Eagle File for Grove - Light Sensor V1.0
43. Eagle File for Grove - Light Sensor(P) V1.0
44. Eagle File for Grove - Light Sensor(P) V1.1
45. "Principal Investigator: W. Kennedy", National Institutes of Health, NIH SBIR 2 R44 HD041781-02
46. "Speci-Minder; see elevator and door access" Archived January 2, 2008, at the Wayback Machin
47. Bergin, Chris (2014-11-18). "Pad 39A – SpaceX laying the groundwork for Falcon Heavy debut". NASA Spaceflight. Retrieved 2014-11-17.
48. Digital Domain Projects, "I, Robot". Digitaldomain.com. Retrieved 2013-08-23.
49. A b "Jeff Vintar was Hardwired for I,Robot". screenwritersutopia. Retrieved 2015-05-27.
50. I, robot – Movie Review. Motor Trend. Retrieved on 2011-06-21.

# APPENDIX - I

## Programming code

How to write a program in arduino ?

Example: Write a code to control a LED (on and off after 1 second) ?

Ans: Sketch to Blink Two LED's using

```
Arduino const int LED1 = 12;
```

```
const int
```

```
LED2 = 13;
```

```
void setup()
```

```
{
```

```
  pinMode(LED1,OUTPUT);
```

```
  pinMode(LED2,OUTPUT);
```

```
}
```

```
void loop()
```

```
{
```

```
  digitalWrite(LED1,HIGH);
```

```
  delay(1000);
```

```
  digitalWrite(LED1,LOW);
```

```
  digitalWrite(LED2,HIGH);
```

```
  delay(1000);
```

```
  digitalWrite(LED2,LOW);
```

```
}
```

The only difference in this sketch is use of 2 pins in output mode. I have used pin number 12 and 13 as output. I have configured them as output inside the setup() function. Inside the loop(), I have written commands to blink LED's alternatively. When LED1 is ON, LED2 will be OFF. After 1 second LED1 will turn OFF and at the same time LED2 will turn ON. Wait another 1 second and they will see LED2 turning OFF and LED1 turning ON. This cycle repeats.

## 2.Control LED with Push Button

```
const int LED = 13;

const int SW = 7;

int val=0;

void setup()

{

  pinMode(LED,OUTPUT);

  pinMode(SW, INPUT);

}

void loop()

{

  val=digitalRead(SW);

  if(val==HIGH)

  {

    digitalWrite(LED,HIGH);

  }

  else

  {

    digitalWrite(LED,LOW);

  }}
```

### **Our main programming code for our room mapping robot:**

```
#define spd 130

#define tspd 200

#define ntspd -100

#define turnDelay 650

#define trigP 2
```

```
#define echoP 3

#define trigL 53

#define echoL 51

#define trigF 33

#define echoF 31

#define trigR 30

#define echoR 32

#define rightMotorPWM 5

#define rightMotor1 6

#define rightMotor2 7

#define leftMotor1 9

#define leftMotor2 8

#define leftMotorPWM 10

#define ll 24

#define rr 22

void setup()

{

    // 9600 is band speed

    Serial.begin(9600);

    // input outpu mode selct

    pinMode(rightMotorPWM, OUTPUT);

    pinMode(rightMotor1, OUTPUT);

    pinMode(rightMotor2, OUTPUT);

    pinMode(leftMotor1, OUTPUT);

    pinMode(leftMotor2, OUTPUT);

    pinMode(leftMotorPWM, OUTPUT);

    pinMode(trigL, OUTPUT);

    pinMode(echoL, INPUT);
```

```

pinMode(trigF, OUTPUT);
pinMode(echoF, INPUT);
pinMode(trigP, OUTPUT);
pinMode(echoP, INPUT);
// front and back
pinMode(12, OUTPUT);
pinMode(11, OUTPUT);
// right LED
pinMode(rr, OUTPUT);
// left LED
pinMode(ll, OUTPUT);
}
// all zero means there is an obstacle in front of it
short ls = 0, rs = 0, fs = 0, bs = 0;
// this function runs continuously
void loop()
{
// motor(speed,-speed);
// sF();
//Serial.println(sR());
base();
//delay(100);
}
void base() {
// checks the obstacle on different sides
check();
// front is open
if ( fs == 1 )

```

```

{
// led front

digitalWrite(11, 1);

motor(sp1, spd);

digitalWrite(11, 0);
}

// front left right is blocked

else if ( fs == 0 && ls == 0 && rs == 0)

{

digitalWrite(12, 1);

digitalWrite(11, 1);

backward();

// forward();

digitalWrite(11, 0);

digitalWrite(12, 0);

}

// front and left block

else if ( fs == 0 && ls == 0) {

rightUTurn();

}

// front and right block

else if ( fs == 0 && rs == 0) {

leftUTurn();

}

else if(fs == 0)

{

```

```

    uTurn();
}
else if( rs == 0)
{
    motor(0, 250);
}
else if( ls == 0)
{
    motor(250, 0);
}

}

//===== check @ which obstacle is
void check()
{
    int ldist = sL();
    int fdist = sF();
    int rdist = sR();

    if ( ldist < 10)ls = 0;
    else ls = 1;
    if ( rdist < 10)rs = 0;
    else rs = 1;
    if ( fdist < 10)fs = 0;
    else fs = 1;
    // Serial.print(ls);
    // Serial.print(fs);

```

```
// Serial.println(rs);  
}  
//----- turns
```

```
void leftTurn()  
{  
    digitalWrite(ll, 1);  
    motor(ntspd, tspd);  
    delay(turnDelay);  
    digitalWrite(ll, 0);  
}
```

```
void rightTurn()  
{  
    digitalWrite(rr, 1);  
    motor(tspd, ntspd);  
    delay(turnDelay);  
    digitalWrite(rr, 0);  
}
```

```
int dir = 0;
```

```
void uTurn()
```

```
{  
    if (dir == 1)  
    {  
        leftTurn();  
        leftTurn();  
        dir = 0;  
    }  
}
```



```

else
{
    rightTurn();
    rightTurn();
    dir = 1;
}
}

void leftUTurn()
{
    leftTurn();
    leftTurn();
}

void rightUTurn()
{
    rightTurn();
    rightTurn();
}

void forward()
{
    motor(sp, spd);
    delay(100);
}

void backward()
{
    motor((-1)*spd, (-1)*spd);
    delay(100);
}

//===== SONARLeft

```

```

int sL()
{
  Serial.print("left ");
  return sonar(trigL, echoL);
}

//===================================================== SONARRight

int sR() {
  long duration;
  long distance;
  digitalWrite(trigP, LOW); // Added this line
  delayMicroseconds(2); // Added this line
  digitalWrite(trigP, HIGH);
  // delayMicroseconds(1000); - Removed this line
  delayMicroseconds(10); // Added this line
  digitalWrite(trigP, LOW);
  duration = pulseIn(echoP, HIGH);
  distance = (duration / 2) / 29.1;

  if (distance >= 250 || distance <= 0) {
    Serial.println("Out of range");
  }
  else {
    Serial.print("right ");
    Serial.print(distance);
    Serial.println(" cm ");
  }
  if (distance == 0) return 100;
  return distance;
}

```

```

}

//===================================================== SONARFront

int sF()

{ Serial.print("front ");

  return sonar(trigF, echoF);

}

//===================================================== SONAR

int sonar(int trigPin, int echoPin)

{

  int duration;

  int distance;

  digitalWrite(trigPin, LOW); // Added this line

  delayMicroseconds(2); // Added this line

  digitalWrite(trigPin, HIGH);

  // delayMicroseconds(1000); - Removed this line

  delayMicroseconds(10); // Added this line

  digitalWrite(trigPin, LOW);

  duration = pulseIn(echoPin, HIGH);

  distance = (duration / 2) / 29.1;

  if (distance >= 250 || distance <= 0) {

    Serial.println("Out of range");

  }

  else {

    Serial.print(distance);

    Serial.print(" cm ");

  }

  if (distance == 0) return 100;

```

```

return distance

// BOTH MOTOR

void motor(int LS, int RS)

{

if (LS >= 0)motorL( 1, 0, LS);    //forward
else motorL( 0, 1, (-1)*LS);    //backward

if (RS >= 0)motorR( 1, 0, RS);    //forward
else motorR( 0, 1, (-1)*RS);    //backward
}

////////////////////////////////////right motor
void motorR(int ina, int inb, int mspeed)

{

digitalWrite(rightMotor1, ina);
digitalWrite(rightMotor2, inb);
analogWrite(rightMotorPWM, mspeed);
}

////////////////////////////////////Left motor
void motorL(int ina, int inb, int mspeed)

{

digitalWrite(leftMotor1, ina);
digitalWrite(leftMotor2, inb);
analogWrite(leftMotorPWM, mspeed);
}

```