

DESIGN AND IMPLEMENTATION OF AN AERIAL SURVEILLANCE UNIT USING WIRELESS COMMUNICATION SCHEME

A dissertation submitted in partial fulfillment of requirement for the degree of Bachelor of Science in Engineering in Electrical and Electronic Engineering.

Islamic University of Technology (IUT)

The Organisation of Islamic Cooperation (OIC)



SUBMITTED BY

RIASAT SIAM ISLAM (STUDENT ID: 082421)

NAFIS HUSSAIN (STUDENT ID: 082434)

ISMAIL BIN IBRAHIM (STUDENT ID: 082447)

UNDER THE SUPERVISION OF

GOLAM SAROWAR

ASSISTANT PROFESSOR

DEPARTMENT OF ELECTRICAL AND ELECTRONIC ENGINEERING

ISLAMIC UNIVERSITY OF TECHNOLOGY, BANGLADESH

**DESIGN AND IMPLEMENTATION OF AN AERIAL
SURVEILLANCE UNIT USING WIRELESS
COMMUNICATION SCHEME**

A Thesis Presented to

The Academic Faculty

By

RIASAT SIAM ISLAM (STUDENT ID: 082421)

NAFIS HUSSAIN (STUDENT ID: 082434)

ISMAIL BIN IBRAHIM (STUDENT ID: 082447)

In partial fulfillment of requirement for the degree of Bachelor of Science in
Engineering

In

Electrical and Electronic Engineering

Islamic University of Technology (IUT)

October, 2012

DESIGN AND IMPLEMENTATION OF AN AERIAL
SURVEILLANCE UNIT USING WIRELESS
COMMUNICATION SCHEME

Approved By:

GOLAM SAROWAR

ASSISTANT PROFESSOR

DEPARTMENT OF ELECTRICAL AND ELECTRONIC ENGINEERING

ISLAMIC UNIVERSITY OF TECHNOLOGY, BANGLADESH

Date Approved: 6 October, 2012

DESIGN AND IMPLEMENTATION OF AN AERIAL SURVEILLANCE UNIT USING WIRELESS COMMUNICATION SCHEME

Abstract:

In recent times, a wide variety of applications for Aerial Surveillance are being introduced. This project has been aimed to design and implement an Aerial Surveillance Unit that will be used for further research on applications of Aerial Surveillance to traffic management, crime management, pollution control, protection and security. The preliminary prototype will consist of a camera device that will provide live video feed at the remote end and the complete system will be teleoperated. The main control system consists of ATmega2560, for the surveillance system we have used a low power serial camera, the secured communication system consists of a Wi-Fi router connected to Arduino Ethernet Shield, the flight mechanism is accomplished using a high rpm bldc motor and servo motors has been used to control lift, yaw and landing. The surveillance mechanism had worked successfully receiving video at 640x 480 and 320x 240 resolutions. Since, it is a preliminary device there is definite scope for further development to design an Aerial Surveillance Unit for the desired purpose.

Acknowledgements

All praises due to Allah, the Almighty, that He has enabled us to accomplish this task.

We would like to thank our project supervisor Assistant Professor Golam Sarowar, for his constant support and encouragement in pursuing such a challenging project. He has provided us the right balance of guidance and independence in our work. His experience and vast knowledge in the related field has given us an endeavor to research the depths of the individual topics which has been reflected in our work immensely.

We would also like to thank the lab attendants for their relentless help and support. Especially, we are highly indebted to Kabir bhai of Electronics Lab. Again valuable advice from many lecturers of our department signifying the value of a good project work accelerated our working speed and dedication in the project. We are highly thankful to Mushfiqul Alam, University of Liverpool for his ideas and help with the aeronautics. Also, we would like to thank our younger brother Adib Bin Rashid, Student ID: 091432 for the CAD design. We are truly grateful for their effort and time.

Lastly, special thanks go to our family and friends for being with us all the time in our hardship and pains and being such great well-wishers.

Contents

LIST OF TABLES.....	4
LIST OF FIGURES	5
INTRODUCTION.....	7
CHAPTER 1 - COMPARATIVE ANALYSIS.....	9
1.1 SURVEILLANCE SYSTEM.....	9
1.1.1 CMU CAM.....	9
1.1.2 AVR CAM.....	10
1.1.3 IP CAMERA.....	12
1.1.4 SERIAL CAMERA.....	13
1.2 COMMUNICATION SYSTEM	22
1.2.1 WIMAX.....	22
1.2.2 XBEE.....	23
1.2.3 RF.....	24
1.2.4 BLUETOOTH.....	24
1.2.5 WIFI.....	25
CHAPTER 2 – SYSTEM OVERVIEW	28
2.1 CAD DESIGN AND CONSTRUCTION.....	28
2.2 MAIN CONTROL SYSTEM.....	30
2.3 POWER SUPPLY	34
2.4 SURVEILLANCE SYSTEM.....	35
2.5 COMMUNICATION SYSTEM	37
2.5.1 ARDUINO ETHERNET SHIELD.....	38
2.5.2 TP LINK ROUTER.....	40
2.6 LOCOMOTION SYSTEM.....	41
2.6.1 SERVO MOTOR.....	41
2.6.2 BLDC MOTOR.....	45
CHAPTER 3 - SYSTEM CONNECTIVITY AND OPERATION.....	54
3.1 CONNECTIVITY	54
3.2 OPERATION.....	58
CHAPTER 4 - SOFTWARE AND PROGRAMMING.....	59
4.1 SOFTWARES USED.....	59
4.2 PROGRAM PSEUDO CODE.....	59
4.3 FLOWCHART.....	61
TROUBLESHOOTING	62
FURTHER WORK	62
CONCLUSION.....	62
APPENDIX A: PIN MAPPING FOR ARDUINO MEGA 2560	64
APPENDIX B: TL-WR340GD SPECIFICATIONS.....	68
REFERENCES.....	69

LIST OF TABLES

Table 1.1: Protocol Diagram	14
Table 1.2: Specifications	14
Table 1.3: Pin Definition and Rating	14
Table 2.1: Summary of Specifications	31
Table 2.2: Maximum Current Drawn By Each Component.....	34
Table 2.3: Specificaitons For TowerPro MG995	44
Table A.1: Pin Mapping for Arduino Mega 2560.....	67
Table B.1: Hardware Features	68
Table B.2: Wireless Features	68
Table B.3: Software Features	68

LIST OF FIGURES

Figure 1.1: CMUcam.....	9
Figure 1.2: AVRcam Front View.....	10
Figure 1.3: AVRcam Rear View.....	11
Figure 1.4: IP Camera.....	12
Figure 1.5: Grove Serial Camera.....	13
Figure 1.6: Block Diagram for Camera.....	14
Figure 1.7: UART Timing Diagram.....	15
Figure 1.8: uCam.....	15
Figure 1.9: Pin Configuration.....	16
Figure 1.10: Pin Description.....	16
Figure 1.11: Single Byte Timing Diagram.....	17
Figure 1.12: Command Sequence Timing Diagram.....	17
Figure 1.13: Command Set.....	18
Figure 1.14: Operating Conditions.....	21
Figure 1.15: Ratings.....	21
Figure 1.16: Optical Characteristics.....	22
Figure 2.1: System Block Diagram.....	28
Figure 2.2: Side View.....	28
Figure 2.3: Front View.....	29
Figure 2.4: Top View.....	29
Figure 2.5: Aerial Surveillance Unit.....	30
Figure 2.6: Arduino Mega 2560 Front View.....	31
Figure 2.7: Li-Poly Battery.....	34
Figure 2.8: Current Supplied vs Time Graph.....	34
Figure 2.9: uCam-232 Connection Diagram.....	35
Figure 2.10: MAX232 IC.....	35
Figure 2.11: Synchronizing uCam.....	36
Figure 2.12: JPEG Image Capture.....	36
Figure 2.13: Process For Live Video.....	37
Figure 2.14: General Block Diagram for Communication Scheme.....	37
Figure 2.15: Arduino Ethernet Shield.....	38
Figure 2.16: TP Link Router, TL-WR340GD.....	40
Figure 2.17: Pulse Width and Corresponding Angle.....	42
Figure 2.18: Servo Gears.....	42
Figure 2.19: Servo Control Circuitry.....	43
Figure 2.20: TowerPro MG995.....	44
Figure 2.21: Brushless DC Motor Parts.....	45
Figure 2.22: Block Diagram For BLDC Motor.....	45
Figure 2.23: Comparison Between Conventional and Brushless Motors.....	46
Figure 2.24: Three-Phase Unipolar Brushless DC Motor.....	47
Figure 2.25: Switching Sequence and Rotation of Stator's Magnetic Field.....	48
Figure 2.26: Three Phase Bipolar-Driven Brushless Motor.....	49
Figure 2.27: Stator's Magnetic Field in the Shutter State and Torque Direction.....	49
Figure 2.28: Clockwise Revolutions of the Stator's Magnetic Field and Rotor.....	50
Figure 2.29: Counter Clockwise Revolutions of the Stator's Magnetic Field and Rotor.....	50
Figure 2.30: T- ω Curve of a Brushless DC Motor with a Constant Voltage Supply.....	51
Figure 2.31: Electronic Speed Controller for a BLDC Motor.....	51

Figure 2.32: BLDC Motor with ESC, D2822/14 1450Kv	52
Figure 2.33: HQ 848A Propeller Blade	53
Figure 3.1: Simplified Connection Diagram	54
Figure 3.2: Schematic Diagram.....	55
Figure 3.3: PCB Layout.....	56
Figure 3.4: 3D Visualization For PCB Layout.....	57
Figure 3.5: Testing with Arduino Board and Ethernet Shield using Fritzing	58
Figure 3.6: Screenshot for Web Based GUI.....	58
Figure A.1: Pin Diagram for Arduino Mega 2560	64

INTRODUCTION

Surveillance is the monitoring of the behavior, activities, or other changing information, usually of people for the purpose of influencing, managing, directing, or protecting. There are many types of surveillance but we are mainly focused on surveillance via air i.e. Aerial Surveillance.

Aerial Surveillance is the gathering of video or imagery information via an aerial transport like helicopter or spy plane. Developments in digital imaging technology, miniaturized computers over the past decade have made significant contribution to the improvement of aerial surveillance hardware such as micro-aerial vehicles, forward-looking infrared and high-resolution imagery capable of identifying objects at extremely long distances.

An Aerial Surveillance Unit has no onboard human pilots. To accomplish a successful operation, a high amount of human involvement is required. Typically a launch crew (1-3 people), a mission crew consisting of 2-5 people, intelligence analysts and many others are required to operate the vehicle.

To maintain social control, recognize or monitor threats, and prevent or investigate criminal activity, government and law enforcement agencies uses surveillance as one of their defense measures. Technologies such as high speed surveillance computers and biometric software have given government unprecedented ability to monitor the activities of their subjects.

Aerial Surveillance Units can be used to patrol the skies for the purposes of critical infrastructure protection, border patrol, "transit monitoring", and general surveillance of a country's population. With an upgrade of facial recognition program they can track and detect suspicious people. Since with minimum resources they can cover a wider radius hence get a better view of the surrounding, they are used for different police tactical operation as well as for traffic control.

Aerial Surveillance Units can range from micro-aerial vehicles to full-size drones. Apart from doing surveillance, MAV are also equipped with tasers or small weapons. The tasers are used for crowd control where as the weapons are used for killing enemy combatants.

During reconnaissance missions, aerial surveillance units help to reduce the number of casualties when it flies into a hostile zone as there are no human pilots on board. Apart from reducing human casualties, it can also save lives by locating the position of people in distress such as inside a burning building.

Programs such as the Heterogeneous Aerial Reconnaissance Team program developed by DARPA have automated much of the aerial surveillance process. The program allows the system to automatically pilot large team of drones, automatically detect suspicious characters and decides the necessary actions that need to be undertaken. Thus a city can be patrolled and suspicious individual can be tracked with the help of automated, self-directing drones which report their activities to a centralized monitoring station.

The main objective for this project is line with the university's new research incentives. Throughout the world, research on Aerial Surveillance is going on full throttle. The military and non-military applications are vast as a result Islamic University of Technology has taken the initiative to pursue research in this particular field, among others. This project is the building block or the stepping stone for further research. In the upcoming years, students will continue working with this project giving it a proper shape. Moreover, this is the very first time such research activities are being conducted in the University level. There are already a wide variety of applications of Aerial Surveillance. Its prospects are numerous.

Some of the applications are mentioned below:

- Public event surveillance and observation
- Disaster Related

- Evacuation coordination
- Search and Rescue
- Emergency management on-demand network (FireTide node)
- Traffic Management
- Border Security
- Facility and Asset Protection
- Energy infrastructure
- Conventional power plants
- Nuclear power plants
- Oil refineries
- Tanks and storage
- Sea Ports
- Rail depots
- Embassy protection
- Climate Prediction
- Pollution Management
- Conservation of Wildlife
- Oil, gas and minerals exploration
- Agriculture
- Crime Scene Investigation
- Crime management

The following chapters describe more details about the project. Chapter1 gives an overview on the available options or methods to implement an Aerial Surveillance System. It focuses on a comparative study of all the possible methods to implement the subsystems and why we have a chose a certain component for usage. Chapter 2 describes the system that we have implemented, starting from the theory, concepts, design features, description of each subsystem and its components. Chapter 3 states the method for circuit implementation, the hardware connections and how the system operates. Chapter 4 briefly mentions the softwares used and the programming. Chapter 5 discusses the problems that we have faced while implementing the Aerial Surveillance Unit and their remedies. Chapter 6 outlines the possible improvements that can be made to the system.

CHAPTER 1 - COMPARATIVE ANALYSIS

In order to design a low cost Aerial Surveillance Unit it is required to implement low power surveillance and communication system.

1.1 SURVEILLANCE SYSTEM

This chapter focuses on the different surveillance mechanism that can be implemented for a low cost – low power surveillance system. It is to be noted that, we have used a serial JPEG camera module from 4D Systems Pty. Ltd, Australia.

1.1.1 CMU CAM

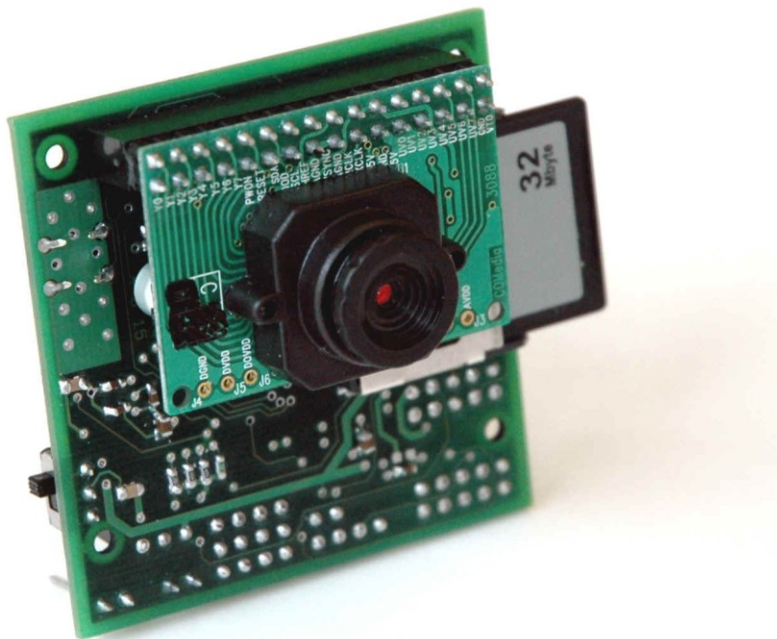

Figure 1.1: CMUcam

A **CMUcam** is a low cost computer vision device intended for robotics research. CMUcams consist of a small video camera and a microcontroller with a serial interface. While other digital cameras typically use a much higher bandwidth connector, the CMUcam's lightweight interface allows it to be accessed by microcontrollers. More importantly, the on-board microprocessor supports simple image processing and color blob tracking, making rudimentary computer vision capable in systems that would previously have far too little power to do such a thing. It has been used in past years by the high-school FIRST Robotics Competition as a way of letting participants' robots track field elements and navigate autonomously. The CMUcam also has an extremely small form factor. For these reasons, it is relatively popular for making small, mobile robots. Unfortunately, we could not use this camera because the latest CMUcam named CMUcam 4, until recently marketed by SparkFun Electronics from August, 2012. As a result, we could not obtain this camera. However, for future work this camera is by far the best choice. It comes with Arduino Interface Library.

1.1.2 AVR CAM



Figure 1.2: AVRcam Front View

The AVRcam is a real-time image processing engine that utilizes an Omni vision OV6620 CMOS image sensor, mated with an Atmel AVR mega8 microcontroller to perform all of the image processing tasks. It can be thought of as a vision sub-system, with a well-defined interface that is accessible through a standard serial port. This interface provides high-level, post-processed image information to a primary system (PC, another embedded controller, BASIC Stamp, etc.) to utilize. This removes the burden of performing the image processing on the main system, and allows the developer to concentrate on how to use the high level image data to perform the task at hand.

The AVRcam provides an assortment of capabilities:

- Track up to 8 different colorful objects at 30 frames/second
- Configure the system to recognize up to 8 different user-defined colors
- Provide real-time tracked object statistics (number of objects, color of objects, bounding box) through a standard serial port
- Tracked image resolution of 88 x 144 pixels at 30 frames/second
- Perform full-resolution color image dumps
- Dumped image resolution of 176 x 144 pixels
- Low power consumption (the entire system only draws 57 mA)
- Small size (the entire system is 2.4" x 1.9")



Figure 1.3: AVRcam Rear View

In addition, a PC application called AVRcamVIEW was developed to support the AVRcam for purposes of evaluating and testing the system. The AVRcamVIEW provides the following capabilities:

- Take full-color snapshots (176 x 144 pixels) with the system and display the images (both raw Bayer data and interpolated color data)
- Easily create a Color Map of colors to track based on a snapshot (just click on the colors of interest and add them to the Color Map)
- Adjust the precision of each tracked color (i.e. provide a range of acceptable R-G-B values for each color), allowing the user to adjust the Color Map to the surrounding environment
- Display the real-time tracking results of each tracked object (with color and bounding box information)
- Record a tracking session for playback at a later time
- Test the system out in multiple OS platforms that are supported by Java 1.5 (both Windows and Linux are currently supported).

One of the most important benefits to the AVRcam is that it is completely open-source: hardware, software, design docs, everything. Unfortunately it is not available in the market these days.

1.1.3 IP CAMERA



Figure 1.4: IP Camera

The elaboration of IP camera is Internet Protocol Camera. It is a type of digital video camera which is used for surveillance, and which unlike analog closed circuit television (CCTV) cameras can send and receive data via a computer network and the Internet. There are two kinds of IP cameras:

- Centralized IP camera: This camera handles the recording, video and alarm management via a central Network Video Recorder.
- Decentralized IP camera: This camera does not require a central Network Video Recorder (NVR). The camera can record directly to digital storage media (flash drives, hard disk drives or network attached storage) via a built-in recording functionality.

Potential advantages:

- Visual communication is possible due to the two-way audio via a single network cable
- Higher image resolution: Resolution ranges from 640x480 to multi-megapixel resolution and HDTV image quality at 30 frames per second.
- Flexibility: IP cameras are mobile.
- Distributed intelligence: Scalability in analytics solutions is possible if video analytics are placed in the camera itself
- Transmission of commands for PTZ (pan, tilt, zoom) cameras via a single network cable.
- Encryption & authentication: Encryption and authentication methods (such as WEP, WPA, WPA2, TKIP, AES) in IP camera allows secure data transmission.
- Remote accessibility: Computers, mobile smart phones, located anywhere can be used to access videos from selected cameras.
- IP cameras are able to function on a wireless network. A router is used to do the initial configuration of the IP camera after which it can be used on a wireless network. Defense forces uses IP camera for navigation purposes.

- PoE - Power over ethernet. Additional power supply is not required to operate IP cameras. They draw power via an Ethernet cable using the PoE- protocol.

Potential disadvantages:

- Expensive and Bulky
- High network bandwidth requirements: 3 Mbit/s is required to operate a typical CCTV camera with resolution of 640x480 pixels and 10 frames per second (10 frame/s) in MJPEG mode.
- Technical barrier: Professional technician is required to install the system

The system is vulnerable and hence open to a wider audience of hackers and hoaxers if the video is transmitted over the public Internet rather than a private IP LAN. Criminals can hack into A CCTV system can easily be hacked into by criminals and hence security measures and personnel can be observed. Thus it facilitates criminal acts, rendering the surveillance counterproductive.

Our model required to be as light and as cheap as possible and since use of an IP Camera makes it both heavy and expensive it was deemed unfeasible.

1.1.4 SERIAL CAMERA

For embedded applications, recently there is a trend of using serial camera that can be interfaced directly to the microcontroller or microprocessor using RS232 or UART interface. Some of the serial camera devices available in the market are discussed below.

1.1.4.1 SEEED SERIAL CAMERA



Figure 1.5: Grove Serial Camera

Serial CMOS Camera brick is compact CMOS camera module easy for MCU use. It has integrated image processing DSP to generate 320*240 or 640*480 JPEG image, captured picture will be stored in internal buffer and transferred via UART port.

Features:

- Electronic Brick Interface
- JPEG compressed image
- 640x480/320x240 resolution
- Small and compact
- Protocol control

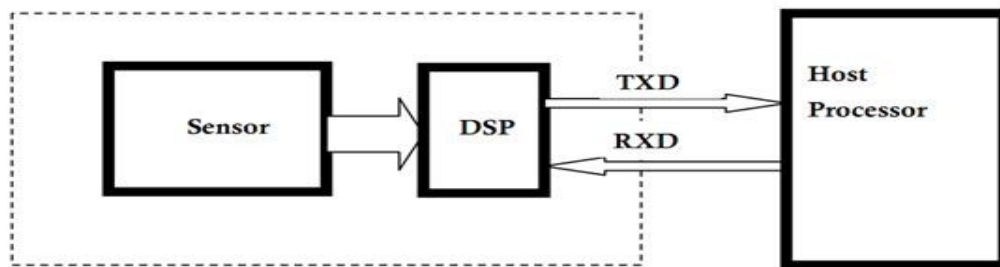

Figure 1.6: Block Diagram for Camera

Command Name	Command Content	Sensor ACK	Description
Capture frame VGA	0x55,0x41,0x52,0x54,0xCA,0x00,0x00,0x00,0x00,0x00,0x00	HH,HL,LL	Get frame and get frame size, Frame size =HH*65536+HL*256+LL
Capture frame QVGA	0x55,0x41,0x52,0x54,0xCA,0x00,0x00,0x00,0xFF,0x00,0x00		
Get Frame Data	0x55,0x41,0x52,0x54,0xC7, Addr1,Addr2,Addr3, Len1,Len2, Len3	Data from Address assigned, and length assigned	Get frame data from the address assigned, Address=Addr1*65536+Addr2*256+Addr3 Datalength=Len1*65536+Len2*256+Lens3
UpData Code	TBA	TBA	TBA test mode

Table 1.1: Protocol Diagram

Resolution	640*480, 320*240
Lens Size	1/6"
IO level	-0.3V ~ 5.5V
Operation Current	<160mA
Chief Ray Angle	25°
Dimension	60mm*45mm*24mm
Interface	4 Pin Electronic Brick (UART)
Power supply	5Vdc
Operation temperature	-20°C~ 70 °C
Storage temperature	-40 °C ~ 125 °C

Table 1.2: Specifications

PinNo	Pin Name	Description
1 (black)	GND	Power supply cathode
2 (red)	VDD	Power supply positive 5V
3 (white)	TXD	UART TTL TXD
4 (yellow)	RXD	UART TTL RXD

Table 1.3: Pin Definition and Rating

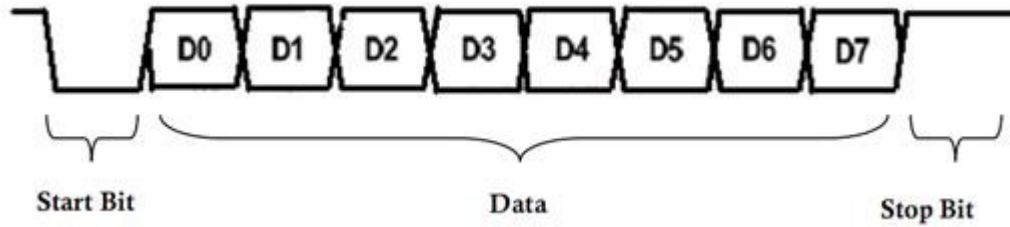

Figure 1.7: UART Timing Diagram

This camera is also very user friendly.

1.1.4.2 μ CAM



Figure 1.8: uCam

This is the camera we have used in our system. It comes in 2 models. We have used uCam-232. The uCAM (microCAM) is a highly integrated serial camera module which can be attached to any host system that requires a video camera or a JPEG compressed still camera for embedded imaging applications. The module uses an OmniVision CMOS VGA colour sensor along with a JPEG compression chip that provides a low cost and low powered camera system. The module has an on-board serial interface (TTL or RS232) that is suitable for a direct connection to any host micro-controller UART or a PC system COM port. User commands are sent using a simple serial protocol that can instruct the camera to send low resolution (160x120 or 80x60) single frame raw images for a quick viewing or high resolution (640x480 or 320x240) JPEG images for storage or viewing.

The uCAM comes in a compact form factor with a built in lens and a 4-wire connector that provides easy access to both power and serial data

Features:

- Small size, low cost and low powered camera module for embedded imaging applications.

uCAM-TTL: 3.3V DC Supply

uCAM-232: 5.0V DC Supply

- On-board EEPROM provides a command based interface to external host via TTL or RS-232 serial link .
- UART: up to 1.2Mbps for transferring JPEG still pictures or raw images.
- On board OmniVision OV7640/8 VGA colour sensor and JPEG CODEC for different resolutions.
- Built-in down sampling, clamping and windowing circuits for VGA, QVGA, 160x120 or 80x60 image resolutions.
- Built-in colour conversion circuits for 2-bit gray, 4-bit gray, 8-bit gray, 12-bit RGB, 16-bit RGB or standard JPEG preview images.
- No external DRAM required.

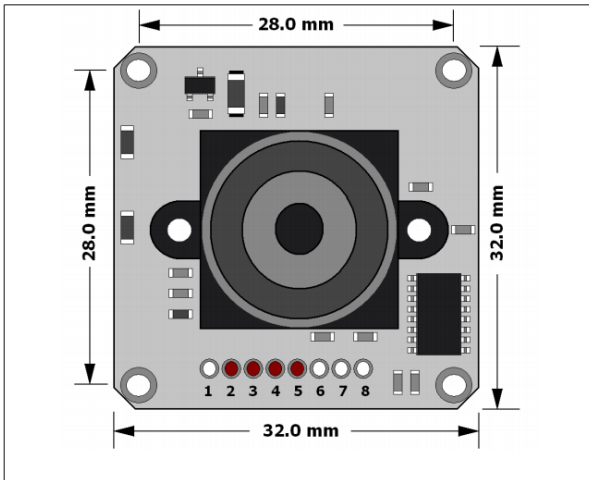

Figure 1.9: Pin Configuration

Pin	Symbol	I/O	Description
2	VCC	P	Main Voltage Supply +ve input pin. uCAM-TTL : 3.0V to 3.6V DC range nominal 3.3V. uCAM-232 : 4.5V to 5.5V DC range, nominal 5.0V.
3	GND	P	Supply Ground.
4	TX	O	Asynchronous Serial Transmit pin. Connect this pin to host controller Serial Receive (Rx) signal. The host receives data from uCAM via this pin.
5	RX	I	Asynchronous Serial Receive pin. Connect this pin to host controller Serial Transmit (Tx) signal. The host transmits commands to the uCAM via this pin.
1, 6, 7, 8	NC	--	No Connect.

Figure 1.10: Pin Description

Pin Description:

- VCC pin 2 (uCAM Supply Voltage Input): Module supply voltage input pin. This pin must be connected to a regulated supply voltage.
 - uCAM-TTL : 3.0V to 3.6V DC range, nominal 3.3V.
 - uCAM-232 : 4.5V to 5.5V DC range, nominal 5.0V.
- GND pin 3 (uCAM Ground): Module ground pin. This pin must be connected to ground.
- TX pin 4 (Serial Transmit): Asynchronous Serial port Transmit pin, TX. Connect this pin to host Serial Receive (Rx) signal. The host receives data from the uCAM module via this pin.

- RX pin 5 (Serial Receive): Asynchronous Serial port Receive pin, RX. Connect this pin to host Serial Transmit (Tx) signal. The host transmits data to the uCAM via this pin.

Serial Interface – UART:

The uCAM has a dedicated hardware UART that can communicate with a host via this serial port. This is the main interface used by the host to communicate with the module to send commands and receive back data. The primary features are:

- Full-Duplex 8 bit data transmission and reception through the TX and RX pins.
- Data format: 8 bits, No Parity, 1 Stop bit.
- Auto detect Baud rates from 14400 baud upto 115200 baud.
- Selectable Baud rates up to 1228800 bps.

The uCAM is available in 2 models that offer different versions of its serial interface. The uCAM-TTL has low voltage serial TTL levels which can be directly interfaced to a micro-controller and the uCAM-232 has a RS-232 voltage transceiver that can be interfaced to any host system COM port such as a PC.

Single Byte Timing:

A single byte serial transmission consists of the start bit, 8-bits of data followed by the stop bit. The start bit is always 0, while a stop bit is always 1. The LSB (Least Significant Bit, Bit 0) is sent out first following the start bit. Figure below shows a single byte transmission timing diagram.

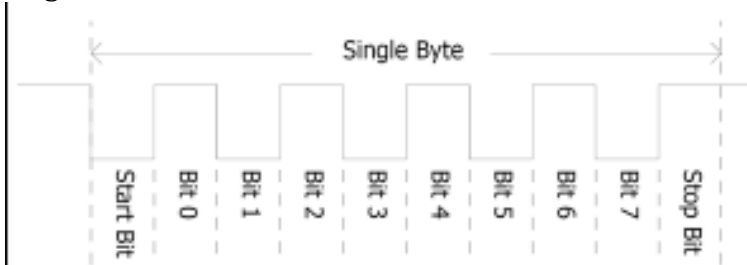

Figure 1.11: Single Byte Timing Diagram

Command Sequence Timing:

A single command consists of 6 continuous single byte serial transmissions. The following figure shows an example of the SYNC (AA0D0000000h) command.

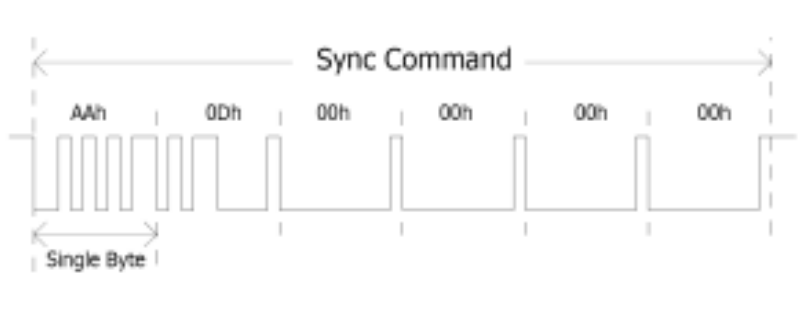

Figure 1.12: Command Sequence Timing Diagram

Auto-Baud Detect:

The module can auto-detect the baud rate of the incoming command. The host should make connection with one of the following baud rates:

- 14400 bps
- 56000 bps
- 57600 bps
- 115200 bps

The module will keep using the last baud rate until the next power cycle.

Setting the Baud Rates:

Baud rates can be set using the Set Baud command.

Baud rate = $14.7456\text{MHz} / 2 \times (2^{\text{nd}} \text{ Divider} + 1) / 2 \times (1^{\text{st}} \text{ Divider} + 1)$

The maximum Baud rate we can get is 1228800, which is achieved by following two combinations,

1st Divider = 0

2nd Divider = 2

Or

1st Divider = 2

2nd Divider = 0

Command Set:

The uCAM module supports a total of 10 commands:

Command	ID Number	Parameter1	Parameter2	Parameter3	Parameter4
INITIAL	AA01h	00h	Colour Type	RAW Resolution (Still Image only)	JPEG Resolution
GET PICTURE	AA04h	Picture Type	00h	00h	00h
SNAPSHOT	AA05h	Snapshot Type	Skip Frame (Low Byte)	Skip Frame (High Byte)	00h
SET PACKAGE SIZE	AA06h	08h	Package Size (Low Byte)	Package Size (High Byte)	00h
Set Baud Rate	AA07h	1 st Divider	2 nd Divider	00h	00h
RESET	AA08h	Reset Type	00h	00h	XXh*
DATA	AA0Ah	Data Type	Length Byte 0	Length Byte 1	Length Byte 2
SYNC	AA0Dh	00h	00h	00h	00h
ACK	AA0Eh	Command ID	ACK Counter	00h / Package ID Byte 0	00h / Package ID Byte 1
NAK	AA0Fh	00h	NAK Counter	Error Number	00h
LIGHT	AA13h	Frequency Type	00h	00h	00h

Figure 1.13: Command Set

If the parameter is 0xFF, the command is a special Reset command and the module responds to it immediately.

INITIAL (AA01h): The host issues this command to configure the preview image size and color type. After receiving this command, the module will send out an ACK command to the host if the configuration was successful. Otherwise, a NAK command will be sent out.

Color Type:

The uCAM can support 7 different color types as follow:

2-bit Gray Scale (RAW, 2-bit for Y only): 01h

4-bit Gray Scale (RAW, 4-bit for Y only):	02h
8-bit Gray Scale (RAW, 8-bit for Y only):	03h
8-bit Color (RAW, 332(RGB)):	04h
12-bit Color (RAW, 444(RGB)):	05h
16-bit Color (RAW, 565(RGB)):	06h
JPEG:	07h

RAW Resolution:

80 x 60:	01h
160 x 120:	03h
320 x 240:	05h
640 x 480:	07h
128 x 128:	09h
128 x 96:	0Bh

JPEG Resolution:

The uCAM embedded JPEG Code can support only multiples of 16 pixels, therefore the JPEG preview mode can only support following image sizes. It is different from the RAW preview mode.

80 x 64:	01h
160 x 128:	03h
320 x 240:	05h
640 x 480:	07h

GET PICTURE (AA04h):

The host issues this command to request a picture from the uCAM.

Picture Type:

Snapshot Picture:	01h
Preview (RAW) Picture:	02h
JPEG Picture:	05h

SNAPSHOT (AA05h):

The uCAM will hold a single frame of still picture data in its buffer after receiving this command.

Snapshot Type:

Compressed Picture (JPEG):	00h
Uncompressed Picture (RAW):	01h

Skip Frame Counter:

The number of dropped frames can be defined before capture occurs. "0" keeps the current frame, "1" captures the next frame, and so on.

SET PACKAGE SIZE (AA06h):

The host issues this command to change the size of the data package which is used to transmit the compressed JPEG image data from the uCAM to the host. This command should be issued before sending SNAPSHOT or GET PICTURE commands to the uCAM.

Package Size:

The default size is 64 bytes and the maximum size is 512 bytes.

- ID: Package ID, starts from zero for an image

- Data Size: Size of image data in the package
- Verify Code: Error detection code, equals to the lower byte of sum of the whole package data except the verify code field. The higher byte of this code is always zero.
i.e. verify code = lowbyte(sum(byte[0] to byte[N-2]))

RESET (AA08h):

The host can reset the uCAM by issuing this command.

Reset Type:

00h: Resets the whole system. The uCAM will reboot and reset all registers and state machines.

01h: Resets the state machines only.

DATA (AA0Ah):

The uCAM issues this command to inform the host the type and the size of the image data which is ready for transmitting to the host.

Data Type:

Snapshot Picture: 01h

Preview (RAW) Picture: 02h

JPEG Preview Picture: 05h

Length:

These three bytes represent the length of data of the Picture that is ready for transmission back to the host.

SYNC (AA0Dh):

Either the host or the uCAM module can issue this command to make a connection. The ACK command must be sent out after receiving this command. Refer to Section 5.2 for more details.

ACK (AA0Eh):

This command indicates the success of the last operation. After receiving any valid command, the ACK command must be sent out except when getting preview data. The host can issue this command to request image data package with the desired package ID after receiving the DATA command from the uCAM. The host should send this command with package ID F0F0h after receiving a package to end the package transfer.

Command ID:

The command with that ID is acknowledged by this command.

ACK Counter:

For debug only.

Package ID:

For acknowledging the DATA command, these two bytes represent the requested package ID. For acknowledging other commands, these two bytes are set to 00h.

NAK (AA0Fh):

This command indicates corrupted transmission or unsupported features.

NAK Counter:

For debug only.

Error Number:

Picture Type Error: 01h

Parameter Error: 0Bh

Picture Up Scale: 02h

Send Register Timeout: 0Ch

Picture Scale Error:	03h	Command ID Error:	0Dh
Unexpected Reply:	04h	Picture Not Ready:	0Fh
Send Picture Timeout:	05h	Transfer Package Number Error:	10h
Unexpected Command:	06h	Set Transfer Package Size Wrong:	11h
SRAM JPEG Type Error:	07h	Command Header Error:	F0h
SRAM JPEG Size Error:	08h	Command Length Error:	F1h
Picture Format Error:	09h	Send Picture Error:	F5h
Picture Size Error:	0Ah	Send Command Error:	FFh

LIGHT (AA13h):

The host issues this command to change the light frequency (hum) response of the uCAM.

Light Frequency Type:

50Hz: 00h

60Hz: 01h

Recommended Operating Conditions					
Parameter	Conditions	Min	Typ	Max	Units
uCAM-232					
Supply Voltage (VCC)		4.5	5.0	5.5	V
Input Voltage Range	RX pin	-25	--	25	V
uCAM-TTL					
Supply Voltage (VCC)		3.0	3.3	3.6	V
Input Voltage Range	RX pin	GND	--	VCC	V
uCAM-232, uCAM-TTL					
Operational Delay	After Synchronising	1000	2000	--	ms
Operating Ambient Temperature		-15		+70	°C
Storage Temperature	RH 95% max.	-40		+85	°C

Figure 1.14: Operating Conditions

Global Characteristics based on Operating Conditions					
Parameter	Conditions	Min	Typ	Max	Units
uCAM-232					
Supply Current (ICC)	VCC = 5.0V	60	64	80	mA
Output Voltage Range	TX pin	-5.0	--	5.0	V
uCAM-TTL					
Supply Current (ICC)	VCC = 3.3V	58	62	76	mA
Output Voltage Range	TX pin	GND	--	2.4	V

Figure 1.15: Ratings

Optical Characteristics	
Item	Parameter
Image Sensor	1/4" OmniVision CMOS, 300K pixels
Pixel Size	5.6um x 5.6um
SNR	45dB
Dynamic Range	60dB
White Balance	Automatic
Exposure	Automatic, self regulating, 1/50(1/60) – 1/100,000(sec)
Lens viewing angle(3 options)	60 degrees, 90 degrees, 120 degrees

Figure 1.16: Optical Characteristics

Since we have used this camera, detailed information has been provided.

1.2 COMMUNICATION SYSTEM

This chapter focuses on the different communication mechanism that can be implemented for a low cost – low power communication system. It is to be noted that, we have used a wifi router with Arduino Ethernet Shield for the wireless communication.

1.2.1 WIMAX

WiMAX otherwise known as Worldwide Interoperability for Microwave Access is a wireless communication system. It has a capacity of 30 to 40 Mbit per second. For fixed stations it can provide a data rate of 1 Gbit/s. Deployment of Wimax network is relatively cheap, which makes it economically suitable for providing last-mile broadband internet connections in secluded locations. It can also provide mobile internet access.

Devices that provide connectivity to a WiMAX network are known as the subscriber station (SS).

Portable units include handsets (similar to cellular smartphones); PC peripherals (PC Cards or USB dongles); and embedded devices in laptops, which are now available for Wi-Fi services.

Gateways:

Most manufacturers produce both indoor and outdoor versions of WiMAX gateway devices. Typically the Wimax gateway devices are stand-alone self-install indoor units, which get the best possible signal when placed near the customer's window with the best signal.

These gate way devices provide,

- An integrated Wi-Fi access point to provide the WiMAX Internet connectivity to multiple devices throughout the home or business.
- Ethernet ports to connect directly to a computer or DVR instead.
- One or two analog telephone jacks to connect a land-line phone and take advantage of VoIP.
- Indoor gateways are convenient, but radio losses mean that the subscriber may need to be significantly closer to the WiMAX base station than with professionally-installed external units.
- Outdoor units are bulky and their installation cost is expensive. They have greater range but are fixed at one location.
- External modems

- Connection to WiMAX can also be achieved via USB connected to a laptop or computer. They have omni-directional antennas with lower gain and hence need to be used in areas of good coverage.
- Mobile phones
- Recently mobile phones have been equipped with the technology to provide connectivity to a WiMax network.

Comparisons and confusion between WiMAX and Wi-Fi:

- WiMAX is a long range system, covering many kilometers that uses licensed or unlicensed spectrum to deliver connection to a network, in most cases the Internet whereas Wi-Fi uses unlicensed spectrum to provide access to a local network.
- Wi-Fi is more popular in end user devices.
- Wi-Fi runs on the Media Access Control's CSMA/CA protocol, which is connectionless and contention based, whereas WiMAX runs a connection-oriented MAC.
- WiMAX and Wi-Fi have quite different quality of service (QoS) mechanisms:
- WiMAX uses a QoS mechanism based on connections between the base station and the user device. Each connection is based on specific scheduling algorithms.
- Wi-Fi uses contention access - all subscriber stations that wish to pass data through a wireless access point (AP) are competing for the AP's attention on a random interrupt basis. This can cause subscriber stations distant from the AP to be repeatedly interrupted by closer stations, greatly reducing their throughput.

Due to the above mentioned advantages of WiMAX, we had planned to use a WiMAX transceiver chip for embedded application from Atmel, AT86RF535 and AT86RF525 are especially designed for WiMAX embedded application. Since, they were unavailable we opted for WIFI.

1.2.2 XBEE

XBee is the brand name for a family of form factor compatible radio modules.

To operate, the XBee radios require a minimum of four connections- VDD, GND, Data In and Data out. Other connections include reset and sleep lines. Most of the modules have built in flow control, A/D, I/O and indicator lines. XBees with onboard processor for containing the user code are called programmable XBee..

Most of the XBees come with several antenna options although not all variants have exactly the same connectors. The U.FL connector is common to all families, and all variants come with either a Chip antenna or an embedded PCB trace antenna. Other antennas include an integrated ¼ wave whip and an RP-SMA connector for bulkhead antennas.

There are two types of mode in which XBees can operate: a transparent data mode & a packet based application programming interface (API) mode. In the transparent mode data coming into the Data IN (DIN) pin gets directly transmitted to the intended receiving radios without any modification. Incoming packets can either be directly addressed to one target or broadcast to multiple targets. This mode is primarily used in instances where an existing protocol cannot tolerate changes to the data format. AT commands are used to control the radio's settings. In API mode the data is wrapped in a packet structure that allows for addressing, parameter setting and packet delivery feedback, including remote sensing and control of digital I/O and analog input pins.

The XBee Internet Gateway makes it easy to connect XBee radios to the Internet. The XIG runs on Windows, Macintosh and Linux computers as well as the Digi ConnectPort X series of gateways. It allows XBee radios to upload data, receive remote text and commands, access Internet resources such as web pages, databases, social networks, and use the iDigi device cloud.

SparkFun Electronics has an Arduino Xbee Shield for direct interfacing with Xbee. This method can be implemented for future work.

1.2.3 RF

The frequency in the range of 3 kHz to 300GHz which corresponds to that of radio waves is called radio frequency. Alternating currents carrying radio signals oscillate at radio frequency. They have spectral properties different from that of direct current or alternating current oscillating at lower frequencies. The energy in an RF current can radiate off a conductor into space as electromagnetic waves (radio waves); this is the basis of radio technology. Instead of flowing through the conductor, RF current tends to flow along their surfaces, a phenomenon known as the skin effect. The current at radio frequency oscillates very quickly and therefore cannot create depolarization of the nerve membranes. Hence when applied to the body they cannot create the sensation of electric shock. RF current is used in electric arc welding as they can ionize air, thereby creating a conducting path. They can travel through insulating materials, like the dielectric insulator of a capacitor. RF current can be reflected by discontinuities or irregularities in its path and travel back down the cable towards its source, causing a condition called standing wave. An antenna is used as a receiver for radio signals. It is equipped with a radio tuner to pick up a particular frequency. The tuner is basically a resonator circuit consisting of a capacitor & an inductor. The resonator amplifies oscillations within a particular frequency band while it reduces oscillations outside the band.

This is by far, most commonly used for Aerial Surveillance. Usually, a multi-channel RF transceiver is required. It is very difficult to ensure that the signals are being transmitted and received through a secure channel.

1.2.4 BLUETOOTH

Bluetooth is a proprietary open wireless technology standard that creates a personal area network between fixed or mobile devices (such as faxes, mobile phones, telephones, laptops, personal computers, printers, Global Positioning System (GPS) receivers, digital cameras, and video game consoles) with high level of security for exchanging data over short distances.

Bluetooth uses a radio technology called frequency-hopping spread spectrum, which chops up the data being sent and transmits chunks of it on up to 79 bands (1 MHz each; centered from 2402 to 2480 MHz) in the range 2,400–2,483.5 MHz (allowing for guard bands). This range is in the globally unlicensed Industrial, Scientific and Medical (ISM) 2.4 GHz short-range radio frequency band. It usually performs 800 hops per second, with AFH enabled.

Bluetooth is a packet-based protocol with a master-slave structure. One master may communicate with up to 7 slaves in a piconet; all devices share the master's clock. Packet exchange is based on the basic clock, defined by the master, which ticks at 312.5 μ s intervals. Two clock ticks make up a slot of 625 μ s; two slots make up a slot pair of 1250 μ s. In the simple case of single-slot packets the master transmits in even slots and receives in odd slots; the slave, conversely, receives in even slots and transmits in odd slots. Packets may be

1, 3 or 5 slots long but in all cases the master transmit will begin in even slots and the slave transmit in odd slots.

Bluetooth vs. Wi-Fi:

Bluetooth and Wi-Fi have some similar applications: setting up networks, printing, or transferring files. Wi-Fi is intended as a replacement for cabling for general local area network access in work areas. This category of applications is sometimes called wireless local area networks (WLAN). Bluetooth was intended for portable equipment and its applications. The category of applications is outlined as the wireless personal area network (WPAN). Bluetooth is a replacement for cabling in a variety of personally carried applications in any setting and also works for fixed location applications such as smart energy functionality in the home (thermostats, etc.). Wi-Fi is a wireless version of a common wired Ethernet network, and requires configuration to set up shared resources, transmit files, and to set up audio links (for example, headsets and hands-free devices). Wi-Fi uses the same radio frequencies as Bluetooth, but with higher power, resulting in higher bit rates and better range from the base station. Due to the above mentioned advantages of Wi-Fi over Bluetooth, we did not use Bluetooth.

1.2.5 WIFI

Wi-Fi is a popular technology that allows an electronic device to exchange data wirelessly using radio waves over a computer network, including high-speed Internet connections. Connection to a network resource such as the Internet via a wireless network access point is accessible by devices that use Wi-Fi. The range of such an access point (or hotspot) is about 20 meters (65 feet) indoors and much greater outdoors. Using multiple overlapping access points the hotspot coverage can be varied from a small room with walls that block radio waves to a large area (many square miles). A wireless network interface controller is needed for a computer to connect to a Wi-Fi LAN. The combination of computer and interface controller is called a *station*. All stations share a single radio frequency communication channel. Transmissions on this channel are received by all stations within range. The hardware does not signal the user that the transmission was delivered and is therefore called a best-effort delivery mechanism. A carrier wave is used to transmit the data in packets, referred to as "Ethernet frames". Each station is constantly tuned in on the radio frequency communication channel to pick up available transmissions.

Internet Access:

A Wi-Fi-enabled device can connect to the Internet when within range of a wireless network. The coverage of one or more (interconnected) access points— called hotspots — can extend from an area as small as a few rooms to as large as many square miles. Coverage in the larger area may require a group of access points with overlapping coverage. Routers that incorporate a digital subscriber line modem or a cable modem and a Wi-Fi access point, often set up in homes and other buildings, provide Internet access and internetworking to all devices connected to them, wirelessly or via cable.

Direct computer-to-computer communications:

Wi-Fi also allows communications directly from one computer to another without an access point intermediary. This transfer of files and sharing of media can be achieved using Wi-fi

Advantages:

Deployment of LANs becomes cheaper using Wi-Fi. It can access places where cables are restricted or cannot reach. It is an economical networking option as the price of Wi-Fi chipsets continues to fall. Different competitive brands of access points and client network-interfaces can inter-operate at a basic level of service. Products designated as "Wi-Fi Certified" by the Wi-Fi Alliance are backwards compatible. Unlike mobile phones, any standard Wi-Fi device will work anywhere in the world. It is a secure means of communication. It is suitable for latency sensitive applications as the new protocols for quality of service are implemented. Battery life is extended due to the power saving mechanism.

Limitations:

Spectrum assignments and operational limitations are not consistent worldwide: most of Europe allows for an additional two channels beyond those permitted in the US for the 2.4 GHz band (1–13 vs. 1–11), while Japan has one more on top of that (1–14). As of 2007, Europe is essentially homogeneous in this respect. A Wi-Fi signal occupies five channels in the 2.4 GHz band. Any two channels numbers that differ by five or more, such as 2 and 7, do not overlap. The oft-repeated adage that channels 1, 6, and 11 are the *only* non-overlapping channels is, therefore, not accurate. Channels 1, 6, and 11 are the only *group of three* non-overlapping channels in the U.S. In Europe and Japan using Channels 1, 5, 9, and 13 for 802.11g and n is recommended. Equivalent isotropically radiated power (EIRP) in the EU is limited to 20 dBm (100 mW). The current 'fastest' norm, 802.11n, uses double the radio spectrum/bandwidth (40 MHz) compared to 802.11a or 802.11g (20 MHz). This means there can be only one 802.11n network on the 2.4 GHz band at a given location, without interference to/from other WLAN traffic. 802.11n can also be set to use 20 MHz bandwidth only to prevent interference in dense community.

Range:

Wi-Fi networks have limited range. A typical wireless access point might have a range of 32 m (120 ft) indoors and 95 m (300 ft) outdoors. Range also varies with frequency band. Wi-Fi in the 2.4 GHz frequency block has slightly better range than Wi-Fi in the 5 GHz frequency block. On wireless routers with detachable antennas, it is possible to improve range by fitting upgraded antennas which have higher gain in particular directions. Outdoor ranges can be improved to many kilometers through the use of high gain directional antennas at the router and remote device(s). Due to reach requirements for wireless LAN applications, Wi-Fi has fairly high power consumption compared to some other standards. Technologies such as Bluetooth (designed to support wireless PAN applications) provide a much shorter propagation range of <10m and so in general have lower power consumption. Other low-power technologies such as ZigBee have fairly long range, but much lower data rate. The high power consumption of Wi-Fi makes battery life in mobile devices a concern. Due to the complex nature of radio propagation at typical Wi-Fi frequencies, particularly the effects of signal reflection off trees and buildings, algorithms can only approximately predict Wi-Fi signal strength for any given area in relation to a transmitter. This effect does not apply equally to long-range Wi-Fi, since longer links typically operate from towers that transmit above the surrounding foliage. The practical range of Wi-Fi essentially confines mobile use to such applications as inventory-taking machines in warehouses or in retail spaces, barcode-reading devices at check-out stands, or receiving/shipping stations. Mobile use of Wi-Fi over wider ranges is limited, for instance, to uses such as in an automobile

moving from one hotspot to another. Other wireless technologies are more suitable for communicating with moving vehicles.

Wireless routers integrate a Wireless Access Point, ethernet switch, and internal router firmware application that provides IP routing, NAT, and DNS forwarding through an integrated WAN-interface. A wireless router allows wired and wireless ethernet LAN devices to connect to a (usually) single WAN device such as a cable modem or a DSL modem. A wireless router allows all three devices, mainly the access point and router, to be configured through one central utility. This utility is usually an integrated web server that is accessible to wired and wireless LAN clients and often optionally to WAN clients. This utility may also be an application that is run on a desktop computer. Since, Wi-Fi is very flexible, we incorporated it in our system. The actual method of implementation is discussed later.

CHAPTER 2 – SYSTEM OVERVIEW

The Aerial Surveillance Unit is a tele-operated device. It consists of 3 subsystems along with its main control system. The subsystems include the locomotion system, surveillance system and the communication system. The complete block diagram of the system is shown below. The main control system consists of Arduino Mega 2560 as the main control unit. The Arduino Mega 2560 is based on Atmel's ATmega 2560 microcontroller. The other peripherals are connected to the Arduino board. The complete system was powered using Li-Poly Batteries of 4.5V with 3 of them connected in Series to make a total of 13.5V.

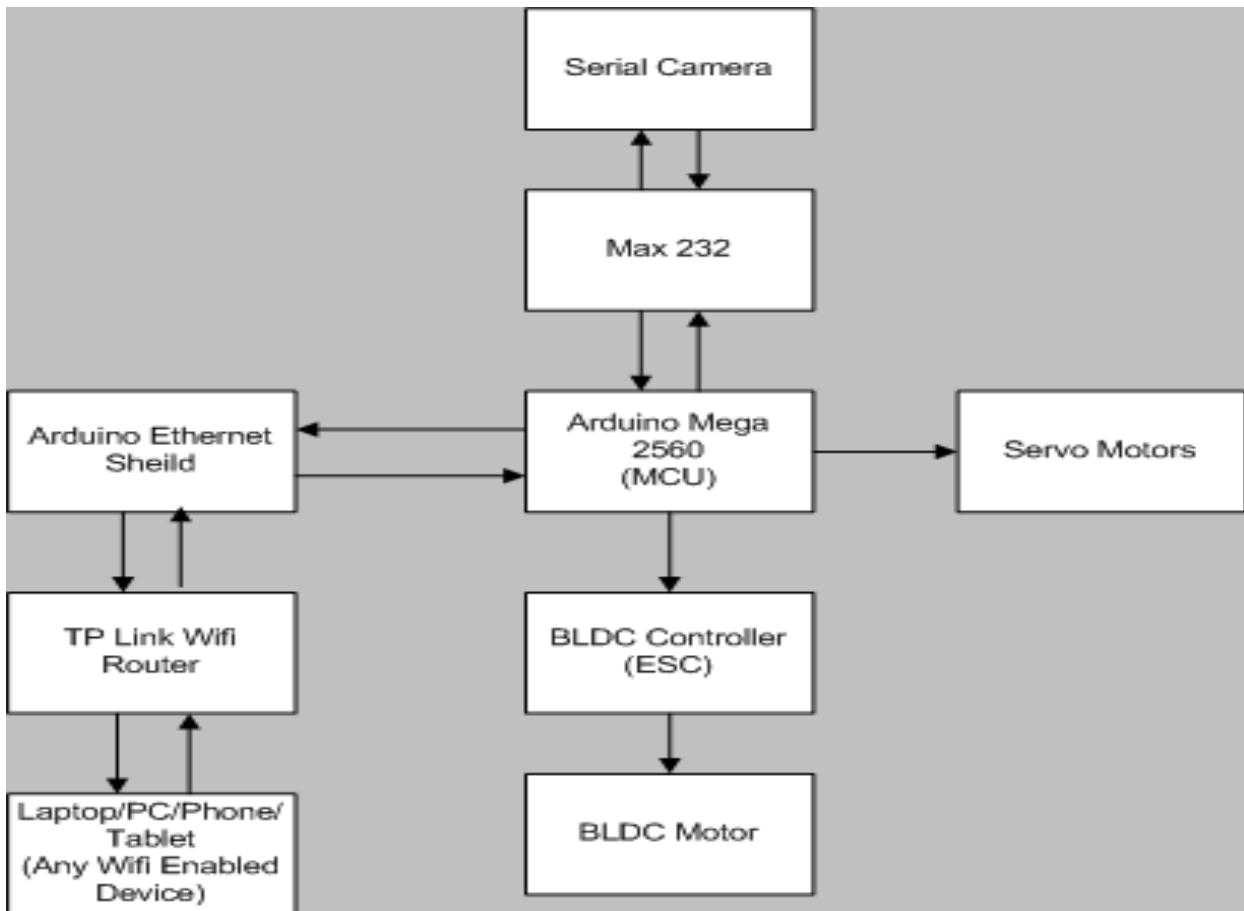

Figure 2.1: System Block Diagram

2.1 CAD DESIGN AND CONSTRUCTION

We made a preliminary design of our Aerial Surveillance Unit using the software named SolidWorks. The designs are shown below,

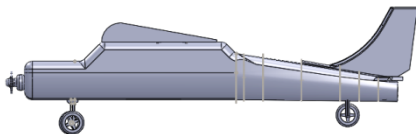

Figure 2.2: Side View

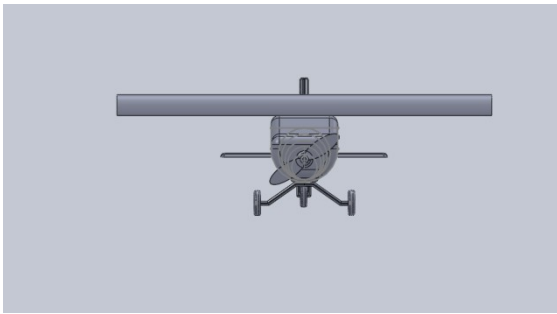

Figure 2.3: Front View

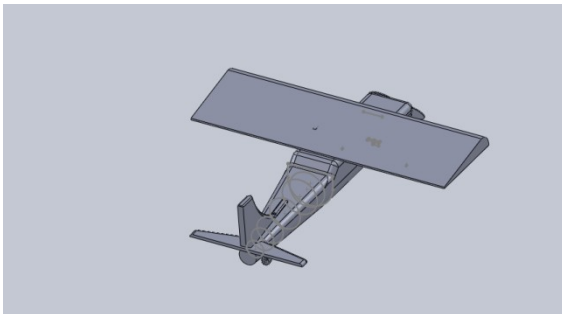

Figure 2.4: Top View

These were the initial designs. The motor and other circuit elements needed to operate the unit were supposed to be kept in an empty space right under the wing. But due to some complexities we decided to make slight modifications in the design during construction. The details of the construction are given below,

The materials used to construct the Aerial Surveillance Unit's Body are:

- Styrofoam
- Measuring Tape
- Anti cutter
- Glue
- Scales
- Tooth pick
- Sand paper

Reasons for using Styrofoam:

- It is light
- It is very dense

These are the two most important properties which materials of an airborne vehicle must have.

Modeling of the Aerial Unit:

From a single sheet of Styrofoam the appropriate design of the fuselage is cut out.

Using another sheet of Styrofoam appropriate shape of vertical stabilizers, rudder, horizontal stabilizers and the elevator are cut out. Two trapezoidal shape extensions are also cut which will act as support for the electrical equipments of the plane

The wing is made using a single sheet of Styrofoam. The wing is the main component that will provide the lift force and therefore need to be as thick as possible so that it can support the weight of the plane. This is done by cutting the Styrofoam in half and then gluing the two pieces together.

The pieces are cut very precisely and smoothly using a scale and an anti cutter. Any irregularities that remained are smoothed out using sand paper. The aerodynamic shape of the wings and the smoothness of the body are achieved by using sand paper. The pieces are then glued together in their appropriate places. The two extensions are glued on either side of the fuselage starting from the front edge of the wing to the tailing edge of the fuselage. In order to provide additional support to these connected components, tooth pick are used at the edges.

The dimensions of the aerial unit are given below:

- Fuselage length: 38 inches
- Wingspan: 38 inches in length & 10 inches in width

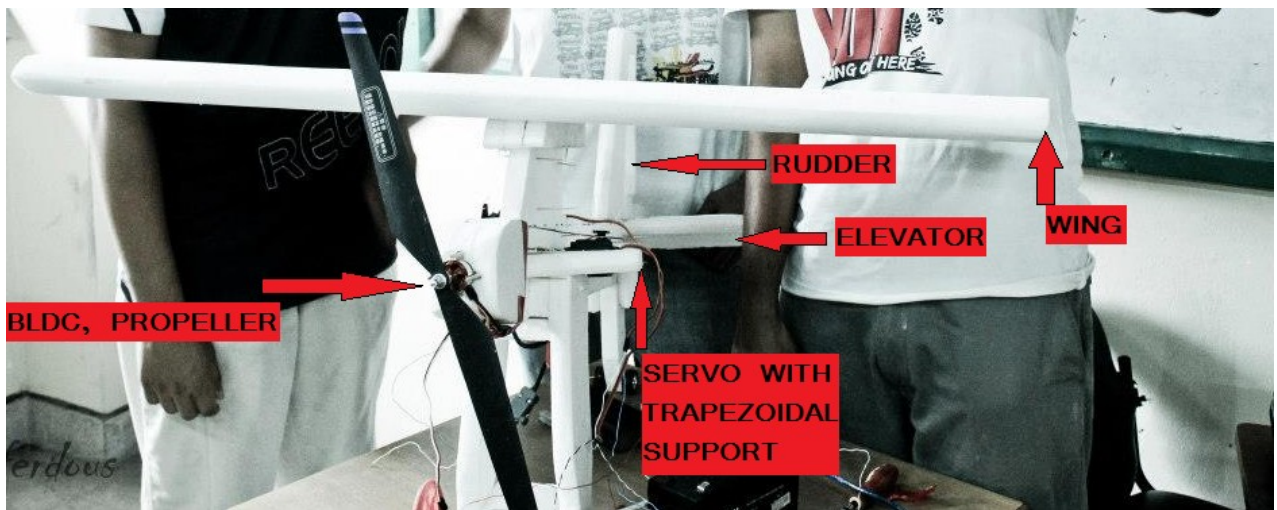

Figure 2.5: Aerial Surveillance Unit

After the construction of the Aerial Surveillance Unit has been completed, the electrical components are slowly added. The two actuators, which will control the motion of the rudder and the elevator, are placed on the two extensions. They are connected to the rudder and the elevator by means of a thin nylon thread. A shape similar to the dimensions of the actuator is cut out in each extension. This tightly holds the actuators in place. The BLDC motor, which is responsible for the forward motion is connected to the nose of the fuselage by means of tooth pick. To provide strength to the nose of the fuselage, two identical shapes are glued on either side of the nose. The camera is fixed below by means of tooth pick. The microcontroller and the router are placed on either side of the fuselage supported by tooth picks.

2.2 MAIN CONTROL SYSTEM

The main control system consists of an Arduino Mega 2560 board. The Arduino Mega 2560 is a microcontroller board based on the ATmega2560 (datasheet). It has 54 digital input/output pins (of which 14 can be used as PWM outputs), 16 analog inputs, 4 UARTs (hardware serial ports), a 16 MHz crystal oscillator, a USB connection, a power jack, an ICSP header, and a reset button. It contains everything needed to support the microcontroller; simply connect it to a computer with a USB cable or power it with a AC-to-DC adapter or battery to get started. The Mega is compatible with most shields designed for the Arduino Duemilanove or Diecimila. The Mega 2560 is an update to the Arduino Mega, which it replaces. The Mega2560 differs from all preceding boards in that it does not use the FTDI

USB-to-serial driver chip. Instead, it features the ATmega16U2 (ATmega8U2 in the revision 1 and revision 2 boards) programmed as a USB-to-serial converter. Revision 2 of the Mega2560 board has a resistor pulling the 8U2 HWB line to ground, making it easier to put into DFU mode. Revision 3 of the board has the following new features:

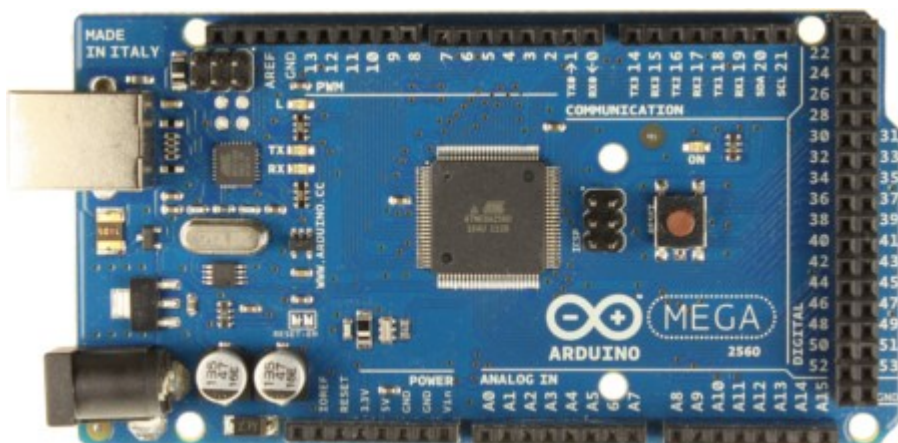

Figure 2.6: Arduino Mega 2560 Front View

- pinout: added SDA and SCL pins that are near to the AREF pin and two other new pins placed near to the RESET pin, the IOREF that allow the shields to adapt to the voltage provided from the board. In future, shields will be compatible both with the board that uses the AVR, which operate with 5V and with the Arduino Due that operate with 3.3V. The second one is a not connected pin that is reserved for future purposes.
- Stronger RESET circuit.
- Atmega 16U2 replace the 8U2.

Microcontroller	ATmega2560
Operating Voltage	5V
Input Voltage (recommended)	7-12V
Input Voltage (limits)	6-20V
Digital I/O Pins	54 (of which 15 provide PWM output)
Analog Input Pins	16
DC Current per I/O Pin	40 mA
DC Current for 3.3V Pin	50 mA
Flash Memory	256 KB of which 8 KB used by bootloader
SRAM	8 KB
EEPROM	4 KB
Clock Speed	16 MHz

Table 2.1: Summary of Specifications

Power:

The Arduino Mega can be powered via the USB connection or with an external power supply. The power source is selected automatically. External (non-USB) power can come either from an AC-to-DC adapter (wall-wart) or battery. The adapter can be connected by plugging a 2.1mm center-positive plug into the board's power jack. Leads from a battery can be inserted in the Gnd and Vin pin headers of the POWER connector. The board can operate on

an external supply of 6 to 20 volts. If supplied with less than 7V, however, the 5V pin may supply less than five volts and the board may be unstable. If using more than 12V, the voltage regulator may overheat and damage the board. The recommended range is 7 to 12 volts. The power pins are as follows:

- VIN. The input voltage to the Arduino board when it's using an external power source (as opposed to 5 volts from the USB connection or other regulated power source). One can supply voltage through this pin, or, if supplying voltage via the power jack, access it through this pin.
- 5V. this pin outputs a regulated 5V from the regulator on the board. The board can be supplied with power either from the DC power jack (7 - 12V), the USB connector (5V), or the VIN pin of the board (7-12V). Supplying voltage via the 5V or 3.3V pins bypasses the regulator, and can damage the board. We don't advise it.
- 3V3. A 3.3 volt supply generated by the on-board regulator. Maximum current draw is 50 mA.
- GND. Ground pins.

Memory:

The ATmega2560 has 256 KB of flash memory for storing code (of which 8 KB is used for the bootloader), 8 KB of SRAM and 4 KB of EEPROM (which can be read and written with the EEPROM library).

Input and Output:

Each of the 54 digital pins on the Mega can be used as an input or output, using `pinMode()`, `digitalWrite()`, and `digitalRead()` functions. They operate at 5 volts. Each pin can provide or receive a maximum of 40 mA and has an internal pull-up resistor (disconnected by default) of 20-50 kOhms. In addition, some pins have specialized functions:

- Serial: 0 (RX) and 1 (TX); Serial 1: 19 (RX) and 18 (TX); Serial 2: 17 (RX) and 16 (TX); Serial 3: 15 (RX) and 14 (TX). Used to receive (RX) and transmit (TX) TTL serial data. Pins 0 and 1 are also connected to the corresponding pins of the ATmega16U2 USB-to-TTL Serial chip.
- External Interrupts: 2 (interrupt 0), 3 (interrupt 1), 18 (interrupt 5), 19 (interrupt 4), 20 (interrupt 3), and 21 (interrupt 2). These pins can be configured to trigger an interrupt on a low value, a rising or falling edge, or a change in value. See the `attachInterrupt()` function for details.
- PWM: 2 to 13 and 44 to 46. Provide 8-bit PWM output with the `analogWrite()` function.
- SPI: 50 (MISO), 51 (MOSI), 52 (SCK), 53 (SS). These pins support SPI communication using the SPI library. The SPI pins are also broken out on the ICSP header, which is physically compatible with the Uno, Duemilanove and Diecimila.
- LED: 13. There is a built-in LED connected to digital pin 13. When the pin is HIGH value, the LED is on, when the pin is LOW, it's off.
- TWI: 20 (SDA) and 21 (SCL). Support TWI communication using the Wire library. Note that these pins are not in the same location as the TWI pins on the Duemilanove or Diecimila.

The Mega2560 has 16 analog inputs, each of which provide 10 bits of resolution (i.e. 1024 different values). By default they measure from ground to 5 volts, though it is possible to change the upper end of their range using the AREF pin and `analogReference()` function.

There are a couple of other pins on the board:

- AREF. Reference voltage for the analog inputs. Used with `analogReference()`.
- Reset. Bring this line LOW to reset the microcontroller. Typically used to add a reset button to shields which block the one on the board.

Communication:

The Arduino Mega2560 has a number of facilities for communicating with a computer, another Arduino, or other microcontrollers. The ATmega2560 provides four hardware UARTs for TTL (5V) serial communication. An ATmega16U2 (ATmega 8U2 on the revision 1 and revision 2 boards) on the board channels one of these over USB and provides a virtual com port to software on the computer (Windows machines will need a .inf file, but OSX and Linux machines will recognize the board as a COM port automatically). The Arduino software includes a serial monitor which allows simple textual data to be sent to and from the board. The RX and TX LEDs on the board will flash when data is being transmitted via the ATmega8U2/ATmega16U2 chip and USB connection to the computer (but not for serial communication on pins 0 and 1). A SoftwareSerial library allows for serial communication on any of the Mega2560's digital pins. The ATmega2560 also supports TWI and SPI communication. The Arduino software includes a Wire library to simplify use of the TWI bus; see the documentation for details. For SPI communication, use the SPI library.

Programming:

The Arduino Mega can be programmed with the Arduino software. The ATmega2560 on the Arduino Mega comes preburned with a bootloader that allows One to upload new code to it without the use of an external hardware programmer. It communicates using the original STK500 protocol. One can also bypass the bootloader and program the microcontroller through the ICSP (In-Circuit Serial Programming) header.

Physical Characteristics and Shield Compatibility:

The maximum length and width of the Mega2560 PCB are 4 and 2.1 inches respectively, with the USB connector and power jack extending beyond the former dimension. Three screw holes allow the board to be attached to a surface or case. Note that the distance between digital pins 7 and 8 is 160 mil (0.16"), not an even multiple of the 100 mil spacing of the other pins. The Mega2560 is designed to be compatible with most shields designed for the Uno, Diecimila or Duemilanove. Digital pins 0 to 13 (and the adjacent AREF and GND pins), analog inputs 0 to 5, the power header, and ICSP header are all in equivalent locations. Further the main UART (serial port) is located on the same pins (0 and 1), as are external interrupts 0 and 1 (pins 2 and 3 respectively). SPI is available through the ICSP header on both the Mega2560 and Duemilanove / Diecimila. Note that I²C is not located on the same pins on the Mega (20 and 21) as the Duemilanove / Diecimila (analog inputs 4 and 5). The pin mapping of Arduino Mega 2560 has been provided in Appendix A.

2.3 POWER SUPPLY



Figure 2.7: Li-Poly Battery

We have used 3 Rechargeable Li-Poly batteries in series. Each of the battery is rated at 4.5V and 2200mAh.

The table below shows the amount of maximum current drawn by each circuit component:

Component	Maximum Current/ mA
BLDC Motor	12000
Servo	1000
uCam-232	80
TP Link Wi-Fi Router	500
Others	130

Table 2.2: Maximum Current Drawn By Each Component

$$\text{Max Current Draw} = 12000 + 2 \times 1000 + 80 + 500 + 130 = 14710\text{mA}$$

$$\text{Discharge time for Max Current} = \frac{2200}{14710} \times 60 = 8.97\text{mins} \approx 9\text{mins}$$

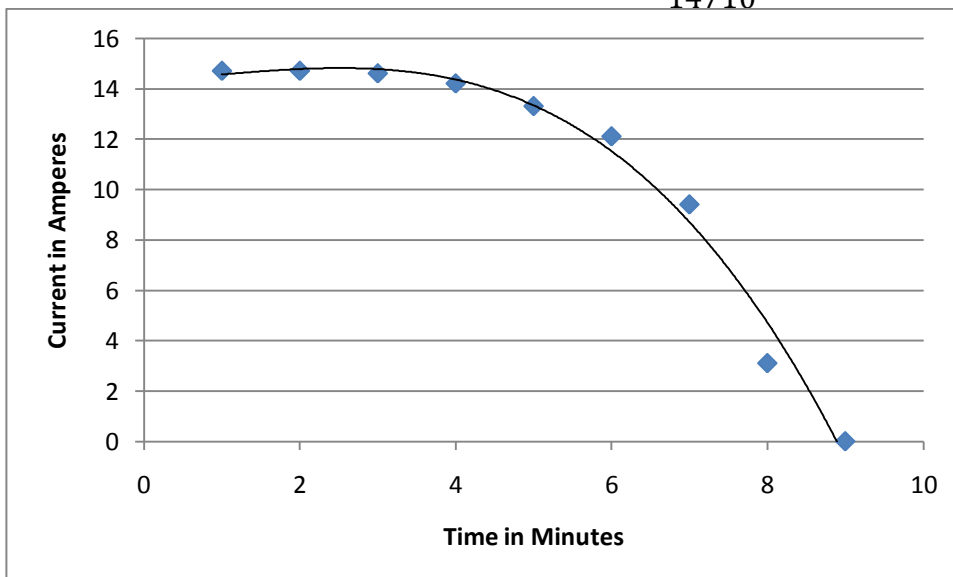

Figure 2.8: Current Supplied vs Time Graph

2.4 SURVEILLANCE SYSTEM

The surveillance system includes the uCam-232 JPEG Camera Module. It is a serial device. The details of the camera have been discussed in the previous chapter. The serial camera is given 5V power supply, via 7805 voltage regulator. The DB9 male port from the camera is connected to the DB9 female port on the PCB. The Tx-Rx pins of the camera are connected to the corresponding Tx-Rx of Max232. The TTL side Tx-Rx of Max232 is again connected to the MCU via J1 as shown in Appendix B. Pin1 of J1 goes to GND of MCU, Pin2 of J1 goes to Tx of MCU and Pin3 of J1 goes to Rx of MCU.

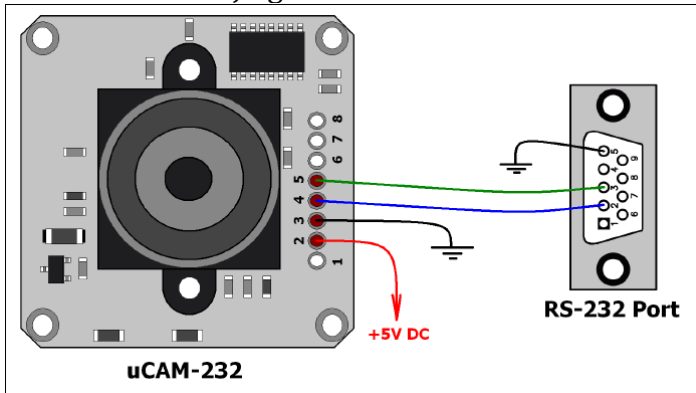

Figure 2.9: uCam-232 Connection Diagram

Figure 2.10 shows the 3D visualization of the PCB and Figure 2.11 shows the connection diagram for the uCam-232. The pin mapping of Max232 is shown in Figure 2.12. The Max232 IC is a dual transceiver that basically converts RS232 data to TTL/CMOS logic levels and vice versa.

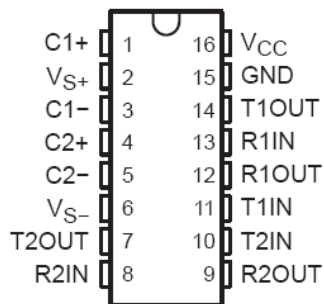

Figure 2.10: MAX232 IC

The uCam-232 needs to be synchronized for proper functioning. The SYNC command is send a maximum of 60 times till the camera returns ACK command. Usually after sending SYNC for 25 times, the ACK command is returned. Since, the camera has been synchronized. It is time to setup the camera for the desired mode. The process is outlined in Figure 2.11. The INITIAL command is used to setup the camera for JPEG or RAW, resolution, etc. Figure 2.12 shows the complete procedure. After the JPEG image is sent to the MCU. The MCU saves the file in a micro SD memory card present in the Memory Card Slot in the Arduino Ethernet Shield. Since, in the host end a web based interface is used. An IMG HTML tag is used to show the JPEG file saved in the memory card. This process is refreshed after a certain interval as soon as a new image arrives. Thus, continuous image data can be sent to the remote host. The process from image capturing to viewing at the remote host device takes about 2-3 seconds for 640 x 480 resolution image. At this rate the live video streaming is possible at 20 frames per minute, which is very slow. For lower resolution the performance is much better.

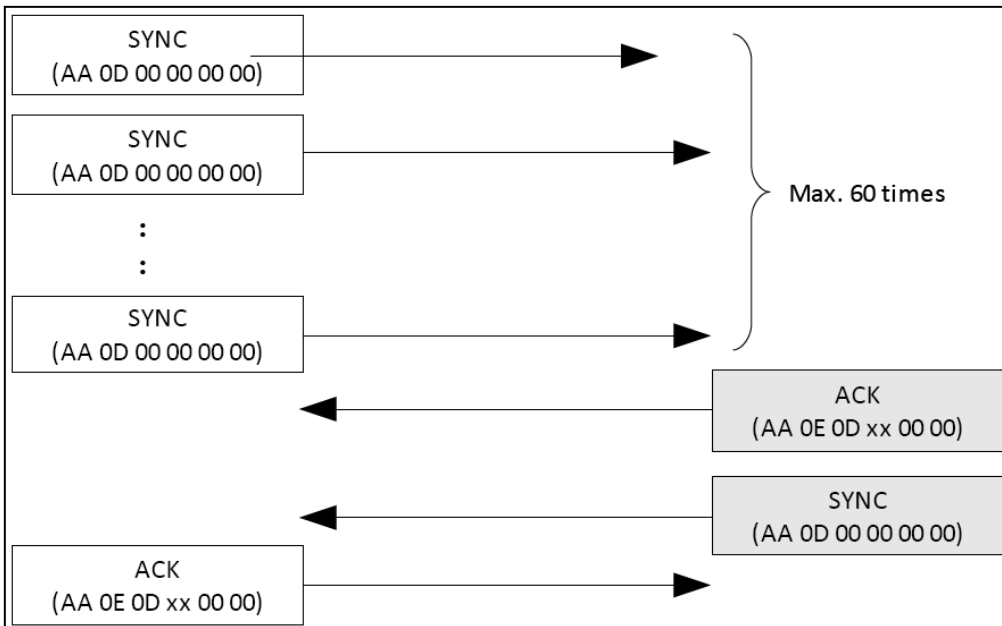

Figure 2.11: Synchronizing uCam

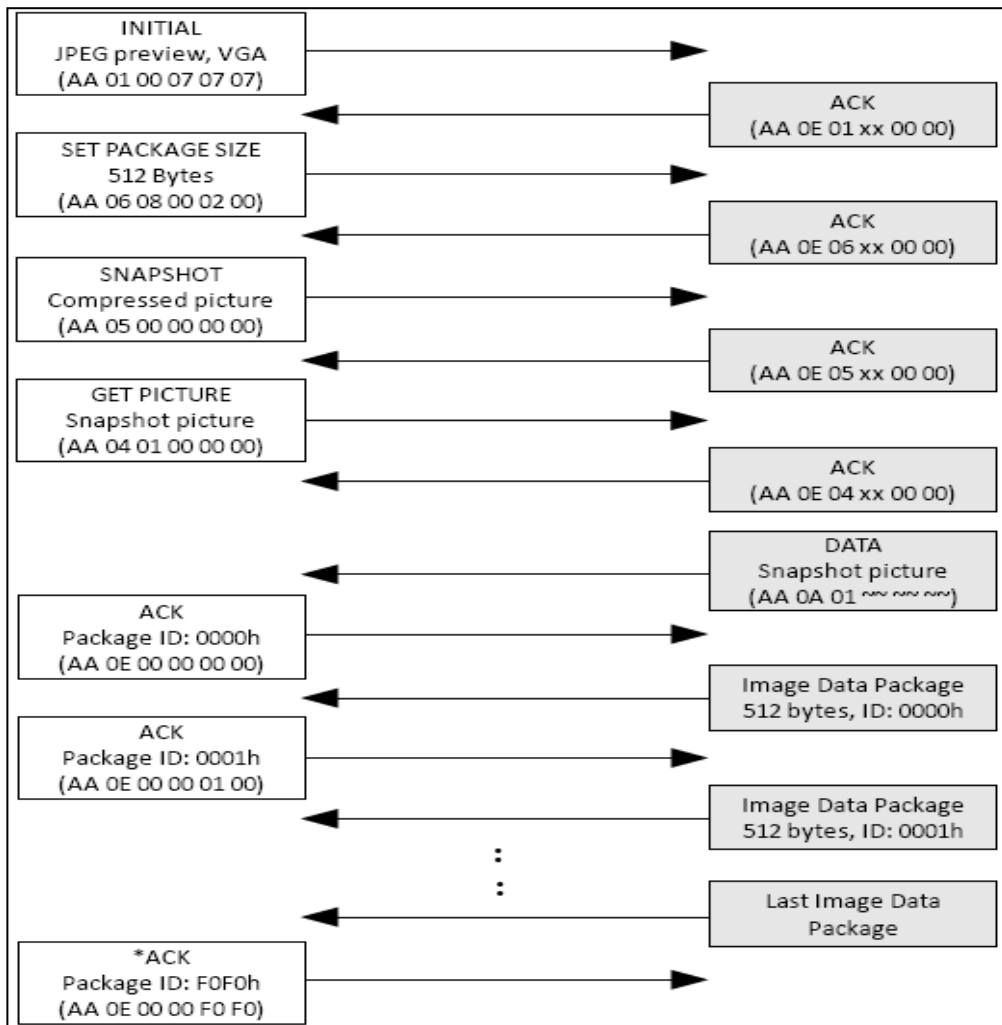

Figure 2.12: JPEG Image Capture

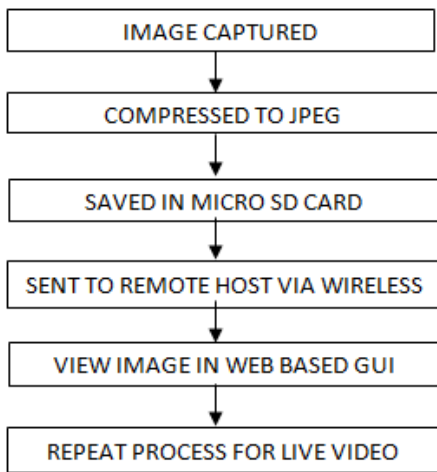

Figure 2.13: Process For Live Video

2.5 COMMUNICATION SYSTEM

The communication system consists of the Arduino Ethernet Shield, TP Link Router and the Remote Host (Laptop, PC, Phone, Tablet, Any Wifi Enabled Device with a Web Browser). The whole communication system is divided into two sections: The User Section & The Aerial Unit Section.

The User section consists of a remote host, that is WiFi enabled and has a web browser. The web browser works as the GUI for the User. The WiFi device acts as the transceiver. Control instructions from the user are given input using the web based GUI, which is then transmitted via wifi to the TP Link Router that is connected via Ethernet cable to the Arduino Ethernet Shield, which is connected to the Arduino Mega 2560 board with Aerial Surveillance Unit.

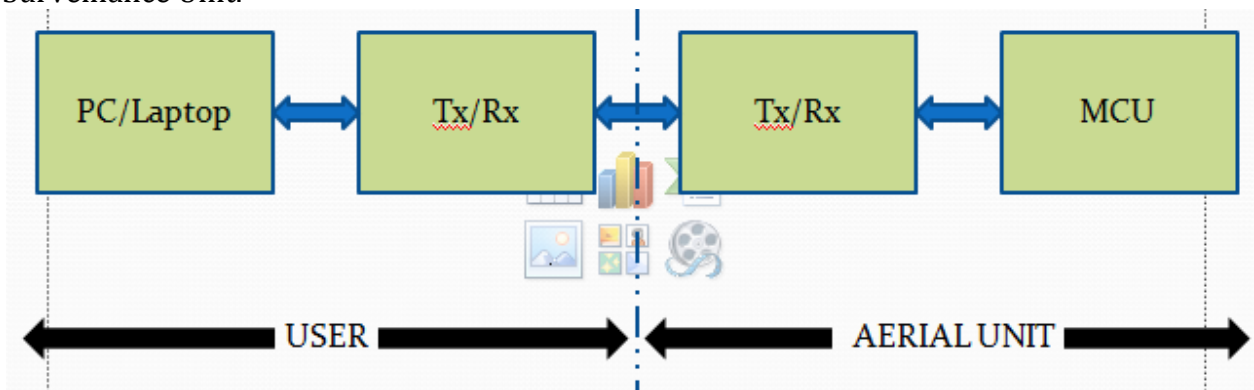

Figure 2.14: General Block Diagram for Communication Scheme

2.5.1 ARDUINO ETHERNET SHIELD



Figure 2.15: Arduino Ethernet Shield

The figure above shows the Arduino Ethernet Shield connected with an Arduino Board. The Ethernet cable is connected to the RJ-45 port and the Micro SD card inserted in the memory card slot.

Features for Arduino Ethernet Shield:

- Requires an Arduino board (not included)
- Operating voltage 5V (supplied from the Arduino Board)
- Ethernet Controller: W5100 with internal 16K buffer
- Connection speed: 10/100Mb
- Connection with Arduino on SPI port
- The reset button on the shield resets both the W5100 and the Arduino board.

The Arduino Ethernet Shield allows an Arduino board to connect to the internet. It is based on the Wiznet W5100 ethernet chip. The Wiznet W5100 provides a network (IP) stack capable of both TCP and UDP. It supports up to four simultaneous socket connections. The Ethernet library can be used to write sketches which connect to the internet using the shield. The ethernet shield connects to an Arduino board using long wire-wrap headers which extend through the shield. This keeps the pin layout intact and allows another shield to be stacked on top. The Ethernet Shield has a standard RJ-45 connection, with an integrated line transformer and Power over Ethernet enabled. There is an onboard micro-SD card slot, which can be used to store files for serving over the network. It is compatible with the Arduino Uno and Mega (using the Ethernet library). The onboard microSD card reader is accessible through the SD Library. When working with this library, SS is on Pin 4. The original revision of the shield contained a full-size SD card slot; this is not supported. The shield also includes a reset controller, to ensure that the W5100 Ethernet module is properly reset on power-up. Previous revisions of the shield were not compatible with the Mega and need to be manually reset after power-up.

The current shield has a Power over Ethernet (PoE) module designed to extract power from a conventional twisted pair Category 5 Ethernet cable:

- IEEE802.3af compliant
- Low output ripple and noise (100mVpp)
- Input voltage range 36V to 57V
- Overload and short-circuit protection
- 9V Output
- High efficiency DC/DC converter: typ 75% @ 50% load
- 1500V isolation (input to output)

The shield does not come with the PoE module built in; it is a separate component that must be added on. Arduino communicates with both the W5100 and SD card using the SPI bus (through the ICSP header). This is on digital pins 11, 12, and 13 on the Duemilanove and pins 50, 51, and 52 on the Mega. On both boards, pin 10 is used to select the W5100 and pin 4 for the SD card. These pins cannot be used for general I/O. On the Mega, the hardware SS pin, 53, is not used to select either the W5100 or the SD card, but it must be kept as an output or the SPI interface won't work. It is to be noted that because the W5100 and SD card share the SPI bus, only one can be active at a time. If we are using both peripherals in our program, this should be taken care of by the corresponding libraries. If we are not using one of the peripherals in our program, however, we will need to explicitly deselect it. To do this with the SD card, we have to set pin 4 as an output and write a high to it. For the W5100, we set digital pin 10 as a high output.

The shield contains a number of informational LEDs:

- PWR: indicates that the board and shield are powered
- LINK: indicates the presence of a network link and flashes when the shield transmits or receives data
- FULLD: indicates that the network connection is full duplex
- 100M: indicates the presence of a 100 Mb/s network connection (as opposed to 10 Mb/s)
- RX: flashes when the shield receives data
- TX: flashes when the shield sends data
- COLL: flashes when network collisions are detected

2.5.2 TP LINK ROUTER



Figure 2.16: TP Link Router, TL-WR340GD

Overview:

54Mbps Wireless Router TL-WR340GD integrates full-duplex 10/100Mbps switch, NAT-router and Wireless AP, which is dedicated to Small Office / Home Office (SOHO) allowing you to create a wired or wireless network, and let your computer to share a high-speed DSL network connection. Also, TL-WR340GD supports WDS wireless bridge offering seamless bridging to expand your network coverage, making it convenient for you to pick up the signal during different rooms or offices. When it comes to the installation, Easy Setup Assistant could lead you through the setup process step-by-step, and even helps with wireless network settings and security configurations, especially for novice users.

54Mbps Speed for Basic Internet Applications:

Wireless Router TL-WR340GD complies IEEE 802.11g standard with transmission rates up to 54Mbps, is designed to establish a better wireless connection than ever, sharing Internet Access, files-downloading and so on. Even among rooms with 1-2 walls, TL-WR340GD can also keep a useable signal and link rate after passing through the wall.

WDS Bridge - Expand Your Network:

During conventional wireless connection, you might found that signal degrades dramatically among rooms or offices at a long distance, which might not ensure your smooth downloading or uploading files. TL-WR340GD supports WDS bridging function, which can easily setup and expand the wireless network for wider coverage during long distance among obstacles.

WPA / WPA2 Encryptions - Advanced Security:

As for the security of WI-FI connection, WEP encryption has been no longer the strongest and safest guards for outside threats. TL-WR340GD provides WPA/WPA2 encryptions (Both Personal and Enterprises) that are created by the WI-FI Alliance industry group, preventing your network from outside intrusions efficiently.

Easy Setup:

Even novice users can easily setup their networking products. The device comes with a CD with an Easy Setup Assistant that leads you through the setup process step-by-step, and even helps with wireless network settings and security configurations.

Detachable Antenna:

TL-WR340GD offers 5dBi external antenna that can be rotated and adjusted in different directions to fit various operation environments, and can bring better performance than the internal antenna. For even more demanding applications, the detachable antenna can be replaced with diverse antennas to show even greater flexibility and wider wireless coverage.

Features:

- 54Mbps transmission rates, better for wireless network surfing or downloading
- WDS wireless bridge provides seamless bridging to expand your wireless network
- Support WEP / WPA / WPA2 encryption for advanced security
- Supports PPPOE, Dynamic IP, Static IP, L2TP, PPTP and BigPond Cable internet access
- Built-in firewall supporting IP/MAC address and domain filtering to control certain network access
- Easy Setup Assistant provides quick & hassle free installation
- Compatible with all the 802.11b/g products
- External detachable antennas allow for better alignment and stronger antenna upgrades

2.6 LOCOMOTION SYSTEM

2.6.1 SERVO MOTOR

Servos are DC motors with built in gearing and feedback control loop circuitry. No motor drivers required. Servos are extremely popular with robot, RC plane, and RC boat builders. Most servo motors can rotate about 90 to 180 degrees. Some rotate through a full 360 degrees or more. However, servos are unable to continually rotate, meaning they can't be used for driving wheels (unless modified), but their precision positioning makes them ideal for robot arms and legs, rack and pinion steering, and sensor scanners to name a few. Since servos are fully self contained, the velocity and angle control loops are very easy to implement, while prices remain very affordable. To use a servo, the following connection is required: the black wire to ground, the red to a 4.8-6V source, and the yellow/white wire to a signal generator (such as from microcontroller/555 timer). By varying the square wave pulse width from 1-2ms, the servo becomes position/velocity controlled. All servos have three wires:

- Black or Brown is for ground.
- Red is for power (~4.8-6V).
- Yellow, Orange, or White is the signal wire (3-5V).

Servos can operate under a range of voltages. Typical operation is from 4.8V to 6V. There are a few micro sized servos that can operate at less, and few servos operate at much more. The reason for this standard range is because most microcontrollers and RC receivers operate near this voltage. Unless we have a battery voltage/current/power limitation, we should operate at 6V. This is simply because DC motors have higher torque at higher voltages.

While the black and red wires provide power to the motor, the signal wire is what used to command the servo. The general concept is to simply send an ordinary logic square wave to the servo at a specific wave length, and the servo goes to a particular angle (or velocity if your servo is modified). The wavelength directly maps to servo angle. If the robot is remote controlled, the RC receiver will apply the proper square wave. If however the robot is running from a microcontroller it can be operated by bringing high a digital port wait between 1-2ms bring low the same digital port cycle a few dozen times per second.

If there are running multiple servos simultaneously, we can just put a few of these program blocks in sequential order. So we can run as many servos as we have digital ports. A simpler method will be to connect the servo signal pin with one of the PWM outputs. This will limit the number of servos used, since usually there is very limited number of PWM output pins. The standard time vs. angle is represented in this chart:

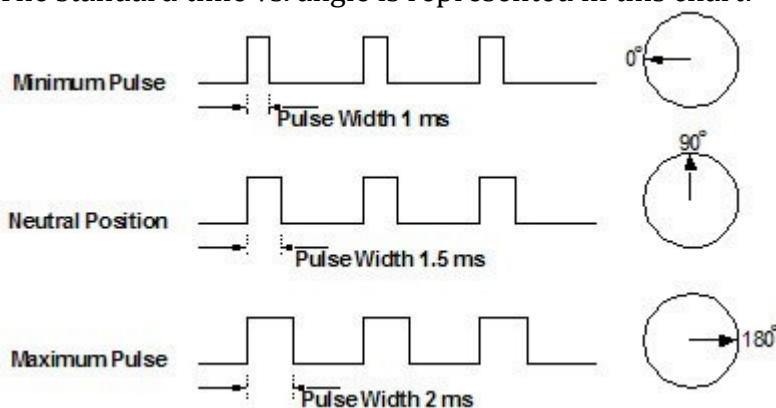

Figure 2.17: Pulse Width and Corresponding Angle

Servo Current:

Servo current operates the same as in a DC motor, except that we now have to predict feedback control system current. If the DC motor is not at the specified angle, it will suddenly draw huge amounts of current to reach that angle. But there are other peculiarities as well. If we run an experiment with a servo at a fixed angle and hang precision weights from the servo horn, the measured current will not be what we expect. One would think that the current would increase at some fixed rate as the weights increased linearly. Instead we will get unpredictable curves and multiple rates. In conclusion, servo current draw is very unpredictable.

Stall Torque, Stall Current, and Current Drain:

The stall characteristics are similar to that of the DC motor.



Figure 2.18: Servo Gears

Gear Types:

More expensive servos come with metal gears for higher torque and longer life, followed by karbonite and then nylon gears for the cheapest.

Nylon Gears - Nylon gears are most common in servos. They are extremely smooth with little or no wear factors. They are also very lightweight, but lack in durability and strength.

Karbonite Gears - Karbonite gears are relatively new to the market. They offer almost 5 times the strength of nylon gears and also better wear resistance. Cycle times of well over 300,000 have been observed with these gears with virtually no wear. Servos with these gears are more expensive but what we get in durability is more than equaled.

Metal Gears - Metal gears have been around for some time now. Although the heaviest and having the highest wear rate of all gear types, they offer unparalleled strength. With a metal output shaft, side-loads can be much greater. For some applications, metal gears are the best. Unfortunately, due to wear, metal gears will eventually develop slight play in the gear-train. Accuracy will slowly be lost.

Velocity:

The servo turn rate, or transit time, is used for determining servo rotational velocity. This is the amount of time it takes for the servo to move a set amount, usually 60 degrees. For example, suppose we have a servo with a transit time of 0.17sec/60 degrees at no load. This means it would take nearly half a second to rotate an entire 180 degrees. More if the servo were under a load. This information is very important if high servo response speed is a requirement of the robot application. It is also useful for determining the maximum forward velocity of your robot if the servo is modified for full rotation. The worst case turning time is when the servo is at the minimum rotation angle and is then commanded to go to maximum rotation angle, all while under load. This can take several seconds on a very high torque servo.

Efficiency and Noise:

Due to noise and control circuitry requirements, servos are less efficient than DC motors. To begin with, the control circuitry typically drains 5-8mA just on idle. Secondly, noise can more than triple current draw during a holding position (not moving), and almost double current during rotation. Noise is often a major source of servo inefficiency and therefore should be avoided. Sometimes the servo vibrates. This is because the servo is rapidly jumping between two different angles due to interference. This interference is caused since the signal wire is no different than a long antenna, capable of accepting unwanted foreign signals and sending them straight to the servo as a command. This problem can be solved by keeping the wires as short as possible.



Figure 2.19: Servo Control Circuitry

Digital Servos vs Analog Servos:

Digital servos, at the user end, are controlled no differently than analog servos. The difference is in how the servo motor is controlled via the circuit board (amplifier). The motor

of an analog servo receives a signal from the amplifier 30 times a second or at 30Hz. This signal allows the amplifier to update the motor position. Digital servos use a high frequency amplifier that updates the servo motor position 300 times a second or at 300Hz. By updating the motor position more often, the digital servo can deliver full torque from the beginning of movement and increases the holding power of the servo. With the exception of a higher cost, there are only advantages for digital servos over analog servos. The digital micro processor is 10 times faster than an analog servo. This results in a much quicker response from the beginning with the servo developing all the rated torque 1 degree off of the center point. This faster response also results in higher starting currents. Digital servos can be programmed for direction of rotation, center and end points, failsafe option, speed, and dead bandwidth adjustment.

The Aerial Surveillance Unit consists of 2 servo motors, each for the rudder and elevator. We have used the TowerPro MG995 analog servo motor.



Figure 2.20: TowerPro MG995

Modulation:	Analog
Torque:	4.8V: 138.9 oz-in (10.00 kg-cm)
Speed:	4.8V: 0.20 sec/60°
Weight:	1.94 oz (55.0 g)
Dimensions:	Length: 1.60 in (40.6 mm) Width: 0.78 in (19.8 mm) Height: 1.69 in (42.9 mm)
Motor Type:	Coreless
Gear Type:	Metal
Rotation/Support:	Dual Bearings

Table 2.3: Specificaitons For TowerPro MG995

2.6.2 BLDC MOTOR

Conventional dc motors are highly efficient and their characteristics make them suitable for use as servomotors. However, their only drawback is that they need a commutator and brushes which are subject to wear and require maintenance. When the functions of commutator and brushes were implemented by solid-state switches, maintenance-free motors were realised. These motors are now known as brushless dc motors. The construction of modern brushless motors is very similar to the ac motor, known as the permanent magnet synchronous motor. Figure 2.21 illustrates the structure of a typical three-phase brushless dc motor. The stator windings are similar to those in a polyphase ac motor, and the rotor is composed of one or more permanent magnets. Brushless dc motors are different from ac synchronous motors in that the former incorporates some means to detect the rotor position (or magnetic poles) to produce signals to control the electronic switches. The most common position/pole sensor is the Hall element, but some motors use optical sensors.

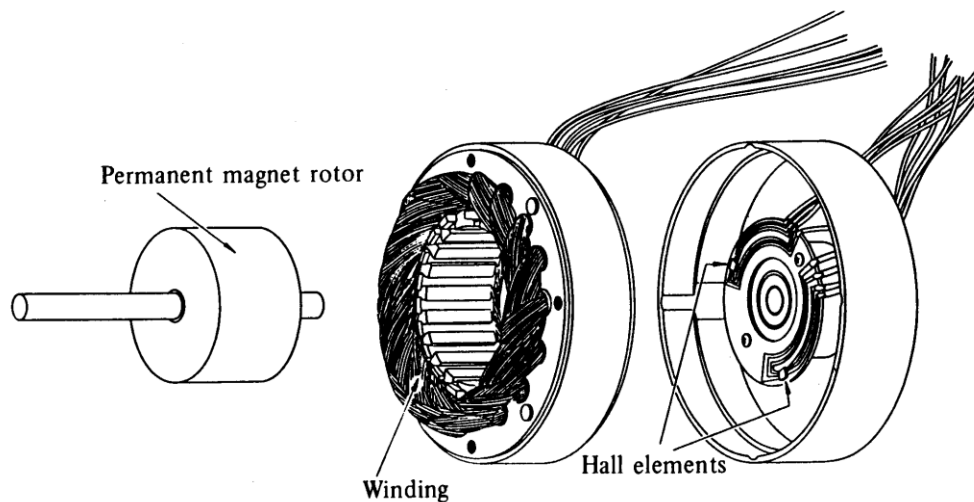

Figure 2.21: Brushless DC Motor Parts

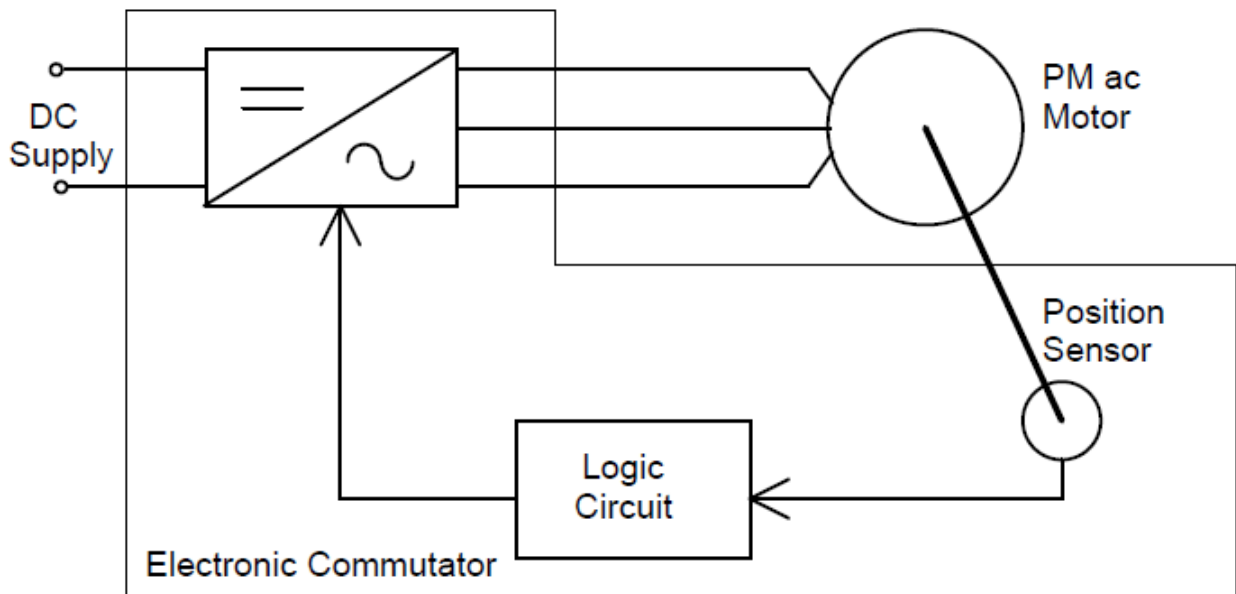

Figure 2.22: Block Diagram For BLDC Motor

Comparison of conventional and brushless dc motors:

Although it is said that brushless dc motors and conventional dc motors are similar in their static characteristics, they actually have remarkable differences in some aspects. When we compare both motors in terms of present-day technology, a discussion of their differences rather than their similarities can be more helpful in understanding their proper applications. Figure 2.23 compares the advantages and disadvantages of these two types of motors. When we discuss the functions of electrical motors, we should not forget the significance of windings and commutation. Commutation refers to the process which converts the input direct current to alternating current and properly distributes it to each winding in the armature. In a conventional dc motor, commutation is undertaken by brushes and commutator; in contrast, in a brushless dc motor it is done by using semiconductor devices such as transistors.

	Conventional motors	Brushless motors
Mechanical structure	Field magnets on the stator	Field magnets on the rotor Similar to AC synchronous motor
Distinctive features	Quick response and excellent controlability	Long-lasting Easy maintenance (usually no maintenance required)
Winding connections	Ring connection The simplest: Δ connection	The highest grade: Δ or Y-connected three-phase connection Normal: Y-connected three-phase winding with grounded neutral point, or four-phase connection The simplest: Two-phase connection
Commutation method	Mechanical contact between brushes and commutator	Electronic switching using transistors
Detecting method of rotor's position	Automatically detected by brushes	Hall element, optical encoder, etc.
Reversing method	By a reverse of terminal voltage	Rearranging logic sequencer

Figure 2.23: Comparison Between Conventional and Brushless Motors

Drive circuits:

Unipolar drive

Figure 2.24 illustrates a simple three-phase unipolar-operated motor that uses optical sensors (phototransistors) as position detectors. Three phototransistors PT1, PT2, and PT3 are placed on the end-plate at 120° intervals, and are exposed to light in sequence through a revolving shutter coupled to the motor shaft. The north pole of the rotor now faces the salient pole P2 of the stator, and the phototransistor PT1 detects the light and turns transistor Tr1 on. In this state, the South Pole which is created at the salient pole P1 by the electrical current flowing through the winding W1 is attracting the north pole of the rotor to move it in the direction of the arrow. When the North Pole comes to the position to face the salient pole P1, the shutter, which is coupled to the shaft, will shade PT1, and PT2 will be exposed to the light and a current will flow through the transistor Tr2. When a current flows

through the winding W_2 , and creates a south pole on salient pole P_2 , then the North Pole in the rotor will revolve in the direction of the arrow and face the salient pole P_2 . At this moment, the shutter shades PT_2 , and the phototransistor PT_3 is exposed to the light. These actions steer the current from the winding W_2 to W_3 . Thus salient pole P_2 is deenergized, while the salient pole P_3 is energized and creates the South Pole. Hence the North Pole on the rotor further travels from P_2 to P_3 without stopping. By repeating such a switching action in sequence given in Figure 2.25, the permanent magnet rotor revolves continuously.

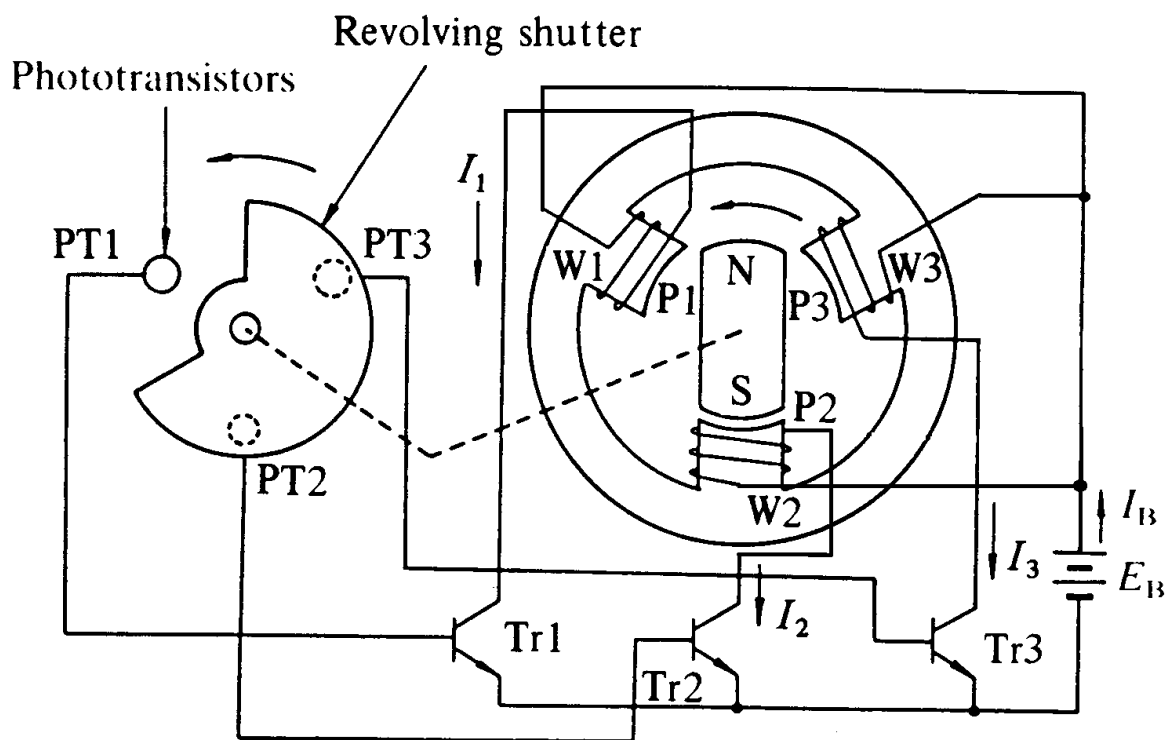
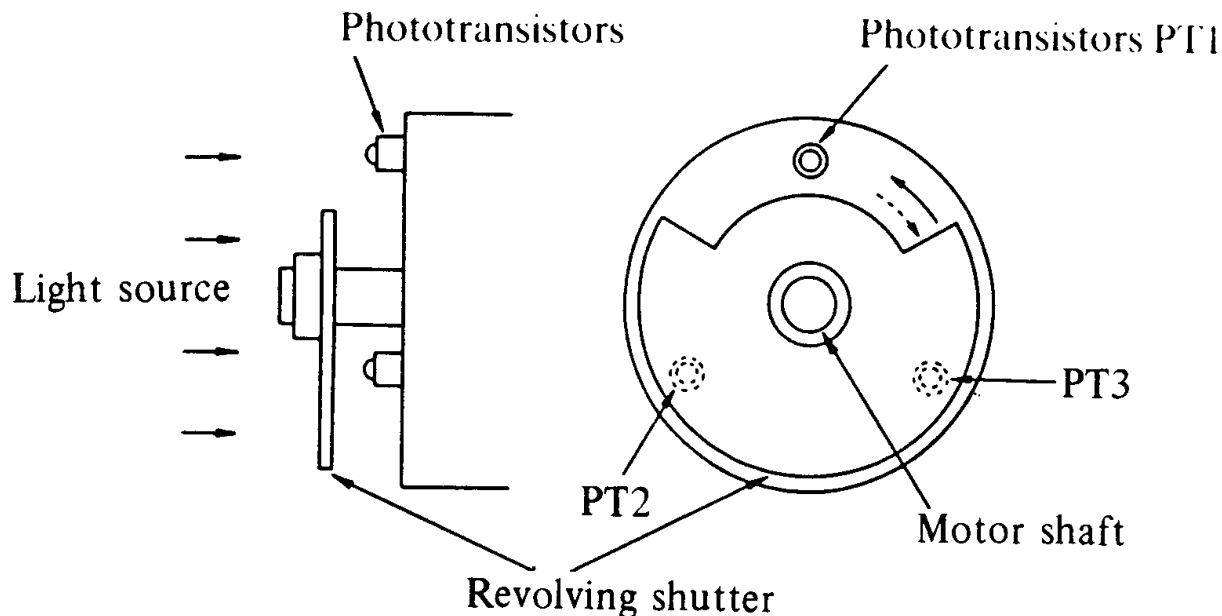

Figure 2.24: Three-Phase Unipolar Brushless DC Motor

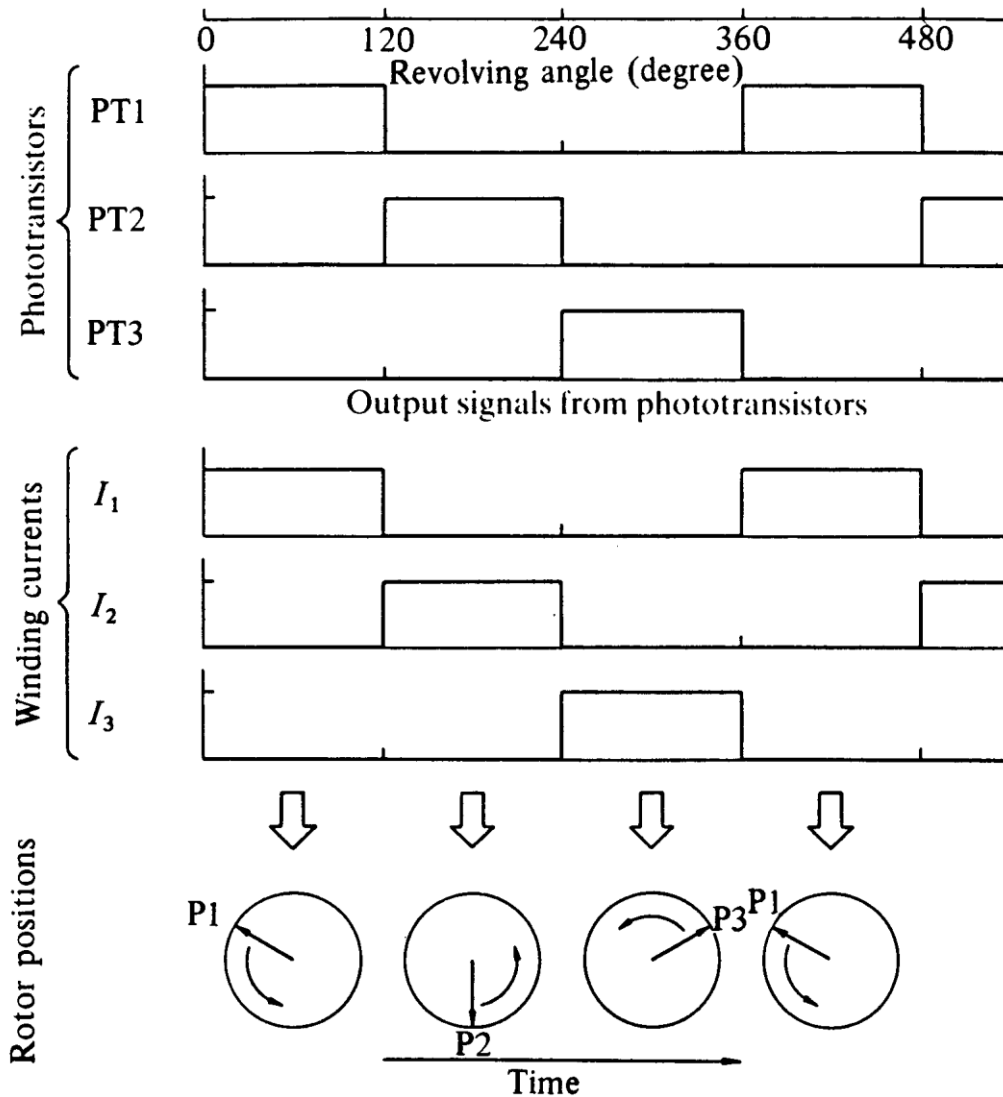

Figure 2.25: Switching Sequence and Rotation of Stator's Magnetic Field

Bipolar drive

When a three-phase (brushless) motor is driven by a three-phase bridge circuit, the efficiency, which is the ratio of the mechanical output power to the electrical input power, is the highest, since in this drive an alternating current flows through each winding as an ac motor. This drive is often referred to as 'bipolar drive'. Here, 'bipolar' means that a winding is alternatively energised in the south and north poles. We shall now survey the principle of the three-phase bridge circuit of Figure 2.26. Here too, we use the optical method for detecting the rotor position; six phototransistors are placed on the end-plate at equal intervals. Since a shutter is coupled to the shaft, these photo elements are exposed in sequence to the light emitted from a lamp placed in the left of the figure. Now the problem is the relation between the ON/OFF state of the transistors and the light detecting phototransistors. The simplest relation is set when the logic sequencer is arranged in such a way that when a phototransistor marked with a certain number is exposed to light, the transistor of the same number turns ON. Figure 2.26 shows that electrical currents flow through Tr1, Tr4, and Tr5, and terminals U and W have the battery voltage, while terminal V has zero potential. In this state, a current will flow from terminal U to V, and another current

from W to V as illustrated in Figure 2.27. We may assume that the solid arrows in this figure indicate the directions of the magnetic fields generated by the currents in each phase. The fat arrow in the centre is the resultant magnetic field in the stator.

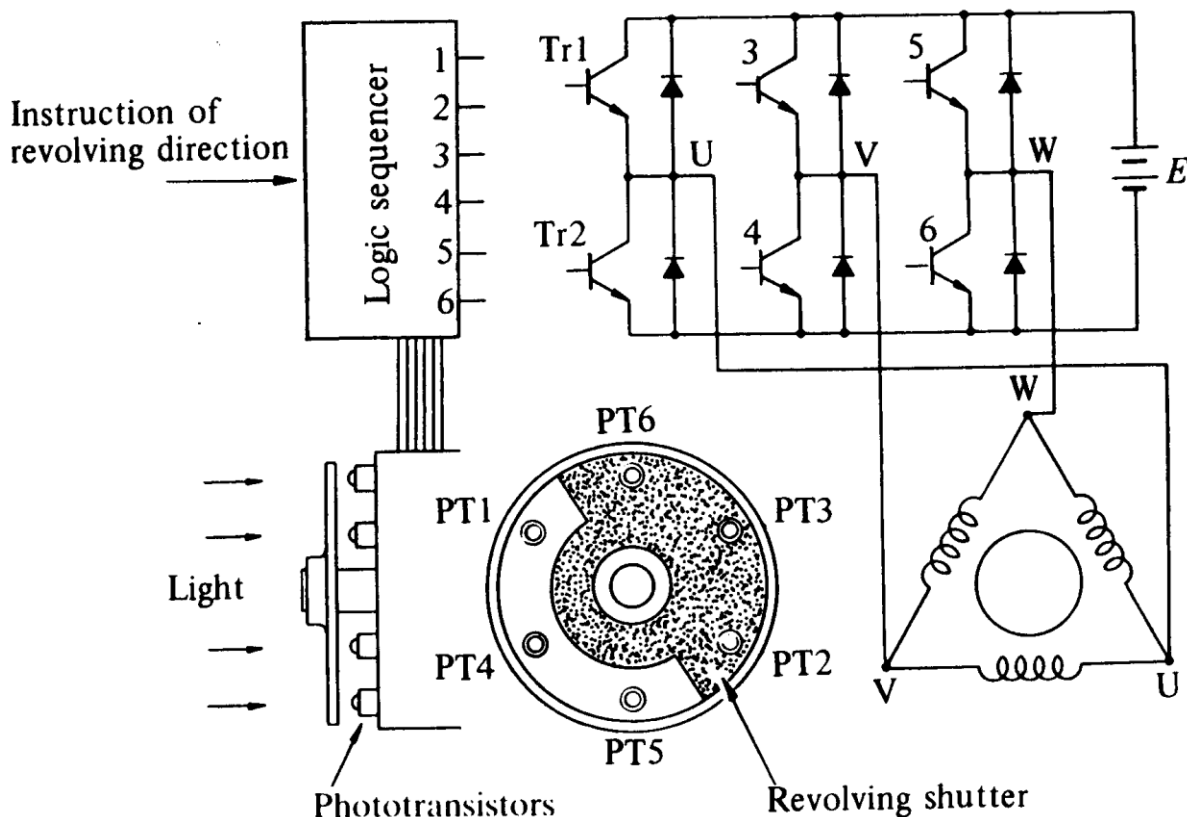

Figure 2.26: Three Phase Bipolar-Driven Brushless Motor

The rotor is placed in such a position that the field flux will have a 90° angle with respect to the stator's magnetic field as shown in Figure 2.27. In such a state a clockwise torque will be produced on the rotor. After it revolves through about 30° , PT5 is turned OFF and PT6 ON which makes the stator's magnetic pole revolves 60° clockwise. Thus when the rotor's south pole gets near, the stator's south pole goes away further to create a continuous clockwise rotation. The ON-OFF sequence and the rotation of the transistor are shown in Figure 2.28.

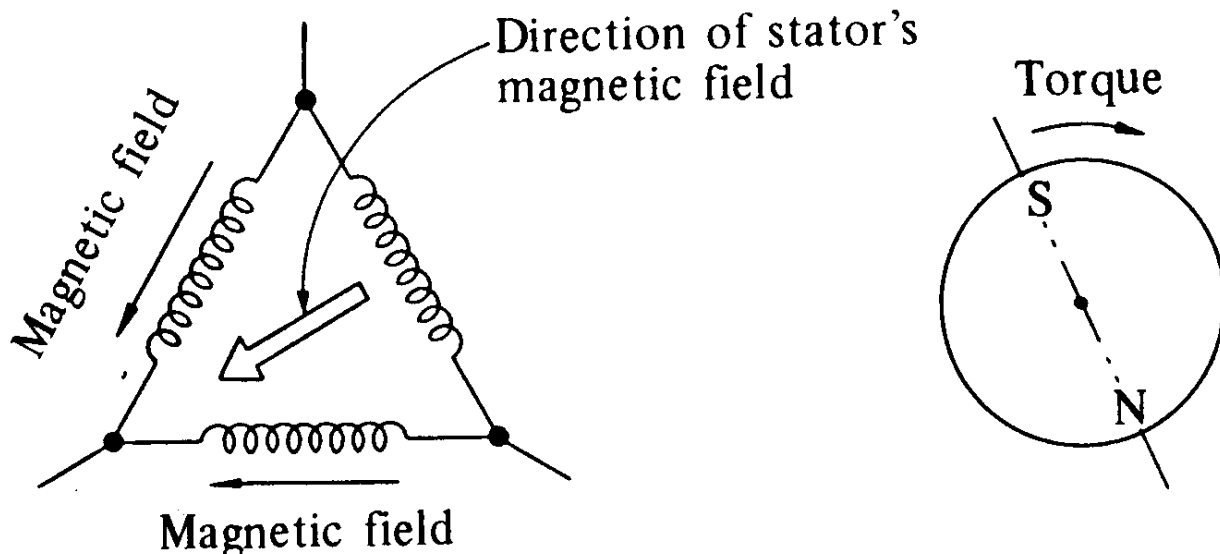

Figure 2.27: Stator's Magnetic Field in the Shutter State and Torque Direction

Tr 1	1	1	1	0	0	0
2	0	0	0	1	1	1
3	0	0	1	1	1	0
4	1	1	0	0	0	1
5	1	0	0	0	1	1
6	0	1	1	1	0	0

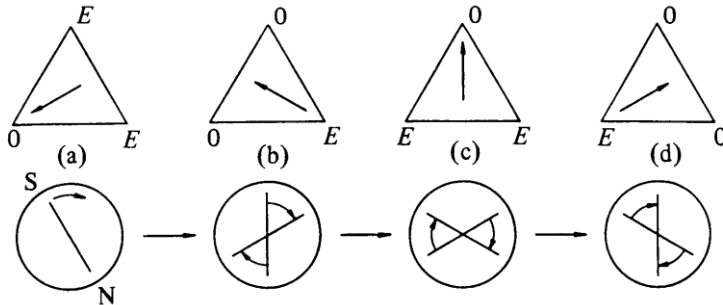

Figure 2.28: Clockwise Revolutions of the Stator's Magnetic Field and Rotor

The rotational direction may be reversed by arranging the logic sequencer in such a way that when a photodetector marked with a certain number is exposed to light, the transistor of the same number is turned OFF. On the other hand, when a phototransistor is not exposed to light, the transistor of the same number is turned ON. In the positional state of Figure 2.26, Tr2, 3, and 6 are ON, and the battery voltage E appears at terminal V, while U and W have zero electric potential. Then, as shown in Figure 2.29(a), the magnetic field in the stator is reversed, and the rotor's torque is counter-clockwise. After the motor revolves about 30°, Tr2 turns OFF and Tr1 ON. At this point, the field has revolved 60° and becomes as shown in (b). As the rotor produces another counterclockwise torque, the counter-clockwise motion continues and the field becomes as shown in (c). This action is replaced in the sequence of (a) to (b) to (c) to (d)..... to produce a continuous counter-clockwise motion.

ON-OFF sequence	1	2	3	4	5	6
Tr 1	0	1	1	1	0	0
2	1	0	0	0	1	1
3	1	1	0	0	0	1
4	0	0	1	1	1	0
5	0	0	0	1	1	1
6	1	1	1	0	0	0

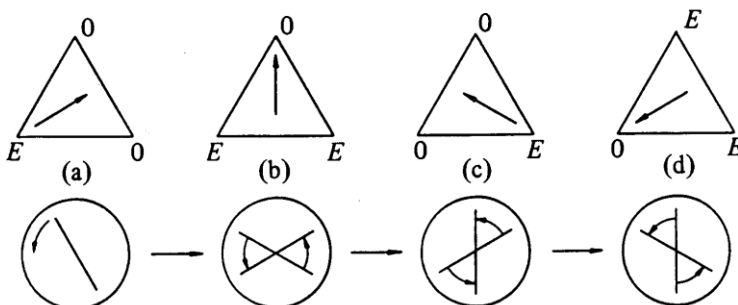

Figure 2.29: Counter Clockwise Revolutions of the Stator's Magnetic Field and Rotor

The motor discussed above has Δ -connected windings, but it may also have Y-connected windings.

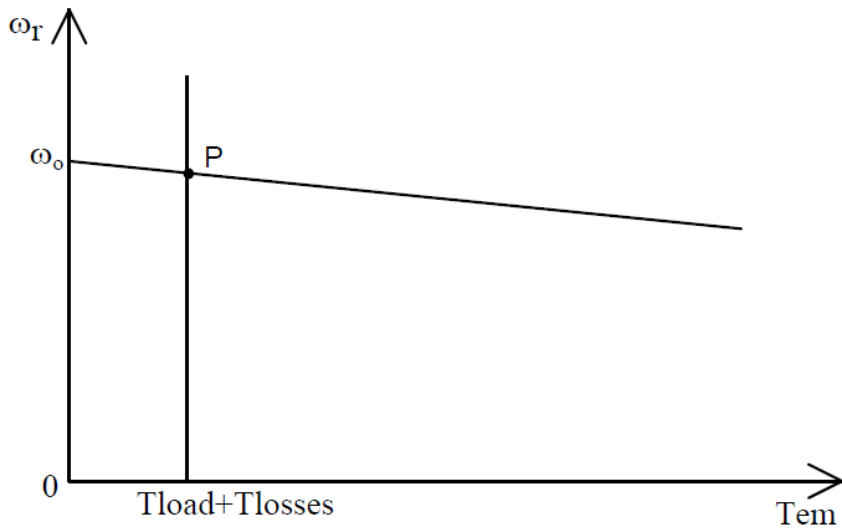

Figure 2.30: T- ω Curve of a Brushless DC Motor with a Constant Voltage Supply

Figure 2.30 shows the typical characteristics of Torque-Angular Velocity for a constant voltage supplied.

Electronic Speed Control:

An electronic speed control or ESC is an electronic circuit with the purpose to vary an electric motor's speed, its direction and possibly also to act as a dynamic brake. ESCs are often used on electrically powered radio controlled models, with the variety most often used for brushless motors essentially providing an electronically-generated three phase electric power low voltage source of energy for the motor. An ESC can be a stand-alone unit which plugs into the receiver's throttle control channel or incorporated into the receiver itself, as is the case in most toy-grade R/C vehicles. Some R/C manufacturers that install proprietary hobby-grade electronics in their entry-level vehicles, vessels or aircraft use onboard the electronics that combine the two on a single circuit board.

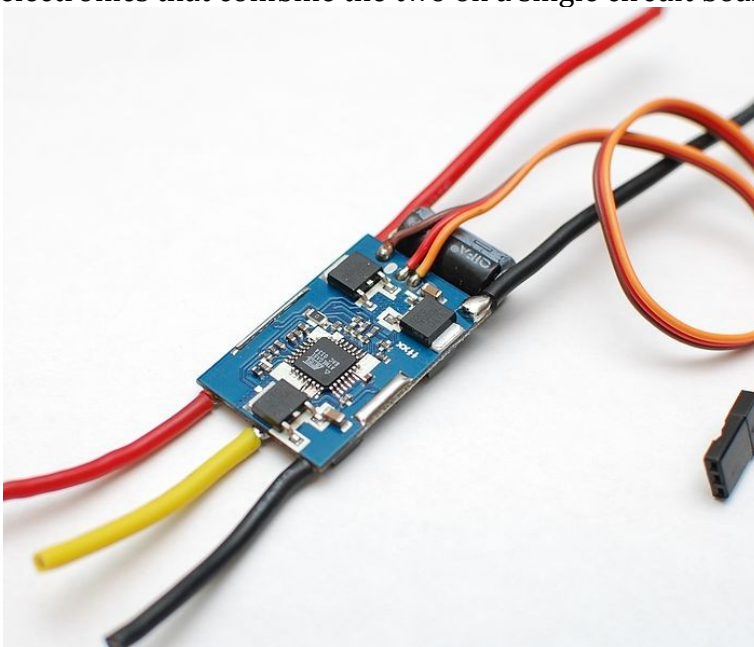

Figure 2.31: Electronic Speed Controller for a BLDC Motor

Function:

Regardless of the type used, an ESC interprets control information not as mechanical motion as would be the case of a servo, but rather in a way that varies the switching rate of a network of field effect transistors, or FETs. The rapid switching of the transistors is what causes the motor itself to emit its characteristic high-pitched whine, especially noticeable at lower speeds. It also allows much smoother and more precise variation of motor speed in a far more efficient manner than the mechanical type with a resistive coil and moving arm once in common use. Most modern ESCs incorporate a battery eliminator circuit (or BEC) to regulate voltage for the receiver, removing the need for receiver batteries. BECs are usually either linear or switched mode voltage regulators. DC ESCs in the broader sense are PWM controllers for electric motors. The ESC generally accepts a nominal 50 Hz PWM servo input signal whose pulse width varies from 1 ms to 2 ms. When supplied with a 1 ms width pulse at 50 Hz, the ESC responds by turning off the DC motor attached to its output. A 1.5 ms pulse-width input signal results in a 50% duty cycle output signal that drives the motor at approximately half-speed. When presented with 2.0 ms input signal, the motor runs at full speed due to the 100% duty cycle (on constantly) output. Brushless ESC systems basically drive tri-phase Brushless motors by sending sequence of signals for rotation. Brushless motors otherwise called outrunners or inrunners have become very popular with radio controlled airplane hobbyists because of their efficiency, power, longevity and light weight in comparison to traditional brushed motors. However, brushless DC motor controllers are much more complicated than brushed motor controllers. The correct phase varies with the motor rotation, which is to be taken into account by the ESC: Usually, back EMF from the motor is used to detect this rotation, but variations exist that use magnetic (Hall Effect) or optical detectors. Computer-programmable speed controls generally have a user-specified option which allows setting low voltage cut-off limits, timing, acceleration, braking and direction of rotation. Reversing the motor's direction may also be accomplished by switching any two of the three leads from the ESC to the motor.

For the Aerial Surveillance Unit we have used D2822/14 1450Kv BLDC Motor, D2208 20A BLDC Motor Controller and HQ 848A Propeller Blade.



Figure 2.32: BLDC Motor with ESC, D2822/14 1450Kv



Figure 2.33: HQ 848A Propeller Blade

Specifications:

- Model: D2822/14
- Weight: 38g
- Dimensions: 22 x 28
- Voltage: 7.2v~11.1v 2s~3s Lipoly
- Kv: 1450rpm/v
- Shaft: 3.17mm Diameter
- Max Watts: 160W
- Suggested Propeller: 8x6(2s) 7x4.5(3s)
- Shaft A (mm): 3.17
- Length B (mm): 22
- Diameter C (mm): 28
- Can Length D (mm): 10
- Total Length E (mm): 37

CHAPTER 3 - SYSTEM CONNECTIVITY AND OPERATION

3.1 CONNECTIVITY

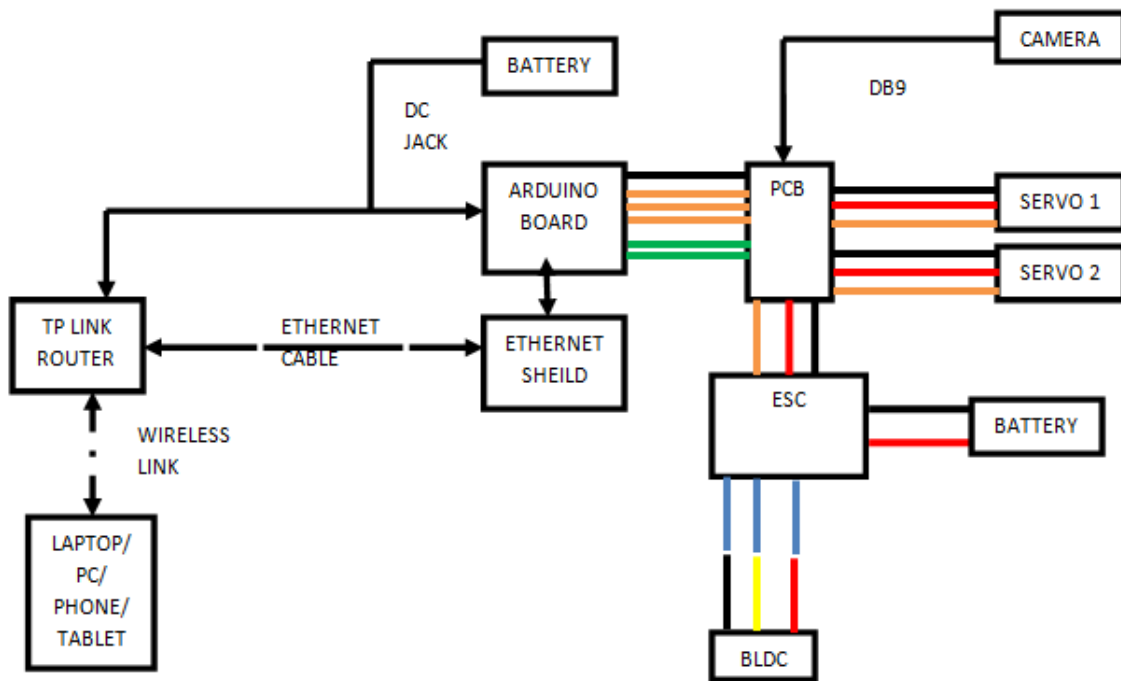

Figure 3.1: Simplified Connection Diagram

Figure 3.1 shows the simplified connection diagram for the Aerial Surveillance Unit. The detailed circuit schematic diagram is shown in Figure 3.2. The PCB layout is shown in Figure 3.3 and Figure 3.4. Figure 3.5 shows the testing phase for Arduino Board and Ethernet Shield with the other components using Fritzing.

Power Supply:

Arduino Board and TP Link Router powered by a 2.1mm center positive DC power jack. 9V is provided to both of them (2x Li-Poly Battery of 4.5V).

The Ethernet Shield receives power from the Arduino Board or via the Ethernet cable (PoE).

The BLDC Motor is connected to 13.5V via the ESC (Red +ve, Black -ve)

The camera and servos are powered via the 7805 regulator from the PCB.

Communication System:

The Ethernet Shield is directly placed on top of the Arduino Board, as shown in Figure 2.15.

Ethernet cable is connected to the Ethernet Shield via the RJ-45 port and the other end connected to the yellow colored LAN port of the TP Link Router, as shown in 2.16.

The TP Link Router is connected to the Remote Host Device via a secured wireless communication link.

Surveillance System:

The uCam-232 serial camera is connected to the PCB using DB9 connector cable.

The 2 green lines between Arduino Board and PCB are the Tx-Rx lines for the serial camera. They are connected to Pin 0 and Pin 1 of the Arduino Board. The black line indicates GND. The connection from the PCB to the Arduino Board is via connecting wires from J1, as shown in the schematic and PCB layout.

Locomotion System:

3 colored wires from the servo controller (both servo motor and ESC of BLDC) are connected to the PCB; Black (GND), Red (5V) and Orange (PWM SIGNAL).

The Orange lines between the Arduino Board and PCB are the control signal wires for the 2 servo motors and BLDC motor, they are connected to PWM pins of the Arduino Board. Servo 1 is connected to Pin 9, Servo 2 is connected to Pin 11 and Control for BLDC is connected to Pin 5.

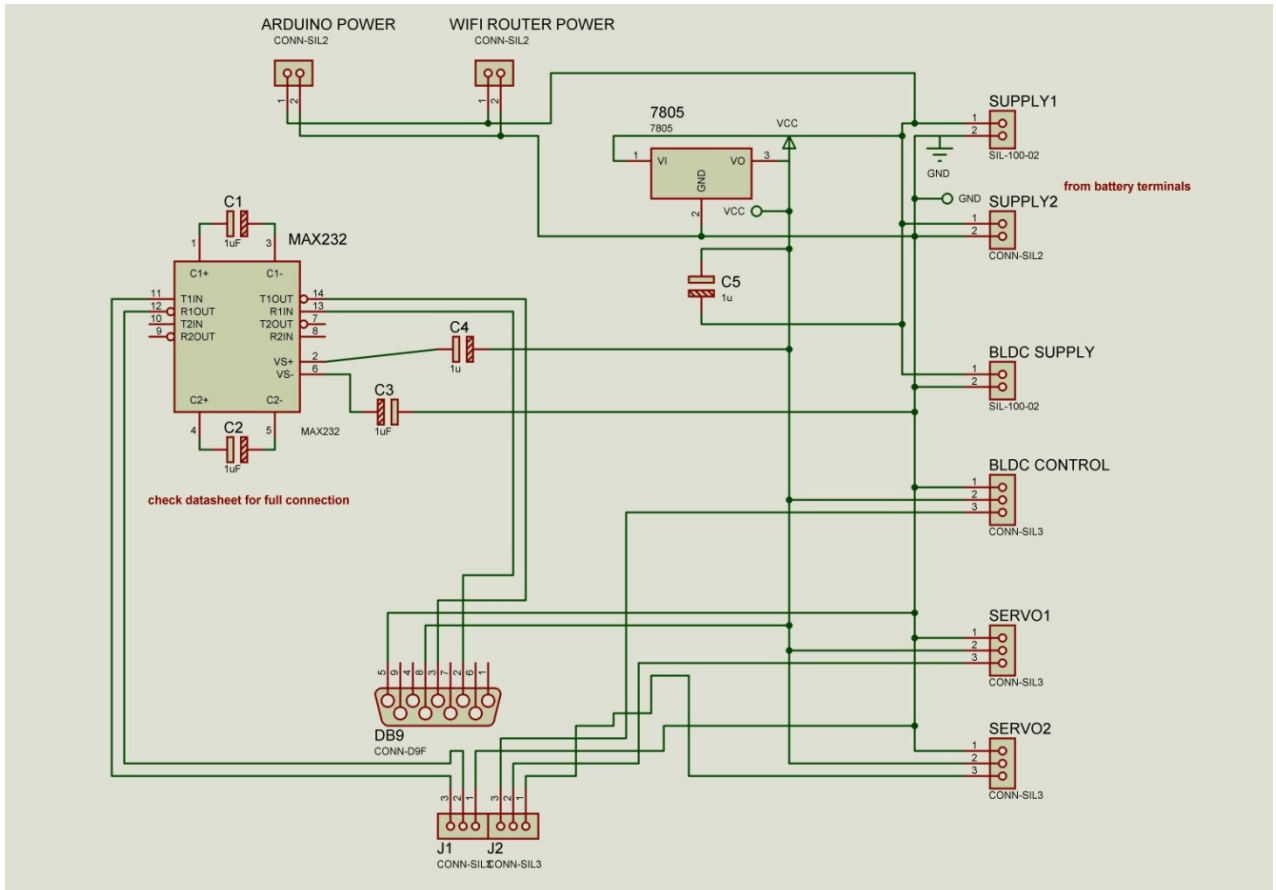

Figure 3.2: Schematic Diagram

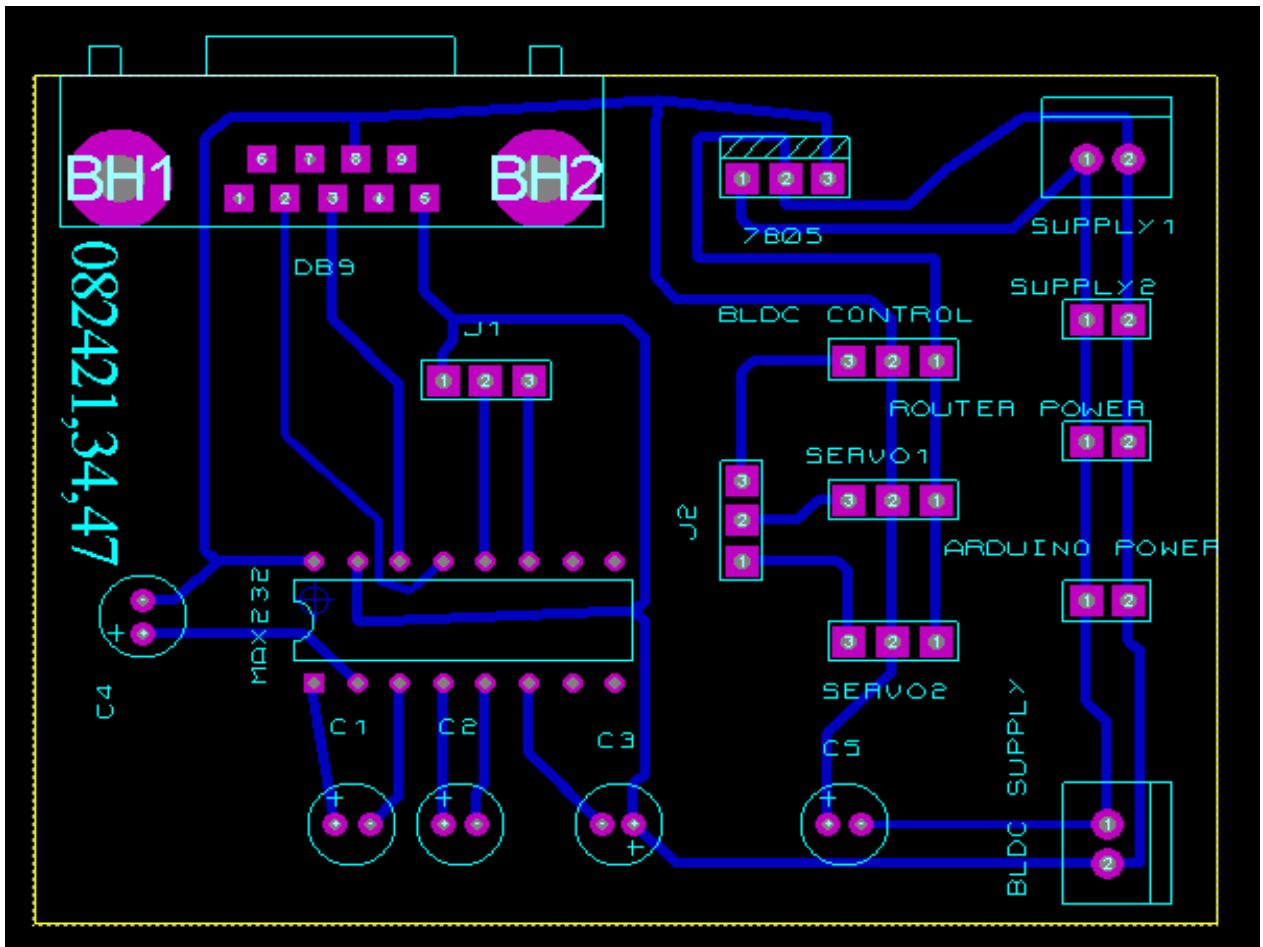

Figure 3.3: PCB Layout

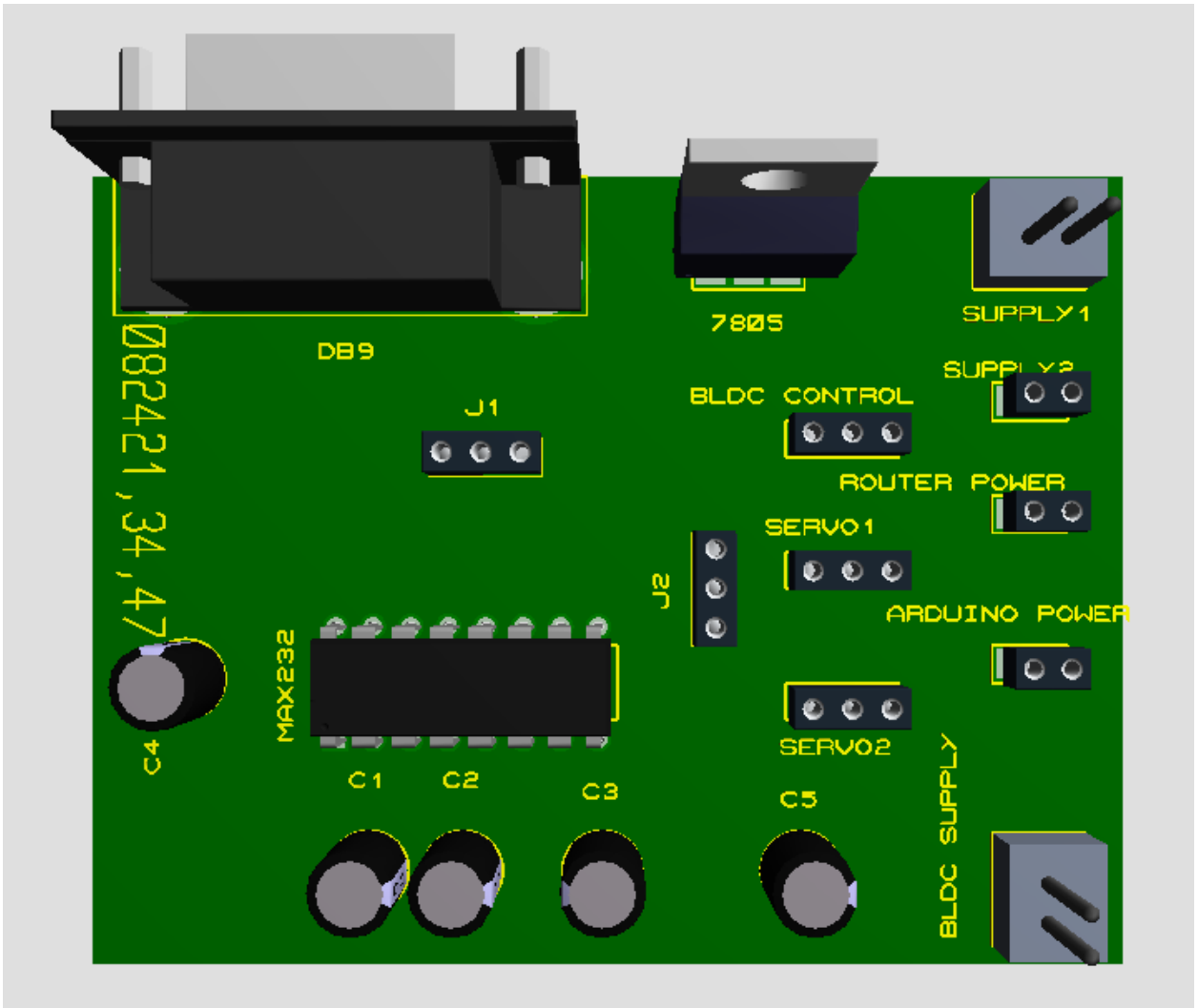

Figure 3.4: 3D Visualization For PCB Layout

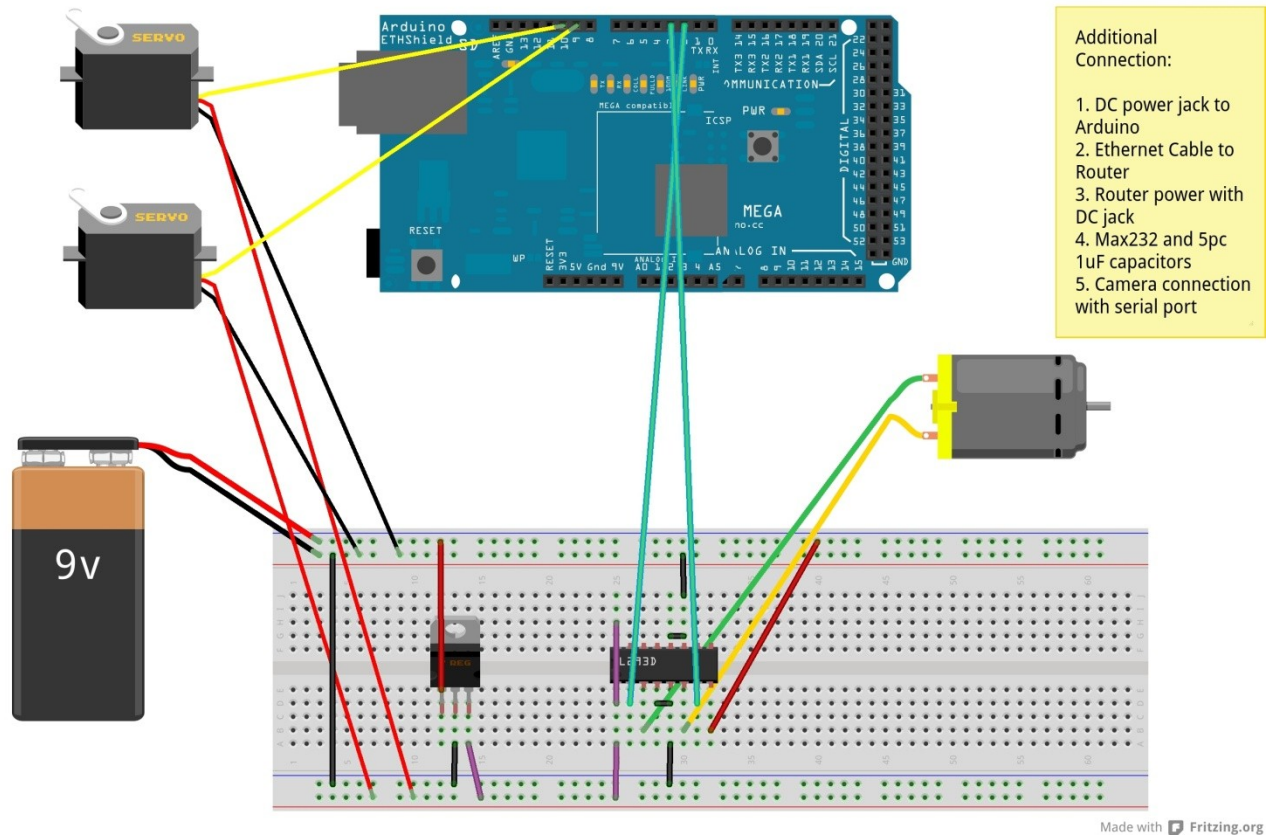

Figure 3.5: Testing with Arduino Board and Ethernet Shield using Fritzing

3.2 OPERATION

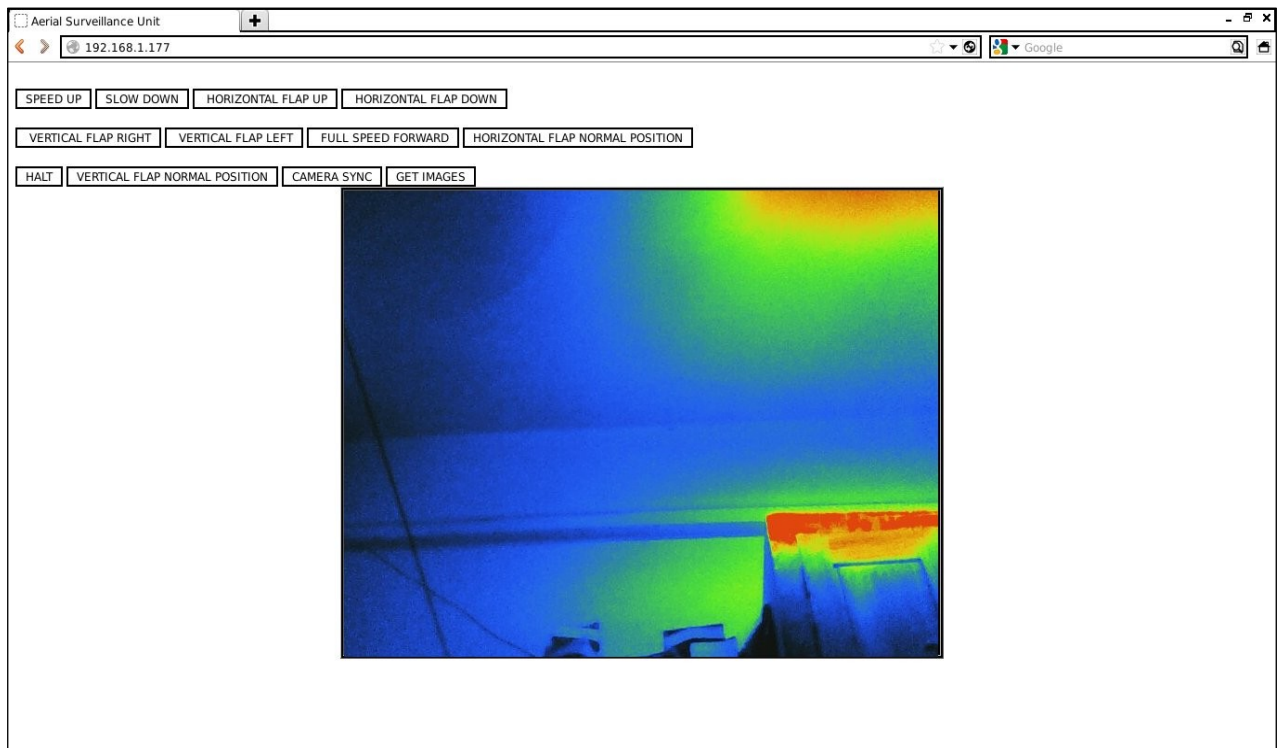

Figure 3.6: Screenshot for Web Based GUI

An HTML web server was created that was programmed into the Arduino Mega 2560. The code is a combination of C, JAVA and HTML. The Aerial Surveillance Unit can only be controlled using this web based GUI. MAC Address and IP Address has been assigned to Aerial Surveillance Unit by the program, it has an IP address of 192.162.1.177. The router is setup to route the web server in the Ethernet Shield bearing the above IP. The router has been configured to a certain SSID and password. For testing we had used SSID named, Aerial Surveillance Unit and authentication password, 1234567890 for the WEP security. In order to check for successful connectivity we can try to ping from the terminal, however this can only be done if we are using a Laptop for a remote host. After successful connection, we open any web browser application. On the address bar, we type the IP address for the HTML web server assigned to it by programming. Once the we connect using the web browser, an HTML page appears as shown in Figure 3.6.

Button Functions:

- SPEED UP: Increases the speed of BLDC motor in steps of 5, per click.
- SLOW DOWN: Decreases the speed of BLDC motor in steps of 5, per click.
- HORIZONTAL FLAP UP: Servo Motor 1 raises the Elevator.
- HORIZONTAL FLAP DOWN: Servo Motor 1 lowers the Elevator.
- VERTICAL FLAP RIGHT: Servo Motor 2 moves the Rudder to the Right
- VERTICAL FLAP LEFT: Servo Motor 2 moves the Rudder to the Left
- FULL SPEED FORWARD: BLDC motor runs with Maximum Speed
- HORIZONTAL FLAP NORMAL POSITION: Servo Motor 1 moves the Elevator to the normal position.
- HALT
- VERTICAL FLAP NORMAL POSITION: Servo Motor 2 moves the Rudder to the normal position.
- CAMERA SYNC: The camera begins the synchronizing process.
- GET IMAGES: Images are captured, compressed, saved to memory and sent to the remote host.

CHAPTER 4 - SOFTWARE AND PROGRAMMING

4.1 SOFTWARES USED

The CAD design, load study and motion study were prepared using SolidWorks 2011. The basic circuit schematic, simulation and PCB layout design were performed using Proteus Professional 7.10 (ISIS and ARES). Interfacing Arduino Mega 2560 with the other circuit components were simulated using Fritzing 0.7.7b. The control program was done using Arduino IDE 1.1. The camera was tested and simulated using uCamDemo-rev2.

4.2 PROGRAM PSEUDO CODE

```
#include<SPI.H>
#include<Ethernet.h>
#include<Servo.h>

//setup servos
Servo servo_horizontal;
Servo servo_vertical;
Servo bldc;
```

```

//define and initialize parameters required for ethernet server
byte mac[] = {_, _, _, ..... };
byte ip[] = {_, _, _, ..... };
EthernetServer server(80);

void setup()
{
    //assign pwm o/p pins for each servo
    servo_horizontal.attach(9);
    servo_vertical.attach(11);
    servo_bldc.attach(5);

    //start the Ethernet connection, server and serial
    Ethernet.begin(mac, ip);
    server.begin();
    Serial.begin(desired_baud_rate);
}

void loop()
{
    //check for client
    EthernetClient client = server.available();
    if(client)
    {
        while(client.connected())
        {
            if(client.available())
            {
                check_http_request;
                if (http_request)
                {
                    send_http_response_header;
                    client.println(complete_HTML_code);
                    client.println(along_with_javascript);
                    client.println(and XMLhttpObject);
                }
                else
                {
                    //using XMLHttpRequest access
                    if(SPEED UP_pressed) SPEED UP;
                    elseif(SLOW DOWN) SLOW DOWN;
                    elseif(HORIZONTAL FLAP UP) HORIZONTAL FLAP UP;
                    elseif(HORIZONTAL FLAP DOWN) HORIZONTAL FLAP DOWN;
                    elseif(VERTICAL FLAP RIGHT) VERTICAL FLAP RIGHT;
                    elseif(VERTICAL FLAP LEFT) VERTICAL FLAP LEFT;
                    elseif(FULL SPEED FORWARD) FULL SPEED FORWARD;
                    elseif(HORIZONTAL FLAP NORMAL POSITION) HORIZONTAL FLAP
NORMAL POSITION;

                    elseif(HALT) HALT;
                    elseif(VERTICAL FLAP NORMAL POSITION) VERTICAL FLAP NORMAL
POSITION;
                    elseif(CAMERA SYNC) CAMERA SYNC;
                    elseif(GET IMAGES) GET IMAGES;
                    else DO NOTHING;
                }
            }
        }
    }
    Client.stop();
}
}

```

4.3 FLOWCHART

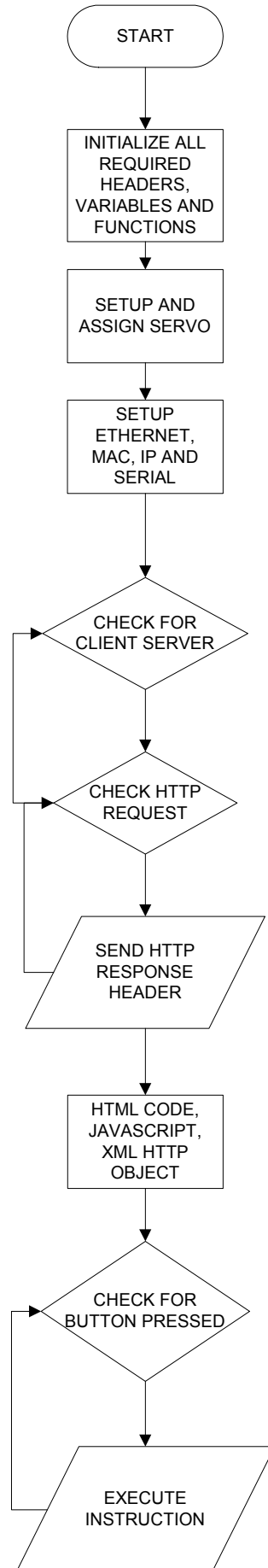

TROUBLESHOOTING

The complete system was implemented successfully but unfortunately we could not make the Aerial Surveillance Unit have its flight. There are scope for modifications in the design and decreasing the payload. Another disadvantage that we came across was that we did not have the facility to test it in a Wind Tunnel.

The batteries were draining out very quickly. Using higher wattage batteries would improve the condition. But we have to keep in check that the battery weight does not become too heavy.

Sometimes, the communication system would not connect. We tried to infer the reason behind it but could not get it. May be using a better communication scheme will make the system more reliable.

In the circuit there were 5 components that were being supplied 5V. The MAX232 IC, camera, 2 servos and the BLDC controller. This made the 7805 regulator too hot. Moreover, the maximum current rating had exceeded. Thus, switching regulators may be used for better performance.

Another difficulty that we encountered was the limitation of range due to the wifi device. For a more useful communication system, a scheme should be that selected that has good range and large bandwidth.

We had tried to control the unit through the internet by assigning the unit a real IP address and connected it to the global internet. But, we could not do that successfully due to some unknown reasons. This implementation will enable the unit to be controlled from anywhere in the world if there is internet access. However, we could successfully control the unit using the university network. We had tried to control the unit from a laptop at a different hall of residence and it worked.

FURTHER WORK

Additional features needs to be implemented in order to have a reliable system. GPS, accelerometers, pressure sensors and gyros should be added so that the Aerial Surveillance Unit has better control, navigation and positioning. IMUs or any smart phones can give all these features. Other sensors may be added according to the purpose. A camera with a better frame rate should be used. The system should be upgraded in order to use to it for traffic management, crime management, security purposes and pollution management especially in the context of Bangladesh.

CONCLUSION

The basic motive behind the implementation of Aerial Surveillance Unit is to pioneer the research of Aerial Surveillance and its various applications at the University and in Bangladesh. The successful implementation of the Aerial Surveillance Unit's communication system, locomotion system and surveillance system is in itself a great contribution. There are huge prospects and wide variety of applications for Aerial Surveillance. All throughout the world advanced developments have occurred in this field. A rapid rise of such commercial and civilian applications has been observed in the recent years. So lagging behind is not an option. Further modification in this system will make it a very reliable device. Important points that need to be considered are the improvement on the physical structure and design of the device, the addition of other vital components such as the gyros, GPS, pressure sensors and accelerometers, using IMUs or if feasible smart phones.

APPENDICES

APPENDIX A: Pin Mapping for Arduino Mega 2560

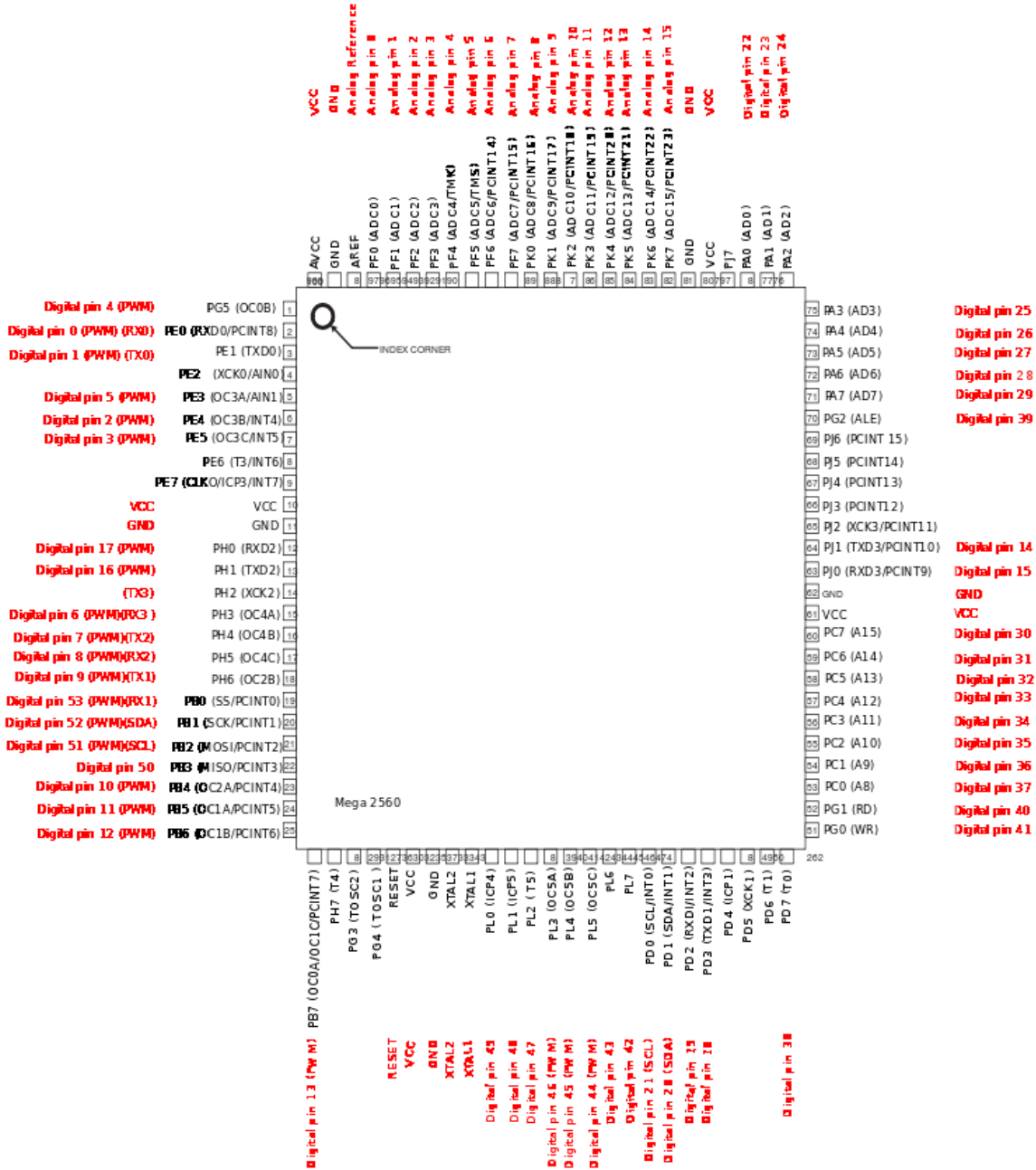

Figure A.1: Pin Diagram for Arduino Mega 2560

Pin Number	Pin Name	Mapped Pin Name
1	PG5 (OC0B)	Digital pin 4 (PWM)
2	PE0 (RXD0/PCINT8)	Digital pin 0 (PWM) (RX0)
3	PE1 (TXD0)	Digital pin 1 (PWM) (TX0)
4	PE2 (XCK0/AIN0)	
5	PE3 (OC3A/AIN1)	Digital pin 5 (PWM)
6	PE4 (OC3B/INT4)	Digital pin 2 (PWM)
7	PE5 (OC3C/INT5)	Digital pin 3 (PWM)
8	PE6 (T3/INT6)	
9	PE7 (CLK0/ICP3/INT7)	
10	VCC	VCC
11	GND	GND
12	PH0 (RXD2)	Digital pin 17 (PWM)
13	PH1 (TXD2)	Digital pin 16 (PWM)
14	PH2 (XCK2)	(TX3)
15	PH3 (OC4A)	Digital pin 6 (PWM)(RX3)
16	PH4 (OC4B)	Digital pin 7 (PWM)(TX2)
17	PH5 (OC4C)	Digital pin 8 (PWM)(RX2)
18	PH6 (OC2B)	Digital pin 9 (PWM)(TX1)
19	PB0 (SS/PCINT0)	Digital pin 53 (PWM)(RX1)
20	PB1 (SCK/PCINT1)	Digital pin 52 (PWM)(SDA)
21	PB2 (MOSI/PCINT2)	Digital pin 51 (PWM)(SCL)
22	PB3 (MISO/PCINT3)	Digital pin 50
23	PB4 (OC2A/PCINT4)	Digital pin 10 (PWM)
24	PB5 (OC1A/PCINT5)	Digital pin 11 (PWM)
25	PB6 (OC1B/PCINT6)	Digital pin 12 (PWM)
26	PB7 (OC0A/OC1C/PCINT7)	Digital pin 13 (PWM)
27	PH7 (T4)	
28	PG3 (TOSC2)	
29	PG4 (TOSC1)	
30	RESET	RESET
31	VCC	VCC
32	GND	GND
33	XTAL2	XTAL2
34	XTAL1	XTAL1
35	PL0 (ICP4)	Digital pin 49
36	PL1 (ICP5)	Digital pin 48
37	PL2 (T5)	Digital pin 47
38	PL3 (OC5A)	Digital pin 46 (PWM)
39	PL4 (OC5B)	Digital pin 45 (PWM)
40	PL5 (OC5C)	Digital pin 44 (PWM)
41	PL6	Digital pin 43
42	PL7	Digital pin 42
43	PD0 (SCL/INT0)	Digital pin 21 (SCL)

44	PD1 (SDA/INT1)	Digital pin 20 (SDA)
45	PD2 (RXD1/INT2)	Digital pin 19
46	PD3 (TXD1/INT3)	Digital pin 18
47	PD4 (ICP1)	
48	PD5 (XCK1)	
49	PD6 (T1)	
50	PD7 (T0)	Digital pin 38
51	PG0 (WR)	Digital pin 41
52	PG1 (RD)	Digital pin 40
53	PC0 (A8)	Digital pin 37
54	PC1 (A9)	Digital pin 36
55	PC2 (A10)	Digital pin 35
56	PC3 (A11)	Digital pin 34
57	PC4 (A12)	Digital pin 33
58	PC5 (A13)	Digital pin 32
59	PC6 (A14)	Digital pin 31
60	PC7 (A15)	Digital pin 30
61	VCC	VCC
62	GND	GND
63	PJ0 (RXD3/PCINT9)	Digital pin 15
64	PJ1 (TXD3/PCINT10)	Digital pin 14
65	PJ2 (XCK3/PCINT11)	
66	PJ3 (PCINT12)	
67	PJ4 (PCINT13)	
68	PJ5 (PCINT14)	
69	PJ6 (PCINT 15)	
70	PG2 (ALE)	Digital pin 39
71	PA7 (AD7)	Digital pin 29
72	PA6 (AD6)	Digital pin 28
73	PA5 (AD5)	Digital pin 27
74	PA4 (AD4)	Digital pin 26
75	PA3 (AD3)	Digital pin 25
76	PA2 (AD2)	Digital pin 24
77	PA1 (AD1)	Digital pin 23
78	PA0 (AD0)	Digital pin 22
79	PJ7	
80	VCC	VCC
81	GND	GND
82	PK7 (ADC15/PCINT23)	Analog pin 15
83	PK6 (ADC14/PCINT22)	Analog pin 14
84	PK5 (ADC13/PCINT21)	Analog pin 13
85	PK4 (ADC12/PCINT20)	Analog pin 12
86	PK3 (ADC11/PCINT19)	Analog pin 11
87	PK2 (ADC10/PCINT18)	Analog pin 10
88	PK1 (ADC9/PCINT17)	Analog pin 9

89	PK0 (ADC8/PCINT16)	Analog pin 8
90	PF7 (ADC7/PCINT15)	Analog pin 7
91	PF6 (ADC6/PCINT14)	Analog pin 6
92	PF5 (ADC5/TMS)	Analog pin 5
93	PF4 (ADC4/TMK)	Analog pin 4
94	PF3 (ADC3)	Analog pin 3
95	PF2 (ADC2)	Analog pin 2
96	PF1 (ADC1)	Analog pin 1
97	PF0 (ADC0)	Analog pin 0
98	AREF	Analog Reference
99	GND	GND
100	AVCC	VCC

Table A.1: Pin Mapping for Arduino Mega 2560

APPENDIX B: TL-WR340GD SPECIFICATIONS

HARDWARE FEATURES	
Interface	4 10/100Mbps LAN Ports 1 10/100Mbps WAN Port
Button	Reset Button
External Power Supply	9VDC/0.6A
Wireless Standards	IEEE 802.11g, IEEE 802.11b
Antenna	5dBi Detachable Omni-Directional (RP-SMA)
Dimensions (W x D x H)	6.3 x 4.2 x 1.2 in. (160 x 102 x 28mm)

Table B.1: Hardware Features

WIRELESS FEATURES	
Frequency	2.4-2.4835GHz
Signal Rate	11g: Up to 54Mbps(dynamic) 11b: Up to 11Mbps(dynamic)
EIRP	<20dBm(EIRP)
Reception Sensitivity	54M: -68dBm@10% PER 11M: -85dBm@8% PER 6M: -88dBm@10% PER 1M: -90dBm@8% PER
Wireless Functions	Enable/Disable Wireless Radio, WDS Bridge
Wireless Security	64/128/152-bit WEP / WPA / WPA2,WPA-PSK / WPA2-PSK

Table B.2: Wireless Features

SOFTWARE FEATURES	
WAN Type	Dynamic IP/Static IP/PPPoE/ PPTP(Dual Access)/L2TP(Dual Access)/BigPond
DHCP	Server, Client, DHCP Client List, Address Reservation
Port Forwarding	Virtual Server,Port Triggering, UPnP, DMZ
Dynamic DNS	DynDns, Comexe, PeanutHull
VPN Pass-Through	PPTP, L2TP, IPSec (ESP Head)
Access Control	Parental Control, Local Management Control, Host List, Access Schedule, Rule Management
Firewall Security	DoS, SPI Firewall IP Address Filter/MAC Address Filter/Domain Filter IP and MAC Address Binding
Management	Access Control Local Management Remote Management

Table B.3: Software Features

REFERENCES

- [1] Kong Wai Weng; Abidin, M.S.B.; , "Design and Control of a Quad-Rotor Flying Robot For Aerial surveillance," Research and Development, 2006. SCORED 2006. 4th Student Conference on , vol., o., pp.173-177, 27-28 June 2006, doi: 10.1109/SCORED.2006.4339333, URL: <http://ieeexplore.ieee.org/stamp/stamp.jsp?tp=&arnumber=4339333&isnumber=4339288>
- [2] Pauli Rudolf H. Schlidt et al, "TETHERED HOVERING PLATFORM FOR AERIAL SURVEILLANCE", Patent number: 3217097, Filing date: Aug 9, 1961, Issue date: Nov 9, 1965
- [3] William L. Allan et al, "AERIAL SURVEILLANCE AND FIRE- CONTROL SYSTEM", Patent number: 3715953, Filing date: Feb 4, 1966, Issue date: Feb 3, 1973
- [4] Robertson, P.; Brady, J.M.; , "Adaptive image analysis for aerial surveillance," Intelligent Systems and their Applications, IEEE , vol.14, no.3, pp.30-36, May/Jun 1999, doi: 10.1109/5254.769882, URL: <http://ieeexplore.ieee.org/stamp/stamp.jsp?tp=&arnumber=769882&isnumber=16695>
- [5] Beard, R.W.; McLain, T.W.; Nelson, D.B.; Kingston, D.; Johanson, D.; , "Decentralized Cooperative Aerial Surveillance Using Fixed-Wing Miniature UAVs," Proceedings of the IEEE , vol.94, no.7, pp.1306-1324, July 2006, doi: 10.1109/JPROC.2006.876930, URL: <http://ieeexplore.ieee.org/stamp/stamp.jsp?tp=&arnumber=1677946&isnumber=35292>
- [6] Jong-Hann Jean; Jian-Hong Lai; , "Design and implementation of a visual servo system for aerial surveillance applications based on shape features," Mechatronics, 2005. ICM '05. IEEE International Conference on , vol., no., pp.416-421, 10-12 July 2005, doi: 10.1109/ICMECH.2005.1529293, URL: <http://ieeexplore.ieee.org/stamp/stamp.jsp?tp=&arnumber=1529293&isnumber=32633>
- [7] Kumar, R.; Sawhney, H.; Samarasekera, S.; Hsu, S.; Hai Tao; Yanlin Guo; Hanna, K.; Pope, A.; Wildes, R.; Hirvonen, D.; Hansen, M.; Burt, P.; , "Aerial video surveillance and exploitation," Proceedings of the IEEE , vol.89, no.10, pp.1518-1539, Oct 2001, doi: 10.1109/5.959344, URL: <http://ieeexplore.ieee.org/stamp/stamp.jsp?tp=&arnumber=959344&isnumber=20732>
- [8] Edison Pignaton de Freitas, Armando Morado Ferreira, Carlos Eduardo Pereira and Tony Larsson, "Middleware Support in Unmanned Aerial Vehicles and Wireless Sensor Networks for Surveillance Applications", Studies in Computational Intelligence, 2009, Volume 237/2009, 289-296, DOI: 10.1007/978-3-642-03214-1_33
- [9] A Rowe, C Rosenberg, I Nourbakhsh, " CMUcam: a lowoverhead vision system", Proceedings, IROS 2002, 2002

- [10] J. Orlando, "AVRcam A Low-Cost Embedded Vision System", Circuit cellar: The magazine for computer applications, ISSN 1528-0608, 2005, pages. 12-19
- [11] Hintermaier, W.; Steinbach, E.; , "A system architecture for IP-camera based driver assistance applications," Intelligent Vehicles Symposium (IV), 2010 IEEE , vol., no., pp.540-547, 21-24 June 2010, doi: 10.1109/IVS.2010.5548103, URL: <http://ieeexplore.ieee.org/stamp/stamp.jsp?tp=&arnumber=5548103&isnumber=5547951>
- [12] Wu-Chih Hu, Deng-Yuan Huang, Wei-Hao Chen, "ADAPTIVE WIDE FIELD-OF-VIEW SURVEILLANCE BASED ON AN IP CAMERA ON A ROTATIONAL PLATFORM FOR AUTOMATIC DETECTION OF ABANDONED AND REMOVED OBJECTS", ICIC Express Letters, Part B: Applications, ICIC International c 2010 ISSN 2185-2766, Volume 1, Number 1, September 2010, pp. 45-50
- [13] Grove - Serial Camera, URL: http://www.seedstudio.com/depot/grove-serial-camera-p-945.html?cPath=144_152
- [14] uCam-232, URL: www.4dsystems.com.au/prod.php?id=75
- [15] JG Andrews, A Ghosh, R Muhamed, "Fundamentals of WiMAX: understanding broadband wireless networking", 2007 ,Prentice Hall PTR
- [16] K Finkenzeller, Chippenham, "Radio-frequency identification fundamentals and applications", John Wiley & Son, 1999
- [17] ZigBee/802.15. 4 OEM RF Modules by MaxStream, OEM XBEE - Inc. Specifications
- [18] C Lennard, D Lin, K Ho, V Chandran, "Collaborative Development of Bluetooth IP: Fundamentals of System-Modeling in Complex IP Creation and Reuse" - Proceedings of IP 2000 Bluetooth Conference, 2000
- [19] Wi-Fi Protected Access: Strong, standards-based, interoperable security for today's Wi-Fi networks WF Alliance - Retrieved March, 2003 - ans-vb.com
- [20] Ferro, E.; Potorti, F.; , "Bluetooth and Wi-Fi wireless protocols: a survey and a comparison," Wireless Communications, IEEE , vol.12, no.1, pp. 12- 26, Feb. 2005, doi: 10.1109/MWC.2005.1404569, URL: <http://ieeexplore.ieee.org/stamp/stamp.jsp?tp=&arnumber=1404569&isnumber=30466>
- [21] 2560 A Mega - Arduino. Saatavissa: <http://arduino.cc/en/Main/> ..., 2012
- [22] T Igoe, " Making Things Talk: Using Sensors, Networks, and Arduino to see, hear, and feel your world", O'Reilly, 2011
- [23] Jonathan Oser, Hugh Blemings, "Practical Arduino: Cool Projects for Open Source Hardware", Apress, 2009

- [24] Gulati, H.; Vaishya, S.; Veeramachaneni, S.; , "Bluetooth and Wi-Fi controlled rescue robots," India Conference (INDICON), 2011 Annual IEEE , vol., no., pp.1-5, 16-18 Dec. 2011, doi: 10.1109/INDICON.2011.6139500, URL: <http://ieeexplore.ieee.org/stamp/stamp.jsp?tp=&arnumber=6139500&isnumber=6139311>
- [25] Ohishi, Kiyoshi; Nakao, Masato; Ohnishi, Kouhei; Miyachi, Kunio; , "Microprocessor-Controlled DC Motor for Load-Insensitive Position Servo System," Industrial Electronics, IEEE Transactions on , vol.IE-34, no.1, pp.44-49, Feb. 1987, doi: 10.1109/TIE.1987.350923, URL: <http://ieeexplore.ieee.org/stamp/stamp.jsp?tp=&arnumber=4158825&isnumber=4158814>
- [26] Kusko, A.; Peeran, S.M.; , "Definition of the brushless DC motor," Industry Applications Society Annual Meeting, 1988., Conference Record of the 1988 IEEE , vol., no., pp.20-22 vol.1, 2-7 Oct. 1988, doi: 10.1109/IAS.1988.25036, URL: <http://ieeexplore.ieee.org/stamp/stamp.jsp?tp=&arnumber=25036&isnumber=952>
- [27] Miller, T.J.E, "Brushless permanent-magnet and reluctance motor drives", ISBN: 0-19-859369-4, Oxford University Press, 1989