Quick Handover in LTE for High-Speed Metro Rails and Highways using PN Sequence Detection and Forward Handover

by

Md. Atiqul Haque

160021010

Kazi Md. Abir Hassan

160021022

Sakif Ahmed

160021028

A Thesis Submitted to the Academic Faculty in Partial Fulfillment of the Requirements for the Degree of

BACHELOR OF SCIENCE IN ELECTRICAL AND ELECTRONIC ENGINEERING

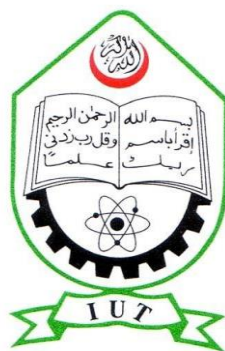

Department of Electrical and Electronic Engineering
Islamic University of Technology (IUT)
Gazipur, Bangladesh

March, 2021

A Dissertation on
Quick Handover in LTE for High-Speed Metro Rails and
Highways using PN Sequence Detection and Forward Handover

Approved by:

Dr. Mohammad Tawhid Kawser

Supervisor and Professor,
Department of Electrical and Electronic Engineering,
Islamic University of Technology (IUT),
Board Bazar, Gazipur-1704.

Date:

Table of Contents

List of Tables	v
List of Figures	vi
List of Acronyms	vii
Acknowledgements	ix
Abstract	x
1 Introduction	1
1.1 INTRODUCTION	1
1.2 FRAMEWORK AND INSPIRATION	
1.3 THESIS OUTLINE	3
2 Synopsis of LTE Technology and Network Architecture	4
2.1 INTRODUCTION	4
2.2 LTE-ADVANCED PRO OVERVIEW	4
2.3 NETWORK ARCHITECTURE.....	6
3 Mobility Management (MM) in LTE	9
3.1 INTRODUCTION	9
3.2 RADIO RESOURCE CONTROL (RRC) STATES	9
3.3 CELL RESELECTION	10
3.4 HANDOVER	11
3.4.1 <i>Measurement Reporting</i>	11
3.4.2 <i>Handover Parameters</i>	14
3.4.3 <i>Classification of Handover Procedure</i>	15
4 Challenges Encountered in High-Speed Environment	18
4.1 INTRODUCTION	18
4.2 ADJUSTMENT FOR SPEEDY UES	18
4.2.1 <i>Adjustment for Normal or Medium Mobility State UEs</i>	19
4.2.2 <i>Adjustment High-Mobility State UEs</i>	19
4.3 ALTERNATIVE SCHEME.....	20
5 Proposed Handover Scheme	21
5.1 INTRODUCTION	21
5.2 PREREQUISITE TECHNIQUES.....	21
5.2.1 <i>Contention Based Random Access Procedure</i>	21
5.2.2 <i>Forward Handover</i>	22
5.2.3 <i>Comparing Forward Handover with Backward Handover</i>	23
5.2.4 <i>PN Code Sequence</i>	25
5.2.5 <i>Additional Bandwidth</i>	27
5.3 HANDOVER SCHEME	29
5.4 TAKING CARE OF SOME CRITICAL PARAMETERS	33
5.5 SAMPLE CALCULATION.....	36
6 Simulation for The Proposed Quick Handover Scheme	38

6.1	INTRODUCTION	38
6.2	SIMULATION PARAMETERS	38
6.3	SIMULATION SCENARIO	38
6.4	SIMULATION RESULTS	40
7	Conclusion	43
	References	44

List of Tables

Table 5-1	Example of short code for identifying eNB.....	27
Table 5-2	Example of long code repetition cycle by cycle.....	27
Table 5-3	Modifications Required in RRCConnectionReconfiguration Message.....	32
Table 5-4	Usual Handover Procedure vs. Proposed Handover Procedure.....	33
Table 6-1	Assumed Parameters for Simulation.....	39

List of Figures

Figure 2.1: LTE Roadmap	4
Figure 2.2: Throughput comparison among LTE, LTE-A and LTE-A Pro.....	5
Figure 2.3: Comparison among LTE, LTE-A and LTE-A Pro in Terms of Bandwidth and Spectral Efficiency.....	6
Figure 2.4: Simple LTE Network architecture	7
Figure 3.1: Basic LTE Backward Handover Procedure	16
Figure 5.1: Contention Based Random Access Procedure Sequence	22
Figure 5.2: Forward Handover Procedure	23
Figure 5.3: Backward Handover Procedure.....	24
Figure 5.4: Time Requirement for each type of handover [30]	24
Figure 5.5: PN Sequence Generation.....	25
Figure 5.6: Combining data signal with PN sequence.....	26
Figure 5.7: Guard Band	28
Figure 5.8: Guard Band in LTE.....	28
Figure 5.9: Proposed Handover Scheme.....	31
Figure 5.10: Sequence of Proposed Handover Scheme.....	34
Figure 5.11: Operation sequence with respect to code length for the proposed HO Scheme.	37
Figure 6.1: UE transmit power vs. distance from eNB of one cell as the UE moves to another cell.....	40
Figure 6.2: P_{R_Min} vs. user speed for handover	41
Figure 6.3: Handover delay vs. user speed for handover.....	42

List of Acronyms

3GPP	3 rd Generation Partnership Project
4G	4 th Generation
5G	5 th Generation
5G-NR	5G New Radio
ACK	Positive Acknowledgement
CDMA	Code Division Multiple Access
DeNB	Donor enhanced NodeB
DL	Downlink
DS-CDMA	Direct Sequence Code Division Multiple Access
DSSS	Direct Sequence Spread Spectrum
EIRP	Effective Isotropic Radiated Power
eNB	Enhanced NodeB
EPC	Evolved Packet Core
EPS	Evolved Packet System
E-UTRAN	Evolved UMTS Terrestrial Radio Access
FDD	Frequency-Division Duplexing
GPS	Global Positioning System
GSM	Global System for Mobile Communications
HO	Handover
HetNet	Heterogeneous Network
HSPA	High-Speed Packet Access
LSFR	Linear Feedback Shift Register
LTE	Long Term Evolution
LTE-A	Long Term Evolution-Advanced
LHHAARC	LTE Hard Handover Algorithm with Average Received Signal Reference Power Constraint
MCS	Modulation and Coding Scheme
MEN-NEMO	Multiple Egress Network – Network Mobility
NACK	Negative Acknowledgement
NB-IOT	Narrow Band-Internet of Things
PDCCH	Physical Downlink Control Channel
PDN	Packet Data Network

PDSCH	Physical Downlink Shared Channel
P-GW	Packet Data Network Gateway
PL	Path Loss
PN	Reference Signal Received Power
PRB	Physical Resource Block
PRN	Pseudo Random Noise
PSD	Power Spectral Density
PUSCH	Physical Uplink Shared Channel
QoS	Quality of Service
RACH	Random Access Channel
RAN	Radio Access Network
RAP	Random Access Procedure
RAR	Random Access Response
RB	Resource Block
RLF	Radio Link Failure
RRC	Radio Resource Control
RRM	Radio Resource Management
RSRP	Reference Signal Received Power
RSRQ	Reference Signal Received Quality
SAE	System Architecture Evolution
S-GW	Serving Gateway
SINR	Signal-to-Interference-and-Noise Ratio
SNR	Signal-to-Noise Ratio
Smart-HO	Smart-Handover
SON	Self-Organizing Network
SSDT	Site Selection Diversity Transmission
TDD	Time-Division Duplexing
TF	Transport Format
TPC	Transmit Power Control
TTI	Time Transmission Interval
TTT	Time to Trigger
UE	User Equipment
UL	Uplink
UMTS	Universal Mobile Telecommunication System

Acknowledgements

First and foremost, we offer our gratitude to the Almighty Allah (SWT) for giving us the capability to do this work with good health. This thesis is a result of research of eight months and this is by far the most significant scientific accomplishment in our life.

We are grateful to our research supervisor, Professor Dr. Mohammad Tawhid Kawser for the support and continuous guidance throughout the course of this work. He created a research environment for which we were able to explore many ideas without constraint. We have gained a wealth of knowledge and experience in science and engineering through his direction that is beyond value to our future endeavors.

And last but not the least we are thankful to our family, friends and well-wishers for their support and inspiration. Without them it would never have been possible for us to make it this far.

Md. Atiqul Haque

Kazi Md. Abir Hassan

Sakif Ahmed

Abstract

Major evolution in high-speed railway and other motorized vehicular transportation systems demand equally adaptive technologies in cellular network communication. However, the high-speed of the vehicles present certain challenges with cellular communication. The existing standard protocol for high-speed mobility environment uses certain parameters to handle these challenges. However, they are not sufficient yet. As a result, high-speed vehicle users suffer from ping-pong handover and radio link failure, resulting in poor radio link quality. This paper proposes a forward handover technique combined with PN sequence detection to facilitate a quick handover capable of supporting high-speed mobility in metro rails and highways. The PN sequence keeps track of the UE location and helps set up a time synchronized handover procedure. The simulation results show a significant reduction in overall handover delay at the expense of slightly more complex implementation.

Chapter 1

Introduction

1.1 Introduction

The framework and inspiration for this thesis work and research purpose, are discussed in this chapter.

1.2 Framework and Inspiration

In the modern world, rapid developments of high-speed metro railway & highway communication systems almost globally demand higher adaptive requirements for cellular network communication throughout those transport systems. In the RRC_CONNECTED state, the UE mobility is supported through handover between eNodeBs [1]. For users moving at slow or moderate speed some parameters and protocols are followed to efficiently complete the handover procedure. These parameters include *TimeToTrigger* (TTT), hysteresis and triggering events. Such parameters are in place to avoid ping-pong effect in handover. But high-speed mobility users pass the cell boundary before the parameters are triggered to initiate the handover procedure. This results in further ping-pong handovers and *Radio Link Failures* (RLF). Thus, the necessity of handover procedures capable of adapting to the high-speed mobility arises. There has been a significant amount of work done to make the handover faster and more efficient.

The mobile relay technique has recently been discussed as a way to sustain connectivity networks for high-speed rail in *Long-Term Evolution Advanced* (LTE-A). Mobile relays struggle with regular handovers between serving donor eNodeBs (DeNBs) in case of high-speed rails. A cell array-based solution that smartly organizes cells along a railway was suggested. The cell array predicts the upcoming LTE cells in service and facilitates a seamless handover [2]. The authors of [3] – [6] proposes different adaptive hysteresis schemes based on cost function that takes into account some important aspects of the mobile relay, such as cell load, relay speed, and the requested service category by the UE. The authors of [7] presents a HetNets-based scheme for scaling cell switching parameters that integrate Doppler spread estimation and adjust to changes seamlessly. Both the eNodeB and the UE are involved in a

flexible scaling control. The specification of the long-term evolution (LTE) supports hard handover procedures. The authors of [8] tries to determine the failure rate of hard handover defined by 3GPP for LTE networks under different high speed and traffic load environments. There have been a large number of works to improve the hard handover process defined by LTE specifications. Algorithms using mobility trends attempt to create a mobility record to determine the predicted UE movement across the network. They search for the eligible cells for the handover in this way as well [9] – [10]. The authors of [11] suggests using a smart mobility pattern recognition handover, known as Smart-HO. The authors of [12] proposes a statistics-based handover optimization algorithm that takes into account reference signal received power (RSRP), reference signal received quality (RSRQ), and the rate at which cell resources vary. The authors of [13] discusses a neighbor cell list management technique that prioritized newly detected cells over the serving cells. Algorithms based on the UE location uses previous reference locations to predict the moving direction of the UE. Suitable target eNBs are determined by estimating the UE direction with cosine function. Thus, reducing unnecessary handovers [14] - [15]. The authors of [16] presents self-optimization mechanism as part of Self-Organizing Network (SON) based on cell ID information such as the number of handovers performed by the UE. The signal strength is used as the criteria while selecting the target cell. Many of the studies suggest modifying the traditional network architectonics or implementing a separate handover type than the hard handover used in LTE. The authors of [17] proposes a soft handover for TD-LTE in high-speed rail pursuing consistent radio link quality as well as reduced number of handovers. In comparison, a semi-soft handover algorithm for multi-bearer systems based on the *Site Selection Diversity Transmission* (SSDT) is proposed by the authors of [18]. MEN-NEMO is an LTE femtocell-based network mobility scheme that supports smooth handover for high-speed rail systems by utilizing multiple egress network interfaces [19]. Algorithms that modify the handover parameters based on the received signal strength have been proposed quite frequently. The TTT window proposed by the authors of [20] depends on Received Signal Strength (RSS). [21] proposes a unique handover technique, called-*LTE Hard Handover Algorithm with Average Received Signal Reference Power Constraint* (LHHAARC). LHHAARC focuses on reducing the number of handovers and handover delay, additionally increasing the overall throughput. LHHAARC puts certain constraints on average RSRP to enhance hard handover performance.

However, a solution that can effectively combat all the challenges of high-speed mobility scenario is still not available. Ping-pong handovers and *Radio Link Failure* (RLF)

remains persistent in high-speed environments, reducing the overall radio link quality. This paper attempts to solve these problems by proposing an effective handover technique.

1.3 Thesis Outline

This whole dissertation report is structured as follows:

- **Chapter 1: Introduction**

This chapter discusses the inspiration behind this study and explains the problem and the objective of the study.

- **Chapter 2: Synopsis of LTE Technology and Network Architecture**

Overview of the main features of LTE-Advanced Pro and discusses the network architecture.

- **Chapter 3: Mobility Management (MM) in LTE**

This chapter discusses the LTE procedures in use to support users in mobility mode.

- **Chapter 4: Challenges Encountered in High-Speed Environment**

In this chapter, the problems faced in the handover procedure for the high-speed vehicles are introduced.

- **Chapter 5: Proposed Handover Scheme**

The whole technique of the proposed handover scheme is discussed in details.

- **Chapter 6: Simulation for The Proposed Quick Handover Scheme**

Simulation and the results of our proposed handover scheme compared to existing techniques are shown.

- **Chapter 7: Conclusion**

This chapter is the summary of the key theories and findings introduced in this study, as well as the implications and what could be achieved in the future.

Chapter 2

Synopsis of LTE Technology and Network Architecture

2.1 Introduction

This chapter begins with an overview of LTE-Advanced Pro and key features, then delving into the network architecture.

2.2 LTE-Advanced Pro Overview

On the way to 5G-NR the last installment of 4G is LTE-Advanced Pro, often referred to as 4.5G, 4.5G Pro, 4.9G, Pre-5G or 5G Project. It is the terminology used to refer to 3GPP release 13 and 14. As it is the last version of LTE, it offers several advantages, some special features and overcome some limitations associated with the legacy versions of LTE. It also makes possible the efficient usage of IoT devices, vehicular communication and device to device communication.

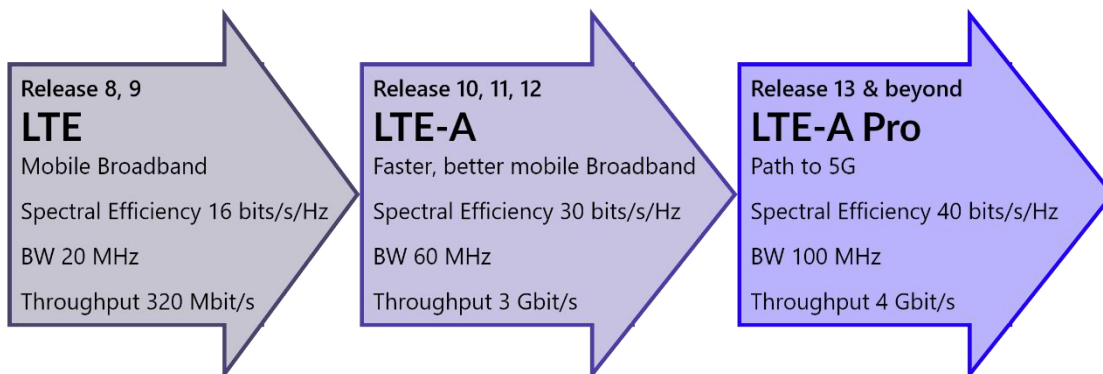

Figure 2.1: LTE Roadmap

Initial features of LTE-A pro:

Enhanced MIMO:

1. It allows the usage of elevation beamforming which enhances the horizontal beam steering. By doing this, up to 64 antenna ports can be supported.
2. By using 256 QAM, spectral efficiency can be improved and allows 8 bits/symbol

3. Extension of carrier aggregation allows massive aggregation in terms of licensed and unlicensed spectrum usage.

Connectivity Features:

1. It allows the combination of different data links from micro to macro cell or vice versa.
2. Direct device to device connectivity using a side link in the same network. For example: NB-IoT.

Several improvements can be seen in LTE-A pro like performance improvement in terms of user speeds and capacity over the previous generations and expansion of cellular technology in various fields and services.

Critical components of LTE-A pro:

1. Gigabit LTE: by using licensed and unlicensed spectral band it is possible to get up 2 Gbps to 4Gbps theoretically.
2. NB-IoT: It has ability not only to connect IoT devices but also it can provide extended coverage and varying data speed.
3. Private LTE: For large enterprise or specific users there can be a private high performance cellular technology which will be secure and private.

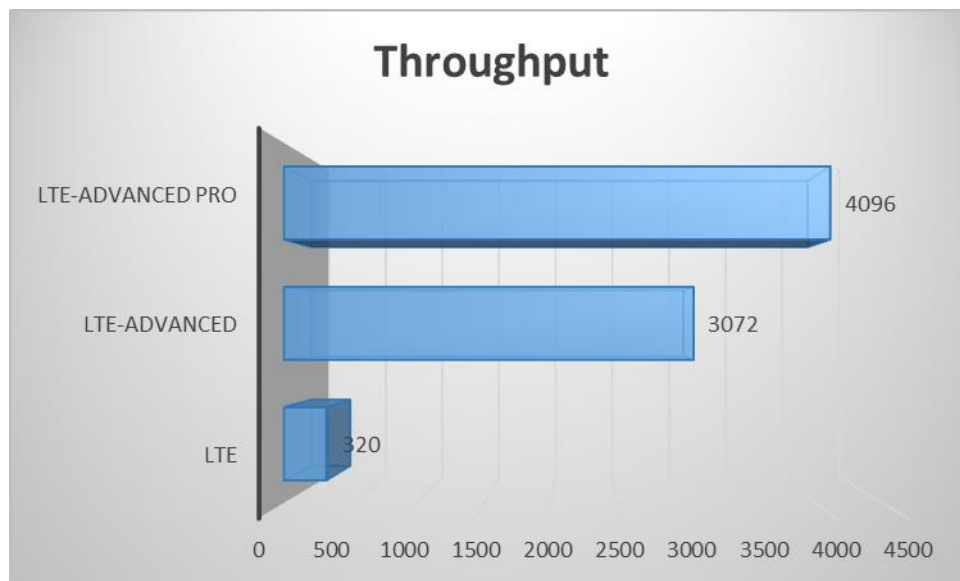

Figure 2.2: Throughput comparison among LTE, LTE-A and LTE-A Pro

4. Cellular vehicular communication: To connect a vehicle to other vehicles, infrastructure or everything else around the vehicle to improve control, enable better autonomous driving and improving safety.

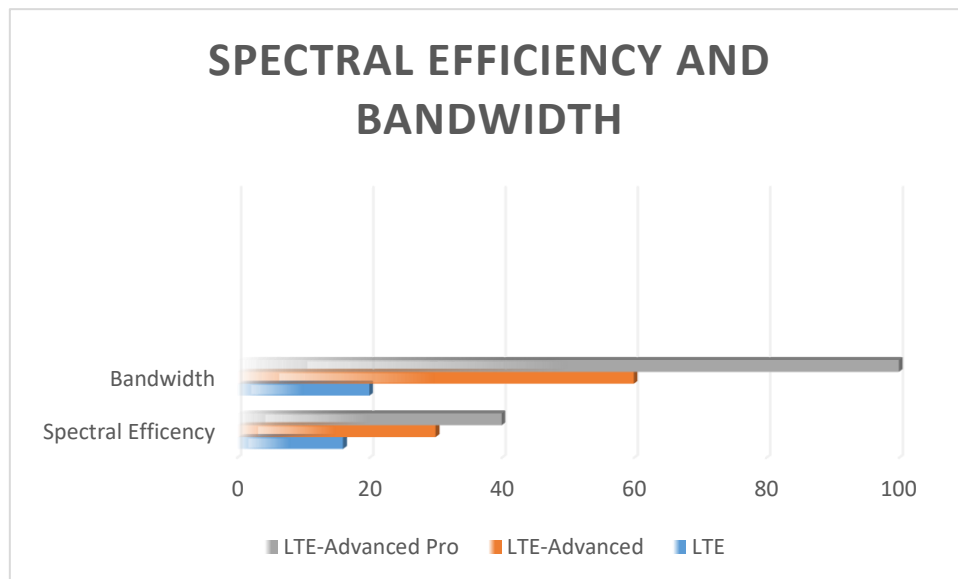

Figure 2.3: Comparison among LTE, LTE-A and LTE-A Pro in Terms of Bandwidth and Spectral Efficiency

LTE-A pro also overcomes the limitations in terms of bandwidth, spectral efficiency and throughput as it can be seen from the charts shown in Figures 2.2 and 2.3.

2.3 Network Architecture

The evolved form of 3GPP UMTS Radio Access, packet core is the Evolved Packet System (EPS), also commonly termed as LTE network, which is integrated to legacy 3GPP and non-3GPP networks. The network is comprised of two types of data flow path for maintaining Quality of Service (QoS) [1]. One of them is the User Plane and the other is the Control Plane. The purpose of separation of these two planes is to make the scaling of the network independent. Due to this, the operators can dimension and adapt their network easily. A simple network architecture for LTE is shown as an example in figure 2.4 which can be split into two major components: The Evolved UMTS Terrestrial Radio Access Network (E-UTRAN) and the Evolved Packet Core (EPC).

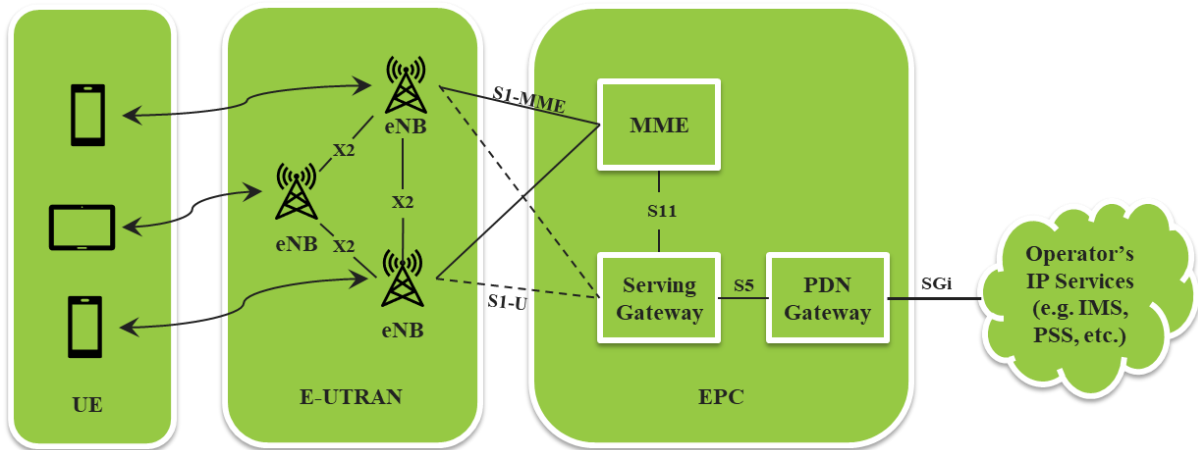

Figure 2.4: Simple LTE Network architecture

2.3.1 Evolved UMTS Terrestrial Radio Access Network (E-UTRAN)

This component of the LTE network architecture works like a new Radio Access Network (RAN), which basically consists only of the base stations - known as Evolved NodeBs (eNodeB) in LTE. As it only consists of eNodeBs, and has no radio network control entity, hence it is said to have flat architecture. The advantage of having flat architecture is that there is a significant improvement of latency due to fewer nodes in this part of the architecture. The eNodeBs are linked to one another through the X2 interface as shown in figure 2.4. The significance of establishing this interconnection through X2 interface is to allow the exchange of signaling information between the eNodeBs making it possible to carry on events like Handover or Cell Reselection procedures, radio resource allocation, etc. [22]. The eNodeBs act as bridges between the UEs and the Evolved Packet Core (EPC) where they're connected to the latter by the S1-U or S1-MME interfaces.

2.3.2 Evolved Packet Core (EPC)

The Evolved Packet Core (EPC) is the core network part of the non-radio aspects of the LTE network architecture, called System Architecture Evolution (SAE). The core network has some major components the most prominent of whom are shown in figure 2.4 which are: Mobility Management Entity (MME), Serving Gateway (S-GW) and Packet Data Network Gateway (P-GW). They are briefly overviewed as follows.

Mobility Management Entity (MME):

This is the main controlling entity of the core network. The MME deals with the control plane by handling the signaling related to mobility and security functions e.g., authentication and temporary identification of the UE for E-UTRAN access. This component is in charge of tracking and paging activities as well as regulating the signaling between the UE and its serving cell, required for successful exchange of data-packets.

Serving Gateway (S-GW):

The Serving gateway is concerned with the user plane. IP data traffic are forwarded and routed through the aid of this gateway between the UE and the external networks. The Serving Gateway informs the MME of incoming data whenever the UE is in idle state, which allows the MME to trigger paging of all eNodeBs of the tracking area. For each UE connected with the LTE network architecture, at a specific moment, it has a single S-GW assigned to it.

Packet Data Network Gateway (PDN-GW):

It also deals with the user plane and is the gateway to interface the network towards the Packet Data Network (PDN) and thus connectivity is established for the IP backbone. That is, this gateway acts as the interconnecting point between the EPC and the external packet data networks (called PDN). It functions in allocating IP address for the UEs.

Chapter 3

Mobility Management (MM) in LTE

3.1 Introduction

One of the most significant characteristics of cellular communication systems is ‘mobility’. This chapter focuses on giving a synopsis of how the mobility of the users is managed in Long Term Evolution (LTE).

The task of mobility management process is to keep the UEs connected to the network while they are in mobility mode i.e., while they move out of the coverage of one cell and enter into another cell. MME is assigned to control and manage this process by tracking and paging the UEs.

3.2 Radio Resource Control (RRC) States

In LTE, the UE can be connected with its corresponding serving eNodeB in two possible states which are called Radio Resources Control (RRC) states [28],[29]. These two states are used to identify whether the UE is connected to its serving eNodeB or not. These states are:

1. *RRC_CONNECTED State*: The UE is said to be in the RRC_CONNECTED state if the RRC connection is established between the UE and the serving eNodeB. In this state particular data packets of the UE are exchanged with the serving eNodeB, i.e., uplink and downlink data transfer occur when the UE is in this specific state. The location of the UE is known in this state with cell-level accuracy as RRC connection is established here.

2. *RRC_IDLE State*: Conversely, when there is no RRC connection established between the UE and its serving eNodeB, the status of the UE is RRC_IDLE state. The UE transitions to this state when there’s a long pause in data transfer process, hence, no data packets are exchanged in this state. No information about the UE is stored if it is in this state.

Based on the RRC state of the UE, when it is in mobility mode, there are two sorts of mobility management procedures that are supported in LTE, where, the decision to undertake these procedures also depend on the relative radio link quality for the serving cell and the

neighbor cells from the perspective of the UE. These procedures are known as Handover procedure and Cell Reselection procedure if the UE is in RRC_CONNECTED state or in RRC_IDLE state respectively. A brief overview of these two procedures is given in the rest of this chapter.

3.3 Cell Reselection

If the UE changes the cell on which it is camped in RRC_IDLE state, the cell reselection procedure takes place so that the UE may have the best radio link quality to its serving cell. This procedure takes place when certain cell reselection conditions are fulfilled, such as, finding a neighbor cell which gives better radio link quality to the UE compared to the serving cell for a minimum time interval. The UE is the decision maker of triggering the cell reselection procedure as there is no data packet exchange taking place in RRC_IDLE state, which means that the UE is not needed to be allocated radio resources by the network. The UE periodically searches for better suitable neighbor cells to connect to. Whenever a neighbor cell seems to fulfill the criteria for cell reselection of the UE for a specific period of time, the UE triggers cell reselection then. The UE compares the measurement result of serving cell and a possible destination cell frequently through

$$R_S = Q_{meas_S} + Q_{hyst} \text{ and } R_T = Q_{meas_T} - Q_{offset} \quad (3.1)$$

where, Q_{meas_S} and Q_{meas_T} are the Reference Signal Received Powers (RSRP) of the serving cell and the target cell respectively measured in dBm. The Q_{hyst} and Q_{offset} parameters are hysteresis margin and cell specific offset respectively, which act as biasing parameters, set by the eNodeB, for the cell switching decision making of the UE. If the target cell is found to give better signal for a particular duration $T_{reselection_RAT}$, then the UE decides to switch to the target cell. Whenever UE finds that $R_T > R_S$, the $T_{reselection_RAT}$ timer is triggered to start. If the condition is fulfilled even after the timer expires, the cell reselection procedure takes place.

The 3GPP has established a scale for cell switching variables for the convenience of the speedy users. Depending on whether a UE is in high mobility mode or in medium or normal mobility mode, the UE itself scales the Q_{hyst} and $T_{reselection_RAT}$ parameters so that it can be suitably be in the RRC_IDLE state with best radio link quality with the network. Otherwise, while passing through many cells in short period of time in high mobility mode, signal quality will drop drastically if those parameters are not tweaked accordingly, i.e., if cell reselection isn't done as soon as the signal from the new cell starts to get better than the camped or old

cell. Thus, for medium speedy or high speedy users, reducing the values of the Q_{hyst} and $T_{reselection_RAT}$ parameters accordingly are enough to ensure that the network performance is not degraded for the UEs. This is why this dissertation doesn't focus on cell reselection for UEs in high-speed metro rails and highways as the existing mobility support for cell reselection is sufficient for these cases.

3.4 Handover

If the serving cell of the UE changes when it is in RRC_CONNECTED state or when it is deemed a necessity to move a UE from a heavy data traffic cell to a light data traffic cell to balance the data traffic, then the handover procedure takes place [1]. Our thesis focuses on the first issue of when a UE changes its serving cell.

From section 3.2, it can be understood that by being in RRC_CONNECTED state, the user is connected to the network. To retain a user connected to the network even though they may travel from one network access point to another is the sole purpose of the Handover technique deployed in LTE mobility management process. In other words, when a UE travels from (say) a cell called cell-1 to cell-2, then the signal strength from cell-1 degrades gradually and the signal strength of cell-2 increases subsequently, this feature is utilized to ensure that ongoing calls or data connectivity for a UE goes on without being interrupted. So, the sole objective of the handover process is to ensure Quality of Service (QoS) all the time even while the UE is in the process of being handed over to a target cell, all the while utilizing the network in the most optimum possible way, without draining the UE battery. The principal parameter used to make the handover decision is measurement of signal strength between the User Equipment (UE) and the eNodeB.

3.4.1 Measurement Reporting

The UE transmits measurement reports to the eNodeB frequently, depending on whether it is event triggered measurement reporting or periodic measurement reporting. The measurement report contains the signal strengths of the serving cell and the neighbor cells. When the serving eNodeB receives a certain amount of measurement reports showing that a neighbor cell is providing a stronger signal than the serving cell by a sufficient amount, it transmits the handover command to the UE (backward handover). Otherwise, no handover command is given. As mentioned before, the measurement reporting may be of two types:

- **Periodic:**

There is no triggering prerequisite for sending the measurement reports. The UE sends measurement reports one after another regardless of satisfaction of any conditions until a certain maximum amount of measurement reports are transmitted.

- **Event-Triggered:**

The UE is triggered to send measurement reports when any of the five events A1, A2, A3, A4 and A5 takes place. As long as the event condition is met, the UE keeps on sending measurement reports one by one with certain intervals until a maximum number of measurement reporting is done. These five triggering events are as follows:

- **Event A1:** The UE enters this event when the serving cell becomes better than a threshold. The entering and leaving conditions for this particular triggering event are respectively:

Serving cell measurement – Hysteresis > Threshold and

Serving cell measurement + Hysteresis < Threshold

- **Event A2:** The UE enters this event when the serving cell becomes worse than a threshold. The entering and leaving conditions for this particular triggering event are respectively:

Serving cell measurement + Hysteresis < Threshold and

Serving cell measurement – Hysteresis > Threshold

- **Event A3:** The UE enters this event when the neighbor cell becomes better than the serving cell by an offset. The entering and leaving conditions for this particular triggering event are respectively:

Neighbor cell measurement + OffsetFrequency for neighbor cell + CellIndividualOffset for neighbor cell – Hysteresis > Serving cell measurement + OffsetFrequency for serving cell + CellIndividualOffset for serving cell + A3-Offset
and

$Neighbor\ cell\ measurement + OffsetFrequency\ for\ neighbor\ cell + CellIndividualOffset\ for\ neighbor\ cell + Hysteresis < Serving\ cell\ measurement + OffsetFrequency\ for\ serving\ cell + CellIndividualOffset\ for\ serving\ cell + A3-Offset$

- Event A4: The UE enters this event when the neighbor cell becomes better than a threshold. The entering and leaving conditions for this particular triggering event are respectively:

$Neighbor\ cell\ measurement + OffsetFrequency\ for\ neighbor\ cell + CellIndividualOffset\ for\ neighbor\ cell - Hysteresis > Threshold$ and
 $Neighbor\ cell\ measurement + OffsetFrequency\ for\ neighbor\ cell + CellIndividualOffset\ for\ neighbor\ cell + Hysteresis < Threshold$

- Event A5: The UE enters this event when the serving cell becomes worse than a threshold called Threshold-1 and the neighbor cell becomes better than another threshold called Threshold-2. The entering and leaving conditions for this particular triggering event are respectively:

$Serving\ cell\ measurement + Hysteresis < Threshold-1$ & $Neighbor\ cell\ measurement + OffsetFrequency\ for\ neighbor\ cell + CellIndividualOffset\ for\ neighbor\ cell - Hysteresis > Threshold-2$ and
 $Serving\ cell\ measurement - Hysteresis > Threshold-1$ or $Neighbor\ cell\ measurement + OffsetFrequency\ for\ neighbor\ cell + CellIndividualOffset\ for\ neighbor\ cell + Hysteresis < Threshold-2$

□ Common Parameters for Both Event-Triggered and Periodic Measurement Reporting:

For both Event-Triggered and Periodic Measurement Reporting, there are some parameters applied for both reporting cases. These parameters are included in the ReportConfigEUTRA (IE) as fields which is sent in the RRCConnectionReconfiguration message from the eNodeB to the UE [1]. They are briefly described as follows:

- *TriggerType*: Whether the measurement reporting is event-triggered or periodic is indicated by this field.
- *TriggerQuantity*: Whether the UE should send the measurement reports in terms of RSRP or RSRQ is indicated by this field.

- *ReportQuantity*: This field has only the binary values- “SameAsTriggerQuantity” or “Both”. As the first value name implies, if this value is chosen, the field then depends on whether the TriggerQuantity has been set as RSRP or RSRQ measurement reporting. If the value is set to “Both”, then measurement reporting will be done in terms of both RSRP and RSRQ.
- *ReportAmount*: The eNodeB specifies in this field maximum how many measurement reports are to be sent by the UE. The value of this field can be 1, 2, 3, 8, 16, 32, 64, or infinite. When the value of ReportAmount is set to infinite, the UE keeps on sending measurement reports until any of the reporting conditions changes.
- *ReportInterval*: This field specifies the length of interval between measurement reports. If the value is set to very low, the UE will have to send measurement reports very often which may drain the UE battery. This is why this field can have any of the fixed values 120, 240, 480, 640, 1024, 2048, 5120, or 10240 milliseconds or 1, 6, 12, 30, or 60 minutes.
- *MaxReportCells*: The maximum number of neighbor cells that are considered in the measurement report transmitted by the UE is set in this field, which can be at max 8.

The reason why these parameters were introduced in this section is due to the fact that some of these will be used with modifications in our proposed handover scheme.

3.4.2 *Handover Parameters*

Similar to the cell reselection process, in the handover process there are parameters to control the event triggered measurement reporting based handover procedure e.g., Handover hysteresis, TimeToTrigger (TTT), etc.

- **Handover Hysteresis**: Handover hysteresis is used to bias the network connection with the serving cell until a sufficient stronger signal strength from a neighbor target cell is obtained. The value of hysteresis is specified by the UE, which is used to determine the entering leaving condition for a particular event-triggered measurement reporting.

- **The TimeToTrigger (TTT):** This is another important parameter which is a timer used for avoiding ping-pong effects. Ping-pong effect takes place when a UE shifts between a serving cell and a neighbor cell repeatedly after a short duration due to it detecting one of the two cells having greater signal strength at an instant. The TTT parameter in handover process works like the $T_{reselection_RAT}$ parameter of cell reselection process where the UE waits for the entering conditions to be met for that time period. But unlike cell reselection, when the timer expires and the entering condition is met for that period, the UE doesn't change cells, it rather begins sending measurement reports to the serving eNodeB at a certain interval to a maximum limit.

3.4.3 Classification of Handover Procedure

The Handover procedure in LTE may be classified on the basis of different factors. For example, it can be classified on the basis of how the UE is handed over to the new cell [21], it can be classified on the basis of which entity makes the decision for the handover of the UE [30], it can be classified on the basis of through which interface the handover takes place (e.g., X2 based HO, S1 based HO), it can also be classified on the basis of which Radio Access Technology (RAT) the UE is handed over to (e.g., Intra E-UTRAN HO, Inter E-UTRAN HO, Inter-RAT HO), etc.

Based on how the UE is handed over to the new cell, there are two types of handover procedures:

- **Hard Handover:**

Often referred to as “*break-before-make*” handover procedure. It means that there is a brief delay of service while this handover occurs. The UE information for both control plane and user plane are transmitted from the source eNodeB to the target eNodeB in this handover. Usually, handovers in LTE have hard handover procedure incorporated in them.

- **Soft Handover:**

Often referred to as “*make-before-break*”. There is no delay of service while the handover takes place. The UE attempts to connect to the new eNodeB while parallelly being connected to the source eNodeB. A UE can sustain simultaneous connections with four or more cells. The most advantageous situation for this handover is that being connected to multiple cells simultaneously, the call or data connection could only fail if all signal qualities of all cells degrade at the same time.

Based on which entity makes the decision for the handover of the UE [30], there are two types of handover procedures:

- **Backward Handover:**

In this case, the network is the decision maker for the handover of the UE. This is why backward handover is basically described as a network-controlled mobility. It is the default handover mechanism used for LTE mobility management when signal quality degrades gracefully. Based on the certain maximum number of measurement reports received by the serving cell indicating that a neighbor cell is providing stronger signal compared to the serving cell by a suitable limit, the network gives the handover instruction to the UE. The handover related information is exchanged between the UE and the source eNodeB using the old radio path which is why it is called ‘backward’ handover. The prerequisite for this handover is that the radio conditions need to be good enough for both the source eNodeB and the UE to be successfully able to decode the measurement report from the UE & eventually prepare the target cell for handover and decode the Handover Command given by the eNodeB for the UE, respectively. Though the handover procedure incorporates hard handover in it, data forwarding and in-order delivery ensures that none of the data buffered in the source eNodeB is lost.

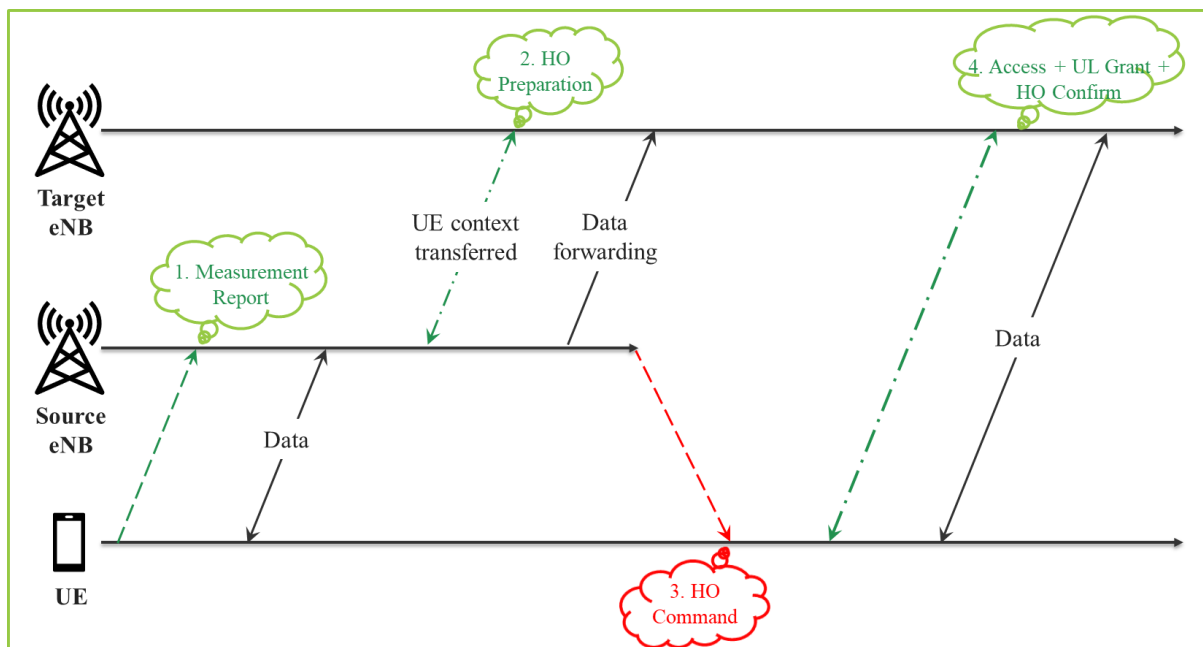

Figure 3.1: Basic LTE Backward Handover Procedure

- **Forward Handover:**

In this case, the UE itself is the decision maker for the handover of it. This is why forward handover is basically described as a UE-based mobility. The handover related information is exchanged between the UE and the target eNodeB using a new radio path after the UE context is fetched by the target eNodeB from the source eNodeB, which is why it is called ‘forward’ handover. In this handover procedure, even if the radio conditions are of poor quality, the handover can be done successfully. This robust feature of forward handover makes it convenient for rapidly changing signal strength conditions. There is still an additional delay resulted due to this handover in comparison to backward handover procedure. However, combining this handover procedure with PN code sequence detection as described in the proposed scheme in chapter 5, it will make it very convenient to be used for high mobility state users.

Chapter 4

Challenges Encountered in High-Speed Environment

4.1 Introduction

The 3GPP standards deployed are mostly the 4G (LTE, LTE-A, LTE-A Pro) standards globally. Though some regions have already started deploying 5G standard technologies since 2019 [27], 5G is still impractical for many scenarios e.g., rural areas, highways, railways, etc. The global data traffic is huge at present, even when it's compared to that from a few years past. This case is more evident to people as of the present times. The global pandemic that started spreading since December 2019 has impacted the world so profoundly that it compelled to transform business organizations, offices & institutions which required physical attendance of their personnel to virtual attendance. These virtual meetings and works demand vaster and faster data traffic. This huge data traffic is to be maintained and satisfied in accordance by the deployed standards of 3GPP. While the network service can be ensured satisfactorily to the stationary or 'slow speedy' or 'medium speedy' users, for the UEs in high mobility states, there is still an issue of degradation of network service with the current infrastructure. This chapter concentrates on the challenges in providing network service successfully to the high-speedy UEs.

4.2 Adjustment for Speedy UEs

The mobility state of a UE can be classified into three categories as follows:

- High-Mobility State: The UE enters this state when it is found that the UE goes through more than N_{CR_H} number of handovers within a maximum defined time duration.
- Medium-Mobility State: The UE enters this state when it is found that the UE goes through more than or equal to N_{CR_M} number of handovers and less than N_{CR_H} number of handovers within a maximum defined time duration.

- *Normal-Mobility State:* The UE stays in this state if neither medium nor high mobility states are detected during the maximum defined time duration.

4.2.1 Adjustment for Normal or Medium Mobility State UEs

For regular pedestrian or slowly or moderately moving UE vehicular cases, the handover margin is given for every base station, which is smartly sufficient for these cases. Using the parameters for handover as mentioned in section 3.4.2 which are hysteresis – that the network maintains itself, TimeToTrigger (TTT), etc. is convenient then. In these cases, the UE sends handover measurement reports for all neighboring cells to the source eNodeB. If it is found that a target cell is better than the serving cell by a suitable margin after obtaining some measurement reports for a maximum defined time duration, then the network gives the handover command to the UE.

4.2.2 Adjustment High-Mobility State UEs

When the user is in a high-mobility state, the parameters hysteresis, TTT, etc. and the protocols followed for a normal or medium mobility state UE are not enough for the network to cope with the device, majorly due to these protocols themselves causing a delay in the overall handover procedure. Typically, a specific TTT period is set by the network in case of event-triggered measurement reporting, after which the UE begins sending measurement reports maintaining a certain interval until a particular maximum number of reports is sent. For intra-frequency handover, events labeled as A1 to A5 are the five types of triggering events (section 3.4.1) - any of which is triggered whenever its condition is met and the TTT period initiates.

However, in most cases, the highly mobile users pass through the cell boundary long before the TTT ends. This overall delay in handover can cause Radio Link Failures (RLF) and possibly ping-pong events to take place as the signal strength between the source eNB and the UE can fall within this period. This ultimately leads to a handover failure. In this case, the UEs may be subject to very poor cell edge SINR due to a phenomenon termed as a dragging effect due to low signal strength from the serving cell and substantial interference from the target cell [29].

There is already a solution available for high speed users in 3GPP. The TTT can be scaled in case of handover when the user is in a high-speed state. In that case, the network

keeps track of how many handovers occur over a certain period. If it is found that many handovers occur within that period, it acknowledges that the user's speed is high. Thus, the network scales the TTT accordingly. However, this scaling is not robust enough. If the TTT is shortened too much for the high speed users, then within that short period, it might occur that a neighbor cell gives ample radio signal, thereby triggering the handover procedure without waiting for much time period. Immediately after that, the signal power of the former source eNodeB within that small scaled TTT might seem sufficient for it to become a source eNodeB again. Thus, a ping-pong event can result. So, to avoid ping-pong events, TTT is not shortened too much in LTE. However, this less shortening of TTT results in the high-mobility state UE passing through the cell boundary long before the handover is triggered. In that case, the worst-case scenario could be that the UE would get disconnected entirely from the source eNodeB before any triggering of handover to a new cell could occur, causing RLF. It might not be able to recover from RLF then. Thus, data loss would result.

4.3 Alternative Scheme

For this, an alternative scheme is proposed in this dissertation. The scheme proposes to modify the network to support the adaptive network functionalities required for high-speed users. The concerning parameters that the proposed scheme can maintain are:

- i) Seamless break during handover;
- ii) *Signal-to-Interference plus Noise Ratio* (SINR);
- iii) Minimal packet drops.

The primary concern for this dissertation is not only to handle RLF for users in high-speed vehicles but also to avoid any ping-pong events. For handling any ping-pong events, forward handover (see section 5.2.2) can be vitally significant for which this method is adopted in our proposition.

Chapter 5

Proposed Handover Scheme

5.1 Introduction

As days go by cellular communication faces new problems to solve. One of the main problems of this type of communication system is handover process for users in high speed vehicles. This handover is a sophisticated process where UE is in RRC_CONNECTED state and data continuously is exchanged. A simple problem in this process can cause RLF which leads to complete signal loss. Many handover schemes have been proposed to solve this high mobility scenario like enhanced cell margin, adaptive hysteresis, etc. But in our proposed scheme this problem is solved very efficiently and with very high accuracy. In this handover scheme, forward handover process and PN code sequence detection has been used to ensure a seamless handover procedure.

5.2 Prerequisite Techniques

5.2.1 Contention Based Random Access Procedure

Random access procedure is mainly of 2 types, one is contention based and another is non-contention based. In this type of random access procedure, a fixed amount of preamble is allocated per eNodeB. Also, some preambles are preserved for contention free access. Following steps are used in this type of random access procedure, which is also illustrated in figure 5.1:

1. Specific preamble is selected by UE and transmitted using available resources. Based on correlation eNB may detect that preamble.
2. After recognizing UE using that preamble eNB answers using that same preamble and allocate resource for that UE.
3. Then UE sends its identification and this depends on state (RRC_IDLE or RRC_CONNECTED)
4. Contention resolution is performed.

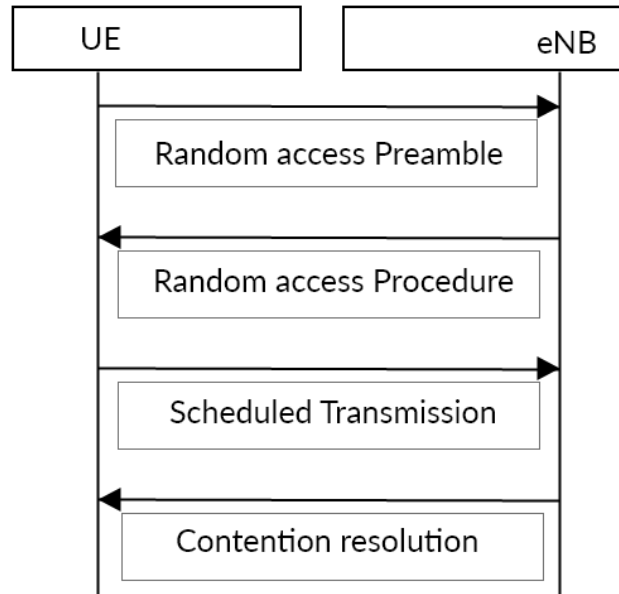

Figure 5.1: Contention Based Random Access Procedure Sequence

5.2.2 Forward Handover

Forward handover is described as a UE-based mobility, where the new radio path is utilized to exchange information between the UE and the source eNB. Forward Handover is successful even if the overall radio conditions are poor. As the UE is the decision-maker of the handover procedure in Forward Handover, it can be incorporated to facilitate quicker handover to take place. However, there is more complexity in this case, as the decision is not made by the same entity that maintains the co-ordination. The eNB has to prepare everything beforehand, and the data-path has to be switched accordingly after the handover is completed

In forward handover, multiple eNB has to be prepared to connect with UE. Also, UE will knock multiple eNBs to be connected with. As UE will make the handover decision and when this handover process will be triggered. So, the whole handover process will depend on UE. Non contention based handover cannot be used here. Because allocate each UE with a dedicated preamble (preamble is the specific number of bits which UE will use to knock the network) is not efficient and also it will not be convenient. So, contention based handover will be used here.

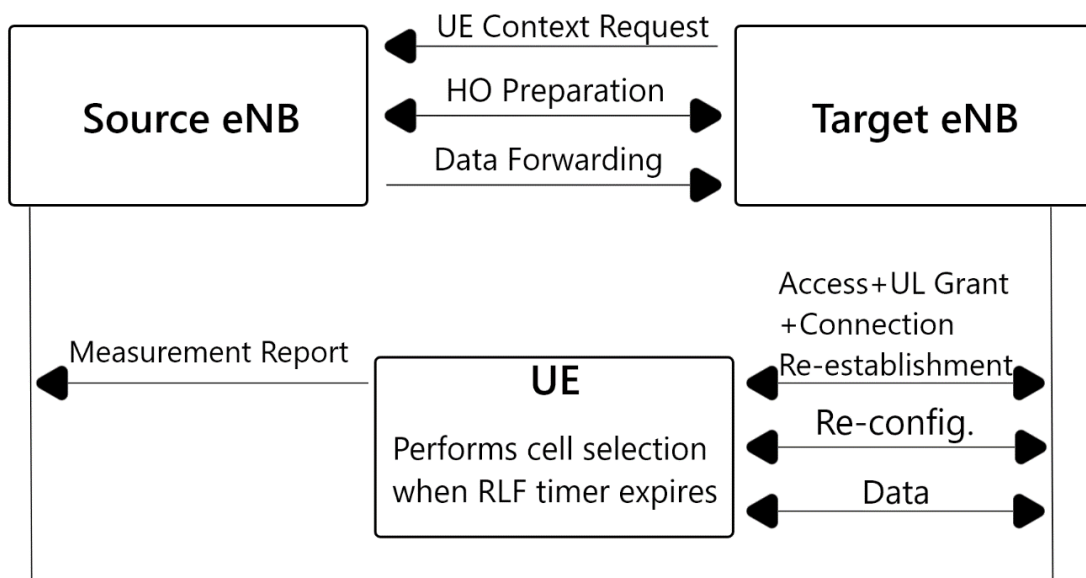

Figure 5.2: Forward Handover Procedure

5.2.3 Comparing Forward Handover with Backward Handover

Forward handover is described as a UE-based mobility, where the new radio path is utilized to exchange information between the UE and the source eNB. Forward Handover is successful even if the overall radio conditions are poor. As the UE is the decision-maker of the handover procedure in Forward Handover, it can be incorporated to facilitate quicker handover to take place. However, there is more complexity in this case, as the decision is not made by the same entity that maintains the co-ordination. The eNB has to prepare everything beforehand, and the data-path has to be switched.

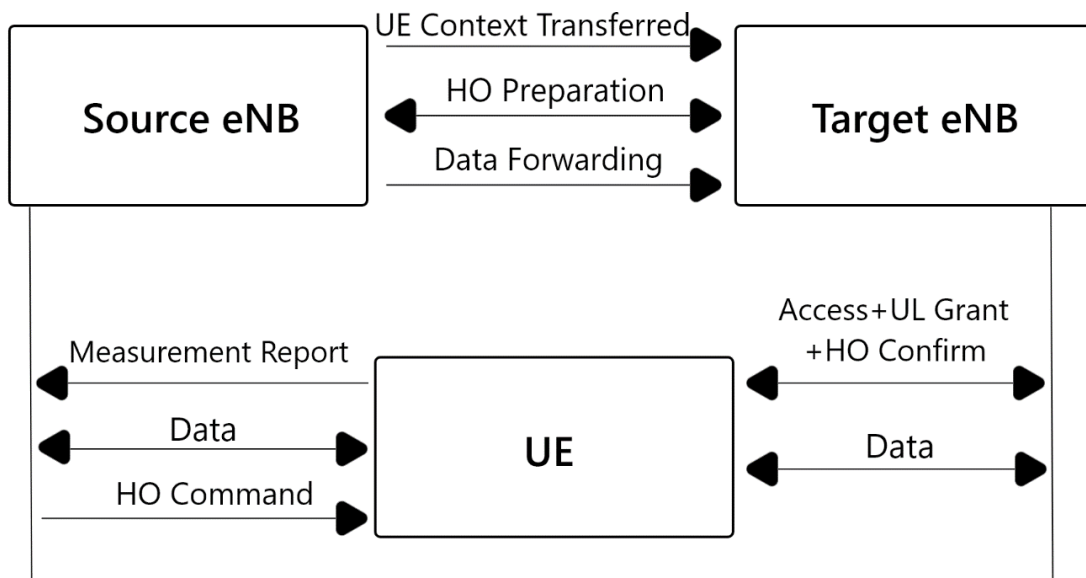

Figure 5.3: Backward Handover Procedure

Here, the network will decide when handover event needs to be triggered. Also, non-contention based handover can be used here as eNB knows about those UEs and can allocate dedicated preamble for each UE.

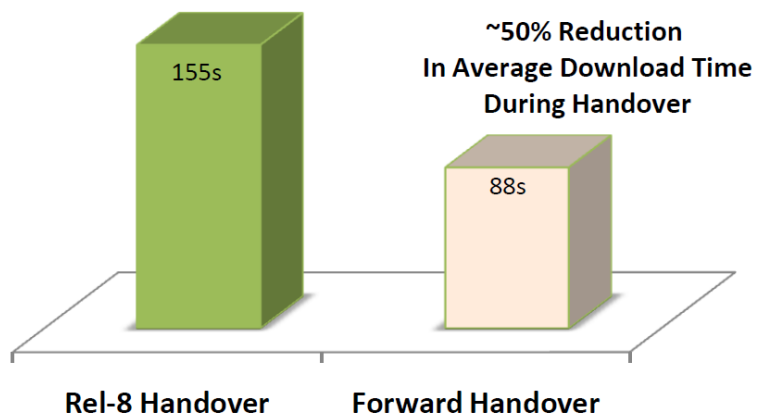

Figure 5.4: Time Requirement for each type of handover [30]

From this above comparison forward handover seems like a more suitable way to make faster handover process for UEs in high mobility state. That's why forward handover has been used in this scheme.

5.2.4 PN Code Sequence

It is also called as pseudorandom noise (PRN) or m-sequence. Using linear feedback shift resistor (LFSR) this type of sequence are generated. It is similar to a noise type of signal which consists of deterministic sequence and it repeats one by one after a specific time period. It has some specific properties:

1. It is a random bit sequence which repeats indefinitely
2. It has deterministic properties
3. Easy to generate with synchronization
4. High auto correlation and low cross correlation

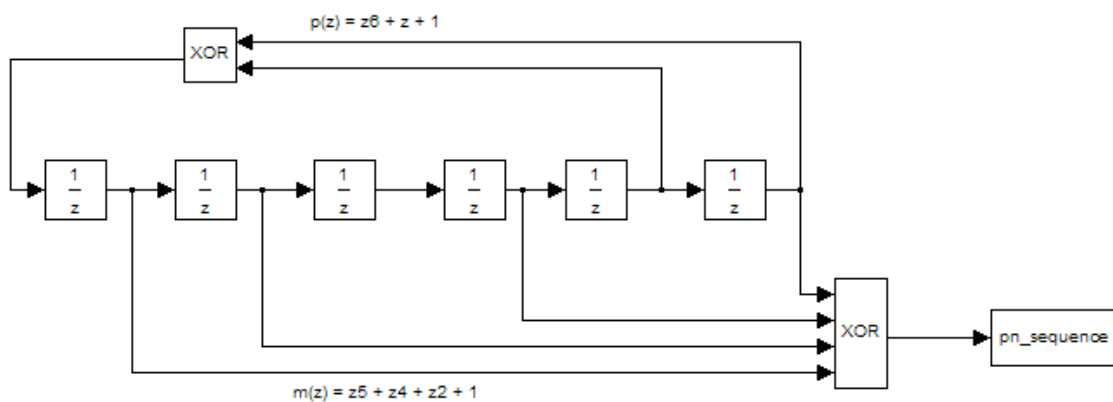

Figure 5.5: PN Sequence Generation

In direct sequence spread spectrum system, each bit of PN sequence is known as chip and inverse of its period known as chip rate. Some examples of this type of sequences are maximal length sequences, gold code, Kasami codes and Barker codes.

Short description about chip: in digital communication, chip is a pulse of direct sequence spread spectrum (DSSS) code such as PN code sequence. It is used in direct sequence code division multiple access (CDMA) channel access techniques.

It can be binary rectangular pulse of +1 and -1 amplitude, which is multiplied with data stream of +1 and -1 bits. Then using a carrier waveform, the whole sequence turns into transmitted signal. So, these chips are generated form a code generator.

On easy words it can be said that, chip rate of a code is number of pulses per second (chips per second) which is transmitted or received. For example, if bandwidth of a signal is 150 kHz, that means the signal wave has pulses of 150000 Hz per second or in other words 150000 chips per second.

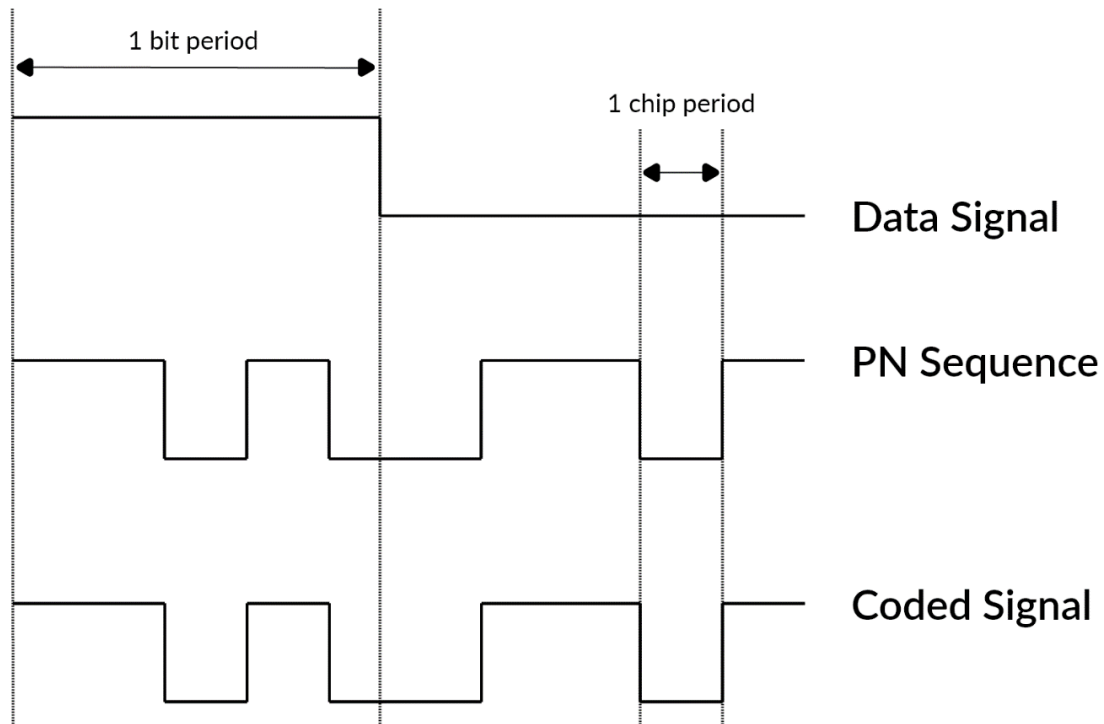

Figure 5.6: Combining data signal with PN sequence

Using PN code sequence detection along with forward handover, is proposed in this scheme due to its convenient correlation features. These features enable the PN sequence to be used distinguishably in DS-SS techniques. The auto-correlation of the sequence is also significant since it dictates the capability of synchronizing and locking the spreading code for the received signal.

PN sequence can be transmitted from multiple eNodeBs. Here, each eNodeBs nearby highways and high-speed metro-railways can be modified to broadcast two types of PN codes, which are described as follows:

Short Code:

It is $64 \times 8 = 512$ chips long code, where 64-bit sift is used. It is used to define the identity of an eNB, and the eNB broadcasts it. All the eNBs are synchronized, and they transmit the short code simultaneously. It can be repeated multiple times within a short period. To distinguish the eNBs, each base station is allocated a cyclically shifted variant of the same short code sequence. UE can recognize each eNB using this short code. Hence, if there is a 64-bit shift, then, by using 512 chips long code, 8 eNBs can be covered by it. For example,

0-64	64-128	128-192	192-256
eNB-1	eNB-2	eNB-3	eNB-4

Table 5-1 Example of short code for identifying eNB

Long Code:

A predefined symbol sequence which will be scrambled by a different long code. It might be $2^{15} = 32768$ chips long. Both the eNB and the UE will know this sequence at a particular time instant. So, this code is usually encrypted. UE will recognize handover triggering point by tracking this long code. The UE gets this information using RRCConnectionReconfiguration message. The RRCConnectionReconfiguration message will indicate the triggering positions preliminarily for code sequence for each cell (Cell-1, Cell-2, Cell-3, and so on) by a list.

This long code will be repeated as cycle by cycle. For example, one cycle consists with 32768 chips long. So, after 32768 chips new cycle will be started. This way this code transmission and reception will continue in a cyclic way.

0-32768	0-32768	0-32768
Cycle-1	Cycle-2	Cycle-3

Table 5-2 Example of long code repetition cycle by cycle

5.2.5 Additional Bandwidth

In LTE, a specific narrow frequency range is used to separate two useful frequency ranges, to avoid interfering with each other, which is called guard band. A diagram illustrating guard band in between frequency channels is shown in Figure 5.7.

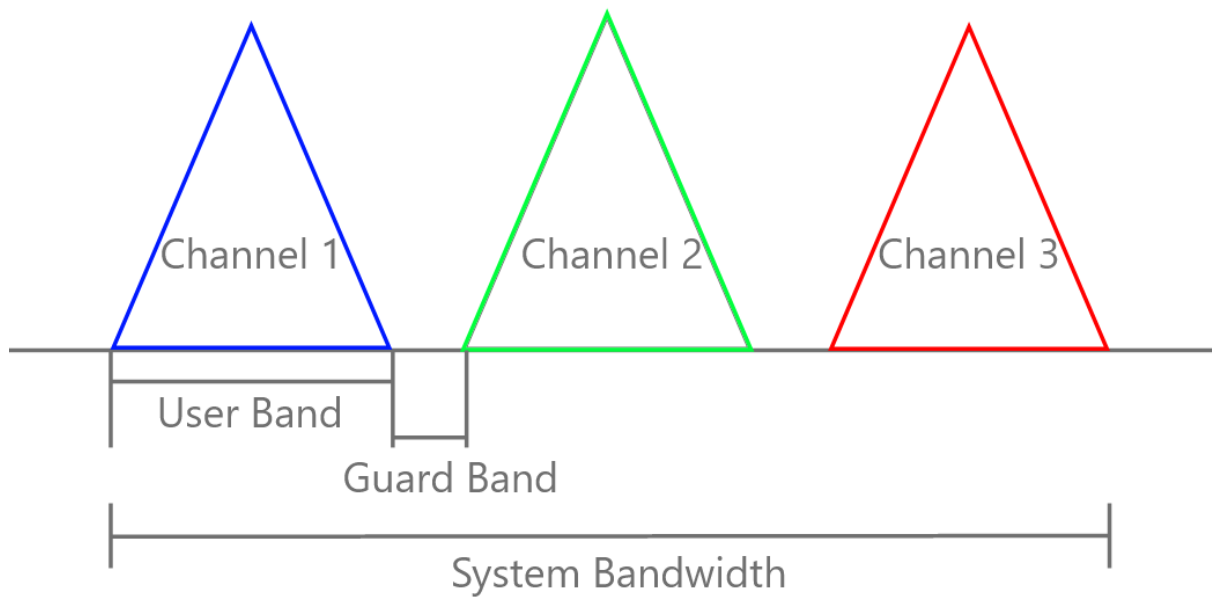

Figure 5.7: Guard Band

Guard band is defined to be 10% of the available bandwidth – where, it is distributed as having 5% in the upper limit and the rest 5% in the lower limit. E.g., if channel bandwidth is 10 MHz, then guard band width is 1 MHz, 500 kHz of which is in the upper range and the rest 500 kHz is in the lower range. Hence, allocating a small band within the LTE guard band will not result in compromising any part of the useful available band & it will be convenient for addressing the problem associated with a user in high mobility mode.

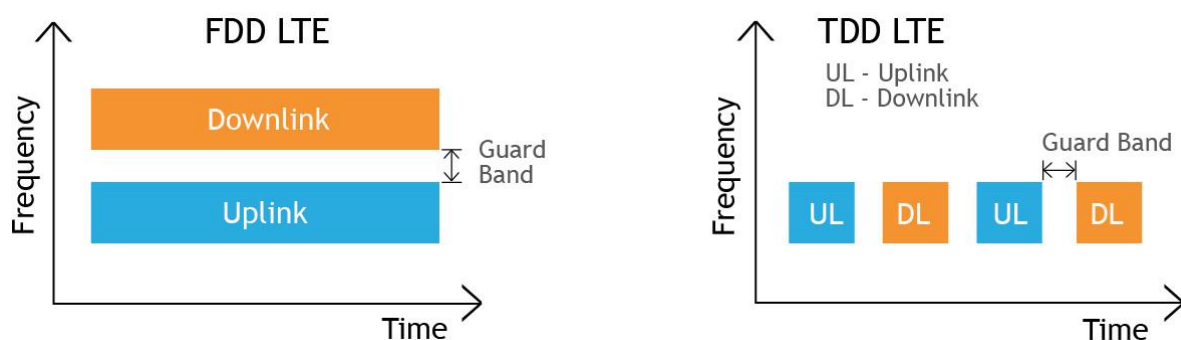

Figure 5.8: Guard Band in LTE

As allocating a small portion of bandwidth from this guard band won't cause any trouble in the main communication scheme, this small bandwidth has been used in this handover scheme to receive and transmit short code and long code. By doing this, there will be several advantages, like no additional bandwidth won't be required and typical communication scheme won't require further modification. For getting these advantages this proposed handover scheme will use small bandwidth from guard band of LTE.

5.3 Handover Scheme

The proposed scheme's handover procedure is as follows, the sequence of which is also illustrated in Figure 5.9.

- i.* A specific range of guard band of LTE needs to be used as an additional communication path. Small bandwidth will be allocated for the additional communication path within guard band of LTE. This specific bandwidth will be used to send or receive short code & long code. Upon receiving the short code, the UE will know the identities of the eNodeBs, and upon receiving the long code from the serving eNodeB, UE will maintain handover time synchronization.
- ii.* UE will make the handover decision at a particular time instant based on PN sequence (long code) transmission length as Forward Handover is used here. The decision-making process will not depend on any measurement report. But exchanging of measurement reports will be continued. As UE and serving eNodeB both will acknowledge the long code, at a specific length of transmission of long code, serving eNodeB and UE both will start taking preparation to make the handover.
- iii.* Serving eNodeB will let possible Target eNodeBs within its neighboring range know a particular preamble of a specific UE beforehand so that the negotiation between serving and target eNodeB for handover of that particular UE will happen before the UE disconnects from serving eNodeB and connects to the target eNodeB. This will be the first step to taken by serving eNodeB to prepare for handover.
- iv.* Contention based Random Access procedure will be followed here. So, UE will select the PRACH resource and using this resource UE will knock the possible target eNodeBs. By doing this UE will be able to communicate with multiple

possible target eNodeBs. This is vital in Forward Handover procedure. This will be the first step to taken by UE to prepare for handover.

- v. The possible target eNodeBs will be directed by the serving eNodeB to allocate resources and prepare to find and connect to the UE when the HANDOVER_REQUEST message is sent from UE to those eNodeBs. If target eNB can allocate resources and recognize that particular preamble sent by the UE (correlating it with the preamble sent to it by the serving eNB), then the target eNB will accept the request and send an acknowledgment message to the serving eNB. This will enable a quicker handover to take place. Here, the process of entering the new cell by the UE will result in a bit more delay than that of the Backward Handover procedure. Nevertheless, the higher delay that happens in Backward Handover procedure in sending the measurement reports, analyzing them, and waiting for setting up handover process & handover command from the serving cell is minimized - in such a way that, when it is holistically observed, the overall delay in the handover procedure is minimized significantly when Forward Handover is adopted.
- vi. For this case, multiple eNBs have to be prepared. The UE will listen to multiple eNBs too. Serving cell will send the RRCConnectionReconfiguration message to the UE which contains the short code, which identifies at least 3 possible target eNBs. Based on the location of the UE, its travelling direction, code length, and Random Access Response, UE can estimate how long it is listening to some specific eNB, how far the eNB is from the UE and how its signal strength is. Based on these parameters UE will select one eNB to be handed over to among those possible target eNBs send by serving eNB via RRCConnectionReconfiguration message. This concludes handover preparation, taken by both UE and the network.
- vii. As PN sequence (Long code) has a particular length for each cycle, and it continues to be transmitted cycle by cycle, the sequence length (combining all the cycles) needs to be monitored because a specific number of bits will be transmitted after a particular time. At that specific length and time handover needs to be triggered. UE will know this handover triggering time from RRCConnectionReconfiguration message. So, at that specific time handover will be triggered and handover execution will be completed. This process will also be time-synchronized as periodic handover event has been used here.

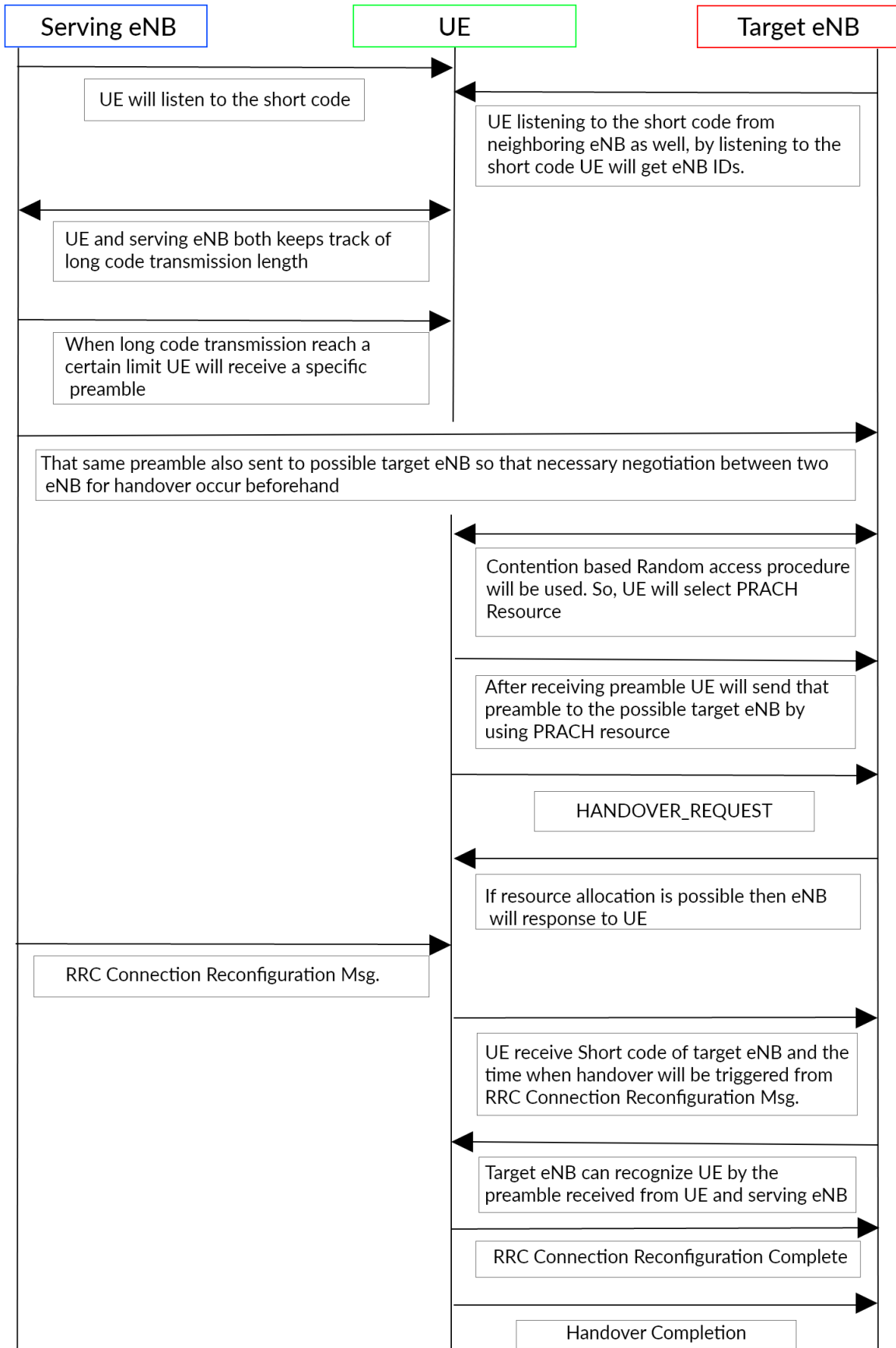

Figure 5.9: Proposed Handover Scheme

- viii. Target eNodeB will confirm successful handover for the UE, and the data path will be switched to the new data path. After confirming the successful completion of handover, UE and the new serving eNB (former target eNB) will continue tracking the PN sequence code length. The serving cell will allow a fixed amount of time for a particular UE. So, resource allocation will be fixed, and releasing resources will not be of a big concern.

The overall sequence of the handover procedure for the scheme is summarized in Figure 5.10. Also, the usual RRCConnectionReconfiguration message along with the modifications needed in its different fields (section 3.4.1) for the proposed scheme is shown in Table 5-3 below.

Usual RRC Connection Reconfiguration Message	Proposed RRC Connection Reconfiguration Message
<pre> rrcConnectionReconfiguration . . triggerType = event = eventId = eventA1 = 68 hysteresis = 6 triggerQuantity = rsrp . . . </pre>	<pre> rrcConnectionReconfiguration . . triggerType = periodic [next eNodeB id(short code)] hysteresis = NULL triggerQuantity = [time (according to eNodeB distance and code length)] . . </pre>

Table 5-3 Modifications Required in RRCConnectionReconfiguration Message

A comparison of time & some other procedural requirements between the usual handover procedure and proposed handover procedure is shown in table 5-4 below.

Process Name	Usual Handover in LTE	Proposed Handover
DL synchronization to the target eNB	Required	Required
RACH waiting time	Required	Required
Sending dedicated preamble to request UL resource	Required	Required
Detecting preamble from the target cell	Required	Not required
Preparing the RACH response message	Required	Not required
Decoding RACH response message	Required	Not required
Informing target cell	Required	Not required
Obtaining target cell configuration	Required	Not required

Table 5-4 Usual Handover Procedure vs. Proposed Handover Procedure

5.4 Taking Care of Some Critical Parameters

The way some critical parameters have been resolved in the proposed scheme are described as follows.

Direction of Vehicle: On a highway or a railway, a vehicle can ply towards both directions (forward/backward). For separating UEs according to their moving directions, we have to consider 2 sets of long codes. One for those vehicles moving forward while the other for those vehicles moving in the opposite direction. By using these 2 sets of codes, it will be easier to keep track of code length.

For example, we can use 2 set of code sequence like gold code for forward going UE and Barker code for backward going UE. By correlation this 2 sets of code can be separated and can be used accordingly.

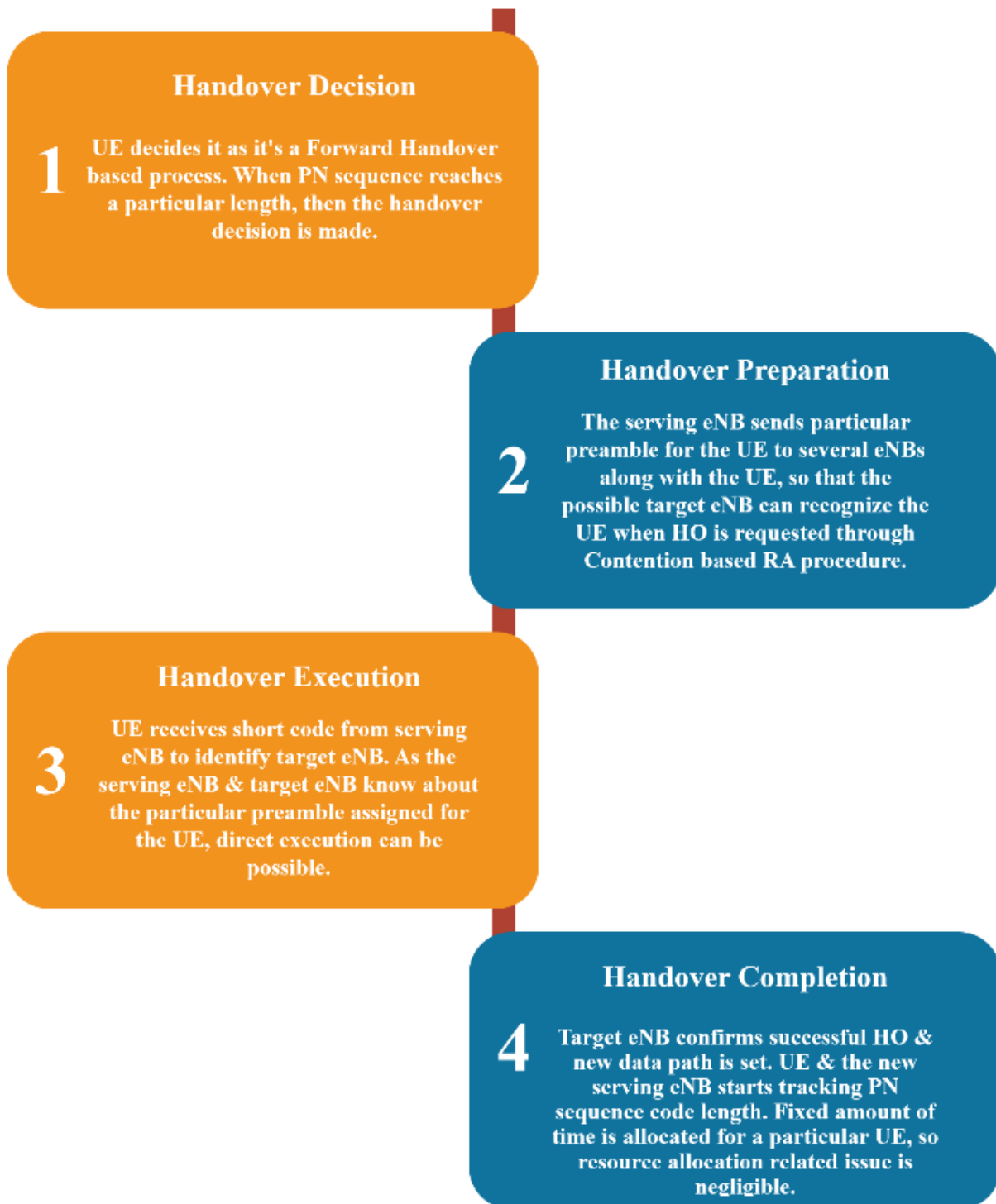

Figure 5.10: Sequence of Proposed Handover Scheme

Vehicle Speed: The speed of the vehicles may vary from time to time. Furthermore, listening to long code from one eNB will not be enough to detect handover triggering point accurately. So, in our proposed scheme, one UE will listen to 5 neighboring eNBs simultaneously; 2 of these eNBs are the ones that the UE was connected to formerly and the

remaining 3 are the neighboring eNBs that may be the next target eNB. The more eNBs the UE listens to, the more accurately it can pinpoint its handover triggering point.

We can see type of technique to increase accuracy in GPS. Like it listens to multiple satellite to pinpoint the location. GPS listens to at least 3 satellite to get a user position. E.g., to get longitude device will listen to one satellite and to get latitude device will listen to another satellite. After listening to at least 4 or more of the GPS satellites, it can pinpoint user location with higher accuracy.

Distinguishable eNodeB IDs: eNB IDs have to be unique and easily recognizable by UEs so that UEs can recognize the specific region where this scheme will be used. By establishing connection to these specific eNBs, UEs will also know that multiple handover events may occur and transmitting power will be lower. Furthermore, the UE will not detect these multiple handover events as ping-pong events, too.

If these eNBs not separated from the usual eNB then UE will face several problems like UE can get confused between this proposed handover scheme and usual handover scheme. Also, the short code with shifting to identify eNB can make troubles like covering a large area with large number of eNBs can make short code length higher which will require more bandwidth.

Normal Speedy UE within that Region: When a UE is within a suitable range of a specific eNB for a significant timespan, in that case, it can be said that either the UE transitioned to a stationary or a pedestrian mode/low speed vehicular mode. In these specific cases, when the UE receives the 2 types of codes broadcasted in their specified band (within LTE guard band), it will get confused. For this, the Serving eNB can detect those specific UEs by utilizing their long code listening time and their possible target eNB IDs (which will remain unchanged for that significant timespan). The Serving eNB then will bring those UEs back to usual LTE handover scheme, i.e., Backward Handover procedure.

Distance between each eNodeB: In this specific region, the distance between each eNB will be more or less same so that the handover triggering point can be determined easily. Also, it helps to make handover periodic. Also, by doing this serving cell will allow a fixed amount of time for a particular UE. So, resource allocation will be fixed, and releasing resources will not be of a big concern.

By having non uniform distance between each eNBs, it is impossible to make handover periodic also resource allocation and releasing resource for a particular UE will make this scheme more sophisticated.

5.5 Sample Calculation

The For broadcasting short and long codes, by allocating 150 kHz within the LTE guard bands, we can get around 150000 chips per second (cps) in downlink. So, receiving 32768 bits will require $\frac{32768}{150000} = 0.21$ seconds.

Suppose, length of long code is 32768 chips/cycle, vehicle speed is 350 km/hr. (97.2 m/s), distance between each eNB is 2 km (may not be uniform practically and has to be modified for each case accordingly). For passing that 2 km, the vehicle requires $\frac{2k}{97.2} = 20.57$ seconds. As each cycle requires 0.21 seconds, hence, within 20.57 seconds, $\frac{20.57}{0.21} = 97.95$ cycles can be transmitted. The serving eNB can send 97 cycles completely within the 20.57 seconds. So, these completed cycles will not be of any concern. However, for the remaining 0.95 cycle, $0.95 \times 32768 = 31129$ chips need to be transmitted and in this exact code length of this cycle, handover event needs to be triggered.

In the meantime, listening to other 5 neighboring eNBs (2 former serving eNBs & 3 possible target eNBs) is equally important. The reason behind this is that, in that exact time, 5 other code lengths will also come to some specific fractional points, at which handover event needs to be triggered for any one of them. This will improve the accuracy of handover event and time synchronization.

So, 6 different fractional points will come from 6 different cycles transmitted by 6 different eNBs & all will align at a point. The information about this alignment point will be sent by serving eNB to the UE via RRCConnectionReconfiguration message.

The serving eNB will include the identities of at least 2 next possible target eNBs in this RRCConnectionReconfiguration message. The UE will decide its target eNB according to location, code length and signal strength. If the UE is allowed 2 cycles to determine these parameters, then the TimeToTrigger will be $2 \times 0.21 = 0.42$ seconds. After this time, if the conditions are met, handover event will be triggered accordingly.

A proper handover step will be triggered by tracking the code lengths as illustrated in Figure 5.11. It will not depend on any measurement report; rather, it will be automatic as it is a time-synchronized process.

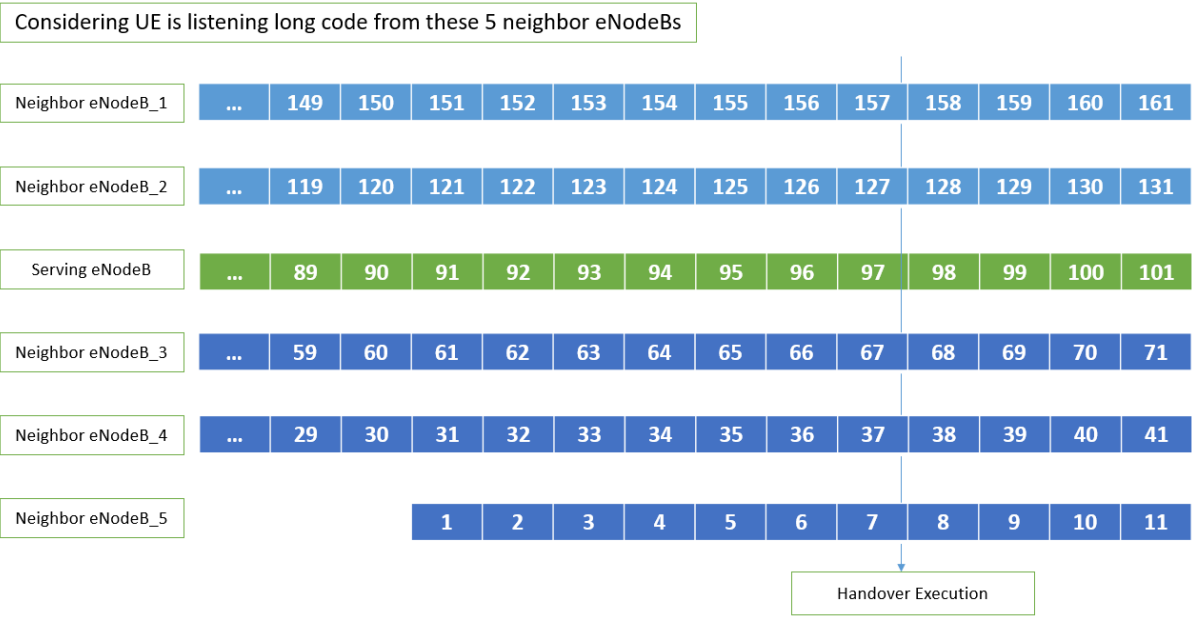

Figure 5.11: Operation sequence with respect to code length for the proposed HO Scheme.

Chapter 6

Simulation for The Proposed Quick Handover Scheme

6.1 Introduction

To exhibit that successful completion of seamless handover is possible using the quick handover procedure suggested by the proposed scheme, a MATLAB-based simulation has been performed.

6.2 Simulation Parameters

The simulation assumptions are shown in Table 6.1, the parameter values of which comply with the 3GPP specifications. Primarily, the simulation corroborates the performance due to the forward handover plus PN code sequence detection incorporated quick handover procedure (proposed scheme) and compares it with the existing scheme in the cellular network. Due to limitations in the simulation environment and its accessibility, an overarching corroboration of the proposal could not be achieved at the moment. With the availability of a strong system-level simulator, a proper simulation for the proposed scheme is achievable.

6.3 Simulation Scenario

In the simulation, the results have been obtained assuming that a user moves via a high-speed vehicle on a highway or a high-speed railway from one cell to another in a straight path connecting the eNodeBs of the two cells. For a usual existing scheme, suppose after a certain distance d from the serving eNodeB, it is found that the current cell may no longer be viable as certain conditions are met for triggering handover command. Then, assuming that the handover is triggered after n number of measurement reports at a reporting interval of $t_{interval}$, the actual handover is triggered at a distance,

$$d' = d + (v \times TTT_{usual}) + (n \times t_{interval} \times v) \quad (6.1)$$

where TTT_{usual} represents TimeToTrigger for the existing scheme.

Parameter	Value
Operating frequency (DL)	10 MHz
User velocity (constant), v	50, 100, ..., 350, 400 km/hr.
User direction	Moving from one eNB to another eNB
Path Loss model	Okumura-Hata
EIRP at eNB	40 dBm
The separation between 2 eNBs	2 km
Antenna height for eNB	30 m
Antenna height for UE	2 m
Reporting method for HO	Periodical
TimeToTrigger (existing), TTT_{usual}	2.64 sec
TimeToTrigger (proposed), $TTT_{Proposed}$	0.42 sec
P_{O_PUSCH}	-102 dB
α	0.8
No. of RBs, M_{pusch}	10
Δ_{TF}	0
F_{TPC}	0

Table 6-1 Assumed Parameters for Simulation

For the proposed scheme, $n=0$ in (6.1) as the UE's handover decision-making process does not depend on any measurement report so that the handover decision is made quicker. Thus (6.1) results in

$$d' = d + (v \times TTT_{proposed}) \quad (6.2)$$

The UE computes its transmit power as [1]

$$P_U = P_{O_PUSCH} + \alpha \times PL + 10 \log_{10} M_{PUSCH} + \Delta_{TF} + f_{TPC} \quad (6.3)$$

where P_{O_PUSCH} is an eNodeB configured basic parameter for power control used to achieve a suitable SINR at the eNodeB. The path loss associated with the radio link has been estimated using the Okumura-Hata model. The UE approximates the path loss associated with the downlink from cell-specific reference signals (RS) by measuring the linear average over the power contributions of the RS's resource elements within the considered measurement frequency bandwidth. The estimated path loss in downlink,

$$PL = ReferenceSignalPower - Filtered RSRP \quad (6.4)$$

To reduce the effect of PL , i.e., path loss, the parameter α is used. The eNB broadcasts α to the UE on SIB type 2. M_{PUSCH} represents the number of resource blocks (RBs) allocated on the subframe for which the uplink power is calculated. M_{PUSCH} allows the use of more power as a wider uplink bandwidth is utilized, and it attempts to keep transmit Power Spectral Density

(PSD) in an RB constant. The parameter Δ_{TF} or $\Delta_{Transport_Format}$ facilitates the higher transmission power required when UE uses a higher level of Modulation and Coding Scheme (MCS), and this compensation for MCS can optionally be deactivated, which sets $\Delta_{TF} = 0$. The term f_{TPC} is used for continuous closed-loop power adjustments, and the eNodeB sends transmit power control (TPC) command to set the value of f_{TPC} .

6.4 Simulation Results

Using the simulation assumptions of Table 6-1 in (6.3), the power required for transmission from UE is plotted against the distance of the UE from the serving eNodeB, which is shown in Figure 6.1. The figure compares the estimated transmit power behavior of UE in the existing scheme with that in the proposed scheme. The transmit power profile of UE for the existing scheme illustrates the scenario where the UE has passed through the cell boundary long before the handover could be triggered. The proposed scheme's transmit power profile illustrates how this problem for the existing scheme can be mitigated. through it as halfway through the distance between the serving eNB and the target eNB, handovers are triggered.

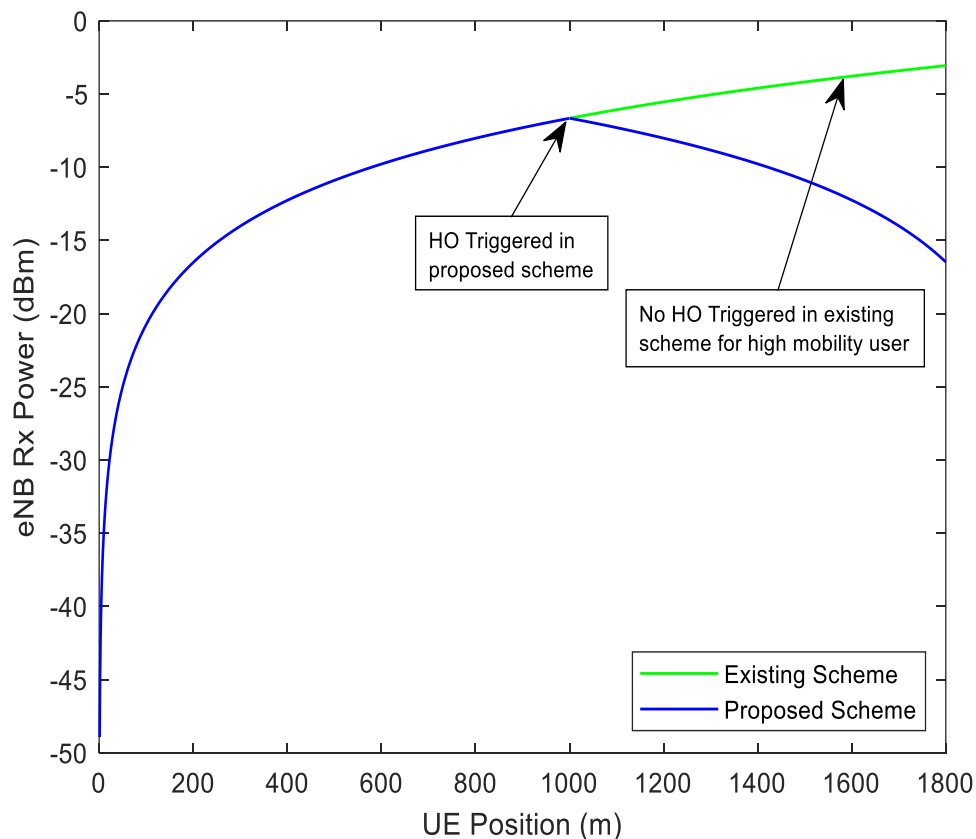

Figure 6.1: UE transmit power vs. distance from eNB of one cell as the UE moves to another cell.

Furthermore, a profile for some fixed user velocities against the received power from the source eNodeB at the handover triggering position, i.e., P_{R_Min} , has been obtained from the simulation result. Figure 6.2 illustrates the P_{R_Min} vs user velocity profile behavior for both the usual existing scheme and the proposed scheme. From Figure 6.2, we can see that when UE speed is higher, the signal quality is getting worse as we know that in the usual handover scheme, handover depends on measurement report, hysteresis, and higher *TimeToTrigger*. As handover trigger time is higher so in the existing scheme, the signal drop is higher before the handover is triggered. However, our proposed scheme does not depend on these parameters, and handover will be quicker, and signal drop will not be higher.

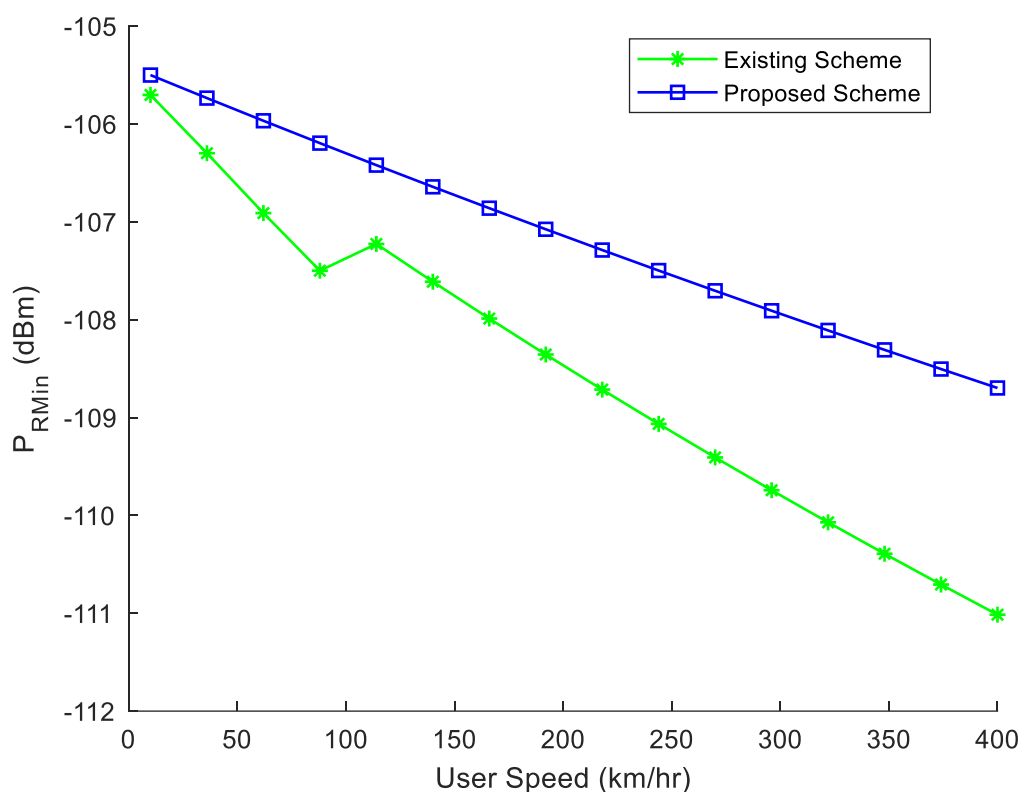

Figure 6.2: P_{R_Min} vs. user speed for handover

The handover delay vs. user speed for the handover profile is illustrated in Figure 6.3. For the existing scheme, while the user is in high mobility mode, the delay is calculated as the time that elapses between crossing the cell boundary and the handover triggering decision made after a certain number of measurement reports are received. On the other hand, for the proposed scheme, in high mobility mode, the delay is calculated from the moment the long code transmission reaches a specific length until the target eNodeB recognizes the UE from its transmitted Random Access preamble to the target eNodeB depending on the dedicated Random Access preamble allocation. The lowest value of the handover delay is 4.041 sec in

the simulation for the existing scheme, which occurs at a 400 km/hr. user velocity. At the same velocity, for the proposed scheme, the lowest value of the delay is 2.841 sec which is significantly lower than that for the existing scheme in LTE. In fact, for all the user speed cases, the delay profile in the figure illustrates that the proposed scheme gives less handover delay than the existing scheme all the time. This corroborates that the proposed scheme of incorporating a quick handover procedure, i.e., incorporating Forward Handover along with PN code sequence detection in LTE, substantially trumps the existing scheme in LTE for the better suitability of the users in high mobility mode.

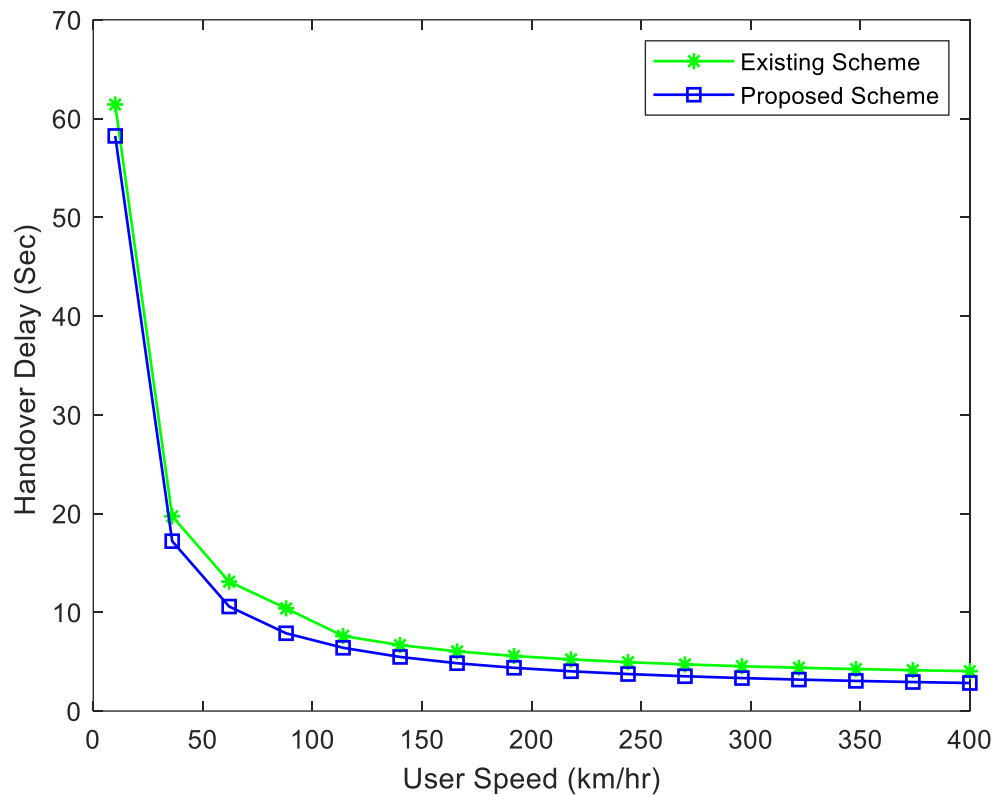

Figure 6.3: Handover delay vs. user speed for handover

Chapter 7

Conclusion

The technologies presently used in LTE are not completely capable of addressing issues such as radio link failure and ping pong effects for users in high-speed transportation. The proposed scheme in this paper described a quick and seamless handover procedure to combat these issues. This scheme incorporated forward handover so that the UE can initiate handover, making the whole procedure faster than the usually used backward handover procedure. This scheme used PN sequence detection which complements forward handover by determining the exact time at which handover procedure should be initiated, making it a time-synchronized process independent of measurements reports by the UE; thus, shortening the *TimeToTrigger* (TTT) considerably as well as significantly reducing unnecessary ping-pong handovers. The simulation results showed promising results supporting the potential merit of the proposed scheme. Nevertheless, there is still scope for improvement. Future works involving this proposal includes minimizing the handover delay even more, distinguishing normal speedy vehicle and high-speed vehicle more efficiently and determining the direction of the vehicle more precisely

References

- [1] Mohammad T. Kawser, "LTE Air Interface Protocols", Artech House, Boston, USA (2011). ISBN: 978-1-60807-201-9
- [2] M. Pan, T. Lin and W. Chen, "An Enhanced Handover Scheme for Mobile Relays in LTE-A High-Speed Rail Networks," in *IEEE Transactions on Vehicular Technology*, vol. 64, no. 2, pp. 743-756, Feb. 2015, doi: 10.1109/TVT.2014.2322374.
- [3] O. B. Karimi, J. Liu and C. Wang, "Seamless Wireless Connectivity for Multimedia Services in High Speed Trains," in *IEEE Journal on Selected Areas in Communications*, vol. 30, no. 4, pp. 729-739, May 2012, doi: 10.1109/JSAC.2012.120507. Davaasambuu, B., & Sato, T. (2014). A cost based handoff hysteresis scheme in wireless mobile relay node. In IEEE 80th Vehicular Technology Conference.
- [4] Davaasambuu, B., Semaganga, F., & Sato, T. (2015). Adaptive handover hysteresis and call admission control for mobile relay nodes. *International Journal of Computer Networks & Communications*, 7, 87-98.
- [5] Davaasambuu, B., Yu, K., & Sato, T. (2015). Self-optimization of handover parameters for long-term evolution with dual wireless mobile relay nodes. *Future Internet*, 7(2), 196-213
- [6] Lee, D.-W., Gil, G.-T., & Kim, D.-H. (2010). A cost-based adaptive handover hysteresis scheme to minimize the handover failure rate in 3GPP LTE system. In *EURASIP Journal on Wireless Communications and Networking*, 2010. id.750173.
- [7] Mohammad T. KAWSER, Mohammad R. ISLAM, Muhammad R. RAHIM, Muhammad A. MASUD (2017). Versatile Controllability over Cell Switching for Speedy Users in LTE HetNets. *Radioengineering*, 26, NO. 1,(2017), pp.179-190. DOI: 10.13164/re.2017.0179.
- [8] Dimou, K., Min, W., Yu, Y., Kazmi, M., Larmo, A., Pettersson, J., . . . Timner, Y. (2009). Handover within 3GPP LTE: Design principles and performance. In *2009 IEEE 70th Vehicular Technology Conference (VTC 2009-Fall)*, 1-9.
- [9] Wang, Y.-H., Huang, G.-R., & Tung, Y.-C. (2014). A handover prediction mechanism based on LTE-A UE history information. In *Computer, Information and Telecommunication Systems (CITS)*.

- [10] Ge, H., Wen, X., & Zheng, W. (2009). A history-based handover prediction for LTE systems. In *1st international symposium on computer network and multimedia technology*. Wuhan.
- [11] Tao, M., Yuan, H., Hong, X., & Zhang, J. (2016). SmartHO: mobility pattern recognition assisted intelligent handoff in wireless overlay networks. *Soft Computing*, 20(10), 4121-4130
- [12] Luan, L., Wu, M., Shen, J., Ye, J., & He, X. (2012). Optimization of handover algorithms in LTE high-speed railway networks. *International Journal of Digital Content Technology and its Applications*, 6(5), 79-87.
- [13] Watanabe, Y., Matsunaga, Y., Kobayashi, K., Sugahara, H., & Hamabe, K. (2011). Dynamic neighbor cell list management for handover optimization in LTE. In *2011 IEEE 73rd Vehicular Technology Conference (VTC Spring)*, Yokohama
- [14] Chang FM., Wang HL., Hu SY., Kao SJ. (2013) An Efficient Handover Mechanism by Adopting Direction Prediction and Adaptive Time-to-Trigger in LTE Networks. In: Murgante B. et al. (eds) Computational Science and Its Applications – ICCSA 2013. ICCSA 2013. Lecture Notes in Computer Science, vol 7975. Springer, Berlin, Heidelberg. https://doi.org/10.1007/978-3-642-39640-3_20
- [15] Wang, HL., Kao, SJ., Hsiao, CY. *et al.* A moving direction prediction-assisted handover scheme in LTE networks. *J Wireless Com Network* **2014**, 190 (2014). <https://doi.org/10.1186/1687-1499-2014-190>
- [16] Su, D., Wen, X., Zhang, H., & Zheng, W. (2010). A self-optimizing mobility management scheme based on cell id information in high velocity environment. In *2010 Second International Conference on Computer and Network Technology*. Bangkok
- [17] Wang, Q., Ren, G., & Tu, J. (2011). A soft handover algorithm for TD-LTE system in high-speed railway scenario. In *2011 IEEE International Conference on Signal Processing, Communications and Computing (ICSPCC)*, 1-4.
- [18] Lee, H., Son, H., & Lee, S. (2009). Semi-soft handover gain analysis over OFDM-based broadband systems. *IEEE Transactions on Vehicular Technology*, 58, 1443-1453.
- [19] Lee, C.-W., Chuang, M.-C., Chen, M. C., & Sun, Y. (2014). Seamless handover for high-speed trains using femtocell-based multiple egress network interfaces. *IEEE Transactions on Wireless Communications*, 13(12), 6619-6628.
- [20] Anas, M., Calabrese, F., Mogensen, P., Rosa, C., & Pedersen, K. (2007). Performance evaluation of received signal strength based hard handover for UTRAN LTE. In *IEEE 65th Vehicular Technology Conference (VTC2007-Spring)*, 1046-1050. IEEE.

- [21] Link, C.-C., Sandrasegaran, K., Ramli, H., & Basukala, R. (2011). Optimized performance evaluation of lte hard handover algorithm with average RSRP constraint. *International Journal of Wireless & Mobile Networks (IJWMN)*
- [22] B. Soret, K. I. Pedersen, T. Kolding, H. Kroener and I. Maniatis, "Fast Muting Adaptation for LTE-A HetNets with Remote Radio Heads," in IEEE Global Communications Conference (GLOBECOM), 2013.
- [23] K. I. Pedersen, F. Frederiksen, C. Rosa, H. Nguyen, L. G. Uzeda Garcia and Y. Wang, "Carrier Aggregation for LTE-Advanced: Functionality and Performance Aspects," *IEEE Communications Magazine*, pp. 89-85, June 2011
- [24] "ETSI TR 125 913 "Requirements for Evolved UTRA (E-UTRA) and Evolved UTRAN (EUTRAN)", " 2009.
- [25] A. Bedekar and R. Agrawal, "Optimal Muting and Load Balancing for eICIC," 2013 11th International Symposium and Workshops on Modeling and Optimization in Mobile, Ad Hoc and Wireless Networks (WiOpt), May 13-17, 2013.
- [26] D. López-Pérez, X. Chu and Güvenç, "On the Expanded Region of Picocells in Heterogeneous Networks," *IEEE Journal of Selected Topics in Signal Processing*, vol. 6, pp.281-294, June 2012.
- [27] "Telecom's 5G revolution triggers shakeup in base station market". *Nikkei Asian Review*. Archived from the original on April 21, 2019. Retrieved April 21, 2019.
- [28] 3GPP TS 23.401 v14.4.0. General Packet Radio Service (GPRS) Enhancements for Evolved Universal Terrestrial Radio Access Network (E-UTRAN) Access (release 14); 2017.
- [29] 3GPP. LTE Compatible Commercial Mobile Alert System. tech. rep., 3GPP; 2010; Washington DC. <https://www.3gpp.org/news-events/partners-news/1130-LTE-Compatible-Commercial-Mobile-Alert-System>
- [30] "LTE Mobility Enhancements" Qualcomm 2012