

Internship Report on the MWS program of ShopUp



Submitted to

Islamic University of Technology

In partial fulfillment of the requirements for the degree of

BBA in Business and Technology Management (BTM)

I understand that my final report will become part of the permanent collection of the Islamic University of Technology BBA in Business and Technology Management Program. My signature below authorizes release of my final report to any reader upon request.

SUBMITTED BY

Md Mushfiqur Rahman Khan

STUDENT ID

170061021

2020-2021 SESSION

DEPARTMENT OF BUSINESS AND TECHNOLOGY MANAGEMENT

ISLAMIC UNIVERSITY OF TECHNOLOGY

Approved by
Naznin Akther

ASSITANT PROFESOR

DEPARTMENT OF BUSINESS AND TECHNOLOGY MANAGEMENT

ISLAMIC UNIVERSITY OF TECHNOLOGY

Letter of Transmittal

6 April 2022

Naznin Akther
Internship Supervisor
Islamic University of Technology

Subject: Submission of Internship Report.

Dear Madam,

I am very glad to submit my internship report on **ShopUp Limited**. This report is an outcome of my internship program at the company which was of 3 months. It gives me immense pleasure to complete my Internship successfully and submit this report on the experiences that I have gathered during that period.

Working in an amazing company has given me the opportunity to experience a real life work environment. The report will try to give a clear picture of comparison of limited theoretical knowledge and mostly application of such knowledge base.

It would be very kind of you to examine my report work and enlighten me with further suggestions to enhance my clarification.

Sincerely Yours,

Md Mushfiqur Rahman Khan
ID-170061021

Acknowledgement

In preparing this report, I got support from my faculty Naznin Akther madam. That was a great advantage for me. I would like to thank ShopUp Ltd. who helped me sincerely from every respect. I am thankful to a number of people for their kind endorsement, direction and support by providing me the information presented here.

First of all, I would like to thank almighty Allah for this incredible experience. It was also a great experience as my company supervisors assisted me and helped me write this report by giving valuable advice and instructions. Although I had tried to give my utmost to make this report as accurate as possible due to lack of time this might have not been possible.

So lastly I would like to express my heart full thanks to Islamic University of Technology for giving me valuable guidelines related to the report.

Executive Summary

This report has been prepared as a requirement of the internship program under the business and technology management department of Islamic University of Technology. This internship program has been a great experience as I was able to learn a lot of things from experienced professionals at ShopUp.

My internship started from November 1, 2021 to February 1, 2022 which was an incredible journey that helped me to understand how B2B ecommerce works. The scope of the report is to share my experience and recommendation about the company.

ShopUp is a startUp in the ecommerce sector. The e-commerce sector in Bangladesh currently is blooming and there is right now a huge opportunity for growth. The E Commerce sector can further be divided into business to business, business to customer, etc. ShopUp mainly focuses on the Business to Business sector. Bangladesh's business to business sector is still in its initial stages and ShopUp right now is the market leader and has been able to grow at a remarkable rate.

I had to work in the operations team in the MWS project. I have written a detailed discussion on the process of MWS and how the sales team is managed and what sort of reports are generated. Furthermore, the working condition as well as the culture was also described.

My main duty was to increase sales by implementing and executing strategies that would increase sales. I had to generate several reports each day to monitor the progress and follow up with the field team. The report contains a detailed analysis of the company and industry and This is followed by my recommendations for this company which I believe if implemented will boost the company's probability of success.

Table of Contents

Letter of Transmittal	I
Acknowledgement.....	II
Executive Summary	III
List of Figures	VI
List of Tables	VI
Introduction	1
Chapter 1 Company Overview	3
1.1 Description and History of ShopUp.....	3
1.2 Values of ShopUp.....	5
1.3 Business Wings of ShopUp Limited	6
1.3.1 Mokam -:.....	6
1.3.2 Redx-:	8
1.3.3 Baki-:.....	10
1.3.4 Paywell	11
1.4 Organizational Structure of Mokam, ShopUp Limited	13
1.5 SWOT Analysis of ShopUp Limited.	14
1.6 Services/Products offered.....	16
Chapter 2 Industry Analysis	18
2.1 Industry Size and Growth Trends.....	18
2.2 Maturity of the Industry:.....	19
2.3 Technological Factors.....	21
2.4 Regulatory, and Legal concerns	22
2.5 Porters five force model.....	23
2.5.1 Threat of New Threats	23
2.5.2 Threat of substitutes.....	24
2.5.3 Degree of Rivalry	24
2.5.4 Bargaining power of Suppliers	24
2.5.5 Bargaining power of buyers	24
Chapter 3 Duties	25
3.1 MWS Operations	25
3.2 Recurring Jobs	27
3.3 Working conditions	31

3.4 Difficulties and Challenges	31
3.5 Experiences gained throughout training.....	32
3.6 Tools that were used while working	32
Chapter 4 Findings.....	33
4.1 Company level:.....	33
4.2 Market Level:.....	34
4.3 Professional Level:	34
Chapter 5 Recommendations.....	35
Chapter 6 Conclusion.....	36
References-:	37

List of Figures

- Figure 1 Mokam Logo 6
- Figure 2 Redx Logo 8
- Figure 3 Baki Logo.....10
- Figure 4 Paywell Logo.....11
- Figure 5 Organization structure of Mokam13
- Figure 6 Industry life cycle model.....19
- Figure 7 Ecommerce growth during pandemic21
- Figure 8 Porters Model.....23
- Figure 9 Structure of MWS operations25
- Figure 10 Operation of MWS.....26

List of Tables

- Table 1 List of top B2B companies.....20
- Table 2 List of B2B ecommerce company Bangladesh.....20
- Table 3 Tools used32

Introduction

The internship program is a nine-credit course that is designed to give final year students practical experience and put their theoretical knowledge to use. In this competitive world having knowledge about business is not enough one must understand how to apply it and there is now better way to do this but to apply what you have learned in a corporate setting.

Islamic University of Technology aspires to create business students who will one day be leaders in their chosen sector and hence it is crucial that they have both theoretical and practical understanding of the workplace. This is the main objective behind the internship course and this report in the final presentation of the experience gathered in the past three months. The internship course and its report are important steps in achieving the objective.

I joined ShopUp (BD) Ltd to finish my internship project. Shop is a startup company making it an ideal place to learn about entrepreneurship, business development and learn about the ecommerce industry. ShopUp has a wonderful work culture and a friendly work environment. From day one I was supported by my colleagues.

ShopUp although a startup has seen huge growth recently and has been able to secure a investment worth 75 million dollars. ShopUp primarily has a vision to become a unicorn and aims to do that by serving retailers by providing them product at wholesale cost. ShopUp also has a courier business with RedX and Mobile financial service business with Paywell.

In this program I was part of the MWS operations team. MWS meaning Mokam whole sales shop is a project to develop distribution network through hiring dealers. My primary responsibilities were to ensure Standard operating procedures were followed by the sales staff, generate report to analyze sales and try to create strategies to increase sales. I have also had the opportunity to observe the task that was done by the sales team and understand the distribution business.

In my time at ShopUp I was able to find many tasks that are done exceptionally well and many task that could be improved for better results I have described those results in the report furthermore I provided several recommendations that I believe if implemented will produce significant outcomes for the company.

Chapter 1 Company Overview

1.1 Description and History of ShopUp

The Company started its journey from mid of 2017 with Afeef Zubair Zaman (CEO), Siffat Sarwar (Chairman) and Ataur Rahim Chaudhary (CTO) being the founders. At first ShopUp was in the e-commerce industry and primarily helped small businesses by providing tools and small loans to help them carry out their business in a hassle-free way. Over the years although the means of doing business has changed the goal remains the same which is to help and empower small businesses through digital means.

ShopUp began its journey with an angel investment of \$120,000. The company gained \$20.5 million from Sequoia Capital India and Flourish Ventures, with additional participation through VEON Ventures, Speed invest, and Lonsdale Capital (Singapore). Later, the company gained \$75 million in investment from Valar Ventures. Summing up, the company raised \$103.4 million in investments until now.

ShopUp legally known as Shopfront ltd. has a mission to make life simpler for small retailers by empowering them by providing solutions through digital means. ShopUp does this through a number of ways including providing credit, logistics service and Business to business solutions. Objective here is to give full-stack business solutions for small businesses.

Through Shopup entrepreneurs are able to start their businesses and are generating good amounts of revenue. Unlike traditional financial institutions there are no such hassles when dealing with ShopUp. ShopUp takes pride in ensuring customers are satisfied and they're able to serve their customers effectively.

Right now, ShopUp is the highest and fastest-growing company in Bangladesh. ShopUp has over 10,000 employees and is now operating in every district in Bangladesh. ShopUp RedX is known as the best last mile logistics provider and ShopUp's Mokam has already been able to capture the title of being the largest business to business e-commerce site.

1.2 Values of ShopUp

→ Merchant First:

The number one Value taught at ShopUp is to always prioritize our Merchants. Whenever a decision is made prioritizing Merchants', needs should be at the top of the list. Merchants are the customers of ShopUp so satisfying merchants will ensure success.

→ Do more with less

Employees should have the willpower and mindset to be ready to compete with competitors who have more resources than them and give better results by doing more with less resources.

→ Pace Over Perfection

ShopUp being a startup needs to show visible progress and result which means task and actions need to be completed at lightning speed hence sometimes perfection must be sacrificed to ensure deadlines are being met and the company is progressing as fast as it should.

→ Own Your Number

This value teaches employees to take ownership and give results. This teaches employees to hold oneself accountable to the numbers which could be sales data or other key indicators and try to give. This also tells us that the company likes to see progress via numbers.

→ Disagree and Commit

This value emphasizes the importance of voicing decent before a decision has been made But once a decision has been made every member should commit to it and work hard to successfully carry out the plan.

1.3 Business Wings of ShopUp Limited



Figure 1 Mokam Logo

1.3.1 Mokam -:

Mokam can be described as the heart of ShopUp. ShopUp main ambition of trying to make retailers life easy begins with Mokam. Mokam Currently is the biggest BTB ecommerce store (Mokam, n.d.). The business connects Wholesalers with retailers. Mokam Supplies products at an affordable price to retailers by buying from the best wholesalers. Mokam is at its core a distribution. However what Mokam wants to do and how it plans on executing it is new. Due to its perspicuous strategic and tactical plan Mokam was able to get this massive investment.

Through Mokam's app the retail businesses can order over 10,000 products. both branded and unbranded products are available. Mokam aims to provide this product at a very reasonable price and is able to serve all its customers a wide array of products. To accomplish this Mokam has several business units that concentrate on gathering and onboarding the best suppliers and building a strong relationship with them. This means Mokam does business with the largest producers in Bangladesh. Indeed because of this Mokam operation needed this large investment.

Mokam's plan of serving Merchants all over the country would not be possible without a large distribution network. Mokam already has a retail and dealership network in 50+ districts and is currently working to cover all of Bangladesh. Mokam right now already has the largest distribution network of any company and Mokams gross sells is now more than Unilever.

Since Mokam has a huge operation that serves a huge market. Mokam is broken down to several key strategic Business Units that are described below.

- Mokam Commodity

→ Wholesale: Through the Wholesale team Mokam is trying to serve the wholesale sector. The Business unit is responsible for buying huge amounts of products at wholesale price from the producers and then selling it to local wholesalers at a margin. The wholesale team usually delivers the products to its customers after which payment is made. The wholesale operation has been exceeding very rapidly. The company aims to start its wholesale operation throughout Bangladesh.

→ Retail: The retail operations are further broken into two operations. Pure retail and MWS. Pure retail or traditional retail operation is basically like any other retail operation that exists in Bangladesh. That is, a Sales representative takes orders from the customers and then in the following day delivers them. The company has to rent out warehouses and deliver those products.

On the other hand MWS operation is similar to traditional dealerships where products are sent to dealers and the Sales representative takes orders and the dealer is responsible for delivering the products. This is known as ready-sell as products are delivered on the same days as the order is taken.

- Mokam Fresh/Argo

Mokam sells fruits, vegetables and other similar goods through the 'fresh' business unit. Poultry and other meat is sold through Mokam agro. The basic operation is the same for these 2 business units. There exist scouts that search for best wholesalers upon finding these wholesalers products are sourced from them and later on the products are sold to level 3 or level 4 wholesalers. Mokam Agro has been recently expanding and is offering more and more products.

- Mokam lifestyle

Mokam lifestyle deals with fashion and accessories. It is a new operation and still in the process of development. The goal of the business is to be able to source and effectively deliver the common clothing items at a reasonable price. This Business unit has a lot of opportunity for growth and is expected to grow in the upcoming days



Figure 2 Redx Logo

1.3.2 Redx-:

RedX delivery is a logistics business of ShopUp. It is different from other courier services as it uses digital means to better serve the customers. Customers are able to track their product as well as make payment through digital means. This enables customer of Redx to better manage their business and compete much more effectively than before. For instance, businesses will now can better forecast when customers will be receiving their orders and hence increase customer satisfaction.

RedX within a short period of time has been able to achieve huge growth (RedX, n.d.) and is now considered Bangladesh's number one last mile logistic service. Redx now operates in all 64 districts. So RedX now has the potential to serve all of Bangladesh. Redx prides itself on being able to meet the requirement of every single customer and hence provide immense value to their customers.

Redx Uses a hybrid approach to control its operations. Redx uses Trucks as well as Vans to deliver within Dhaka city. These Vehicles are owned by RedX. When delivering Outside the city Redx uses transportation that it rents. Redx Stands out from its competitors by having coverage area that spans throughout the country as well as pricing that is competitive.

The company provides service in Business to Business, Business to customer and person to person. Redx started operating in Bangladesh in 2020 and has a clientele ranging from small businesses to Large multinational enterprises. Redx Especially established its position in the industry as the logistic service for small and medium enterprises that operate ecommerce sites and needs to deliver bulk parcels. As RedX continues to grow the existing models will probably change as larger customers will pick redx as the courier for their business.

RedX has already established a great brand reputation through its brilliant marketing campaign. The vans that Redx use are all coated with the iconic RedX symbol, furthermore the brand logo is drawn in bold in every vehicle that redx operates. Similarly, the uniforms worn by Redx employees are all red with Redx written in black. This has enabled the company to gain massive popularity. Apart from this, the RedX marketing team also ran brilliant marketing campaigns in social media and always post relevant content which makes certain customers are engaged.



Figure 3 Baki Logo

1.3.3 Baki:-

Previously known as 'Digital credits' currently known as Baki is another subsidiary company of ShopUp. Baki can be seen as primarily a special type of financial institution which gives out loans to other business units or customers. Baki primarily provides support to mainly internal business units of the company by providing credit and keeping track of it. Since Baki has the information of overdue from every Business unit of the company effective reports can be generated and key insights about the business can be found

Baki also helps to assess and determine the best BU's to invest in which will give the best rate of return. Baki before giving out loads compares which business units are performing better, that is which business units are achieving their target and how well the overall business is doing in terms of customer satisfaction and using this key metrics determination can be made on which business to invest on. So Baki plays a huge role in strategic planning and tactical decision making.

Baki also ensures minimum fund leakage and raises flags at the earliest red signals. Baki monitors overdues and keeps track of the condition of overdues. Quality reports are generated which notes the reason for overdues and if in certain cases if Baki team finds there might be information which suggest fund leakage or some financial fraud that is going on they are able to escalate the issue through specified channels. Because of these checks Baki has been able to keep financial misconduct committed to a very minimum level.

So for instance if a customer has missed the deadline the customers contact details will already be included in the list of overdues at the same time these details will added to the customers profile so when deciding about doing business with these particular customer in the future these data can give valuable insights about the nature of the customer.

Baki has great softwares and uses the latest technologies that help enable Baki to ensure or keep track of the credit that exists. The softwares can generate reports in an instant. Valuable data such as when has the customer made payments can be seen so that executives can spot if something is going wrong. The software also helps top management see the performance easily and in real time understand where the business is in terms of performance.



Figure 4 Paywell Logo

1.3.4 Paywell

Paywell is the fourth subsidiary company of ShopUp. This is the newest of the 4 companies. Paywell was unlike the other companies acquired by ShopUp. Previously discovered companies all were built up by Shopup but Paywell was bought as it is believed paywell will work well with other companies and significantly bring down the cost of doing business.

Paywell itself is a mobile financial service provider (paywellonline, n.d.). Similar to companies like Bkash and Rocket, the main aim of Paywell is to be able to make monetary transactions digitally no matter where someone is located. Services such as mobile recharge and utility bills are also available through paywells app.

Due to the nature of Mokam's business and the volume of the business using traditional banking is not convenient for suppliers or dealers hence a mobile financial service is required as using third party will result in getting company information being compromised ShopUp decided to acquire Paywell.

Paywell operations right now are increasing rapidly. The company has appointed new staff and the operations are being expanded in new territories and soon Paywell will be covering the whole country. Paywell is now getting recognition from several small retailers and have been gaining popularity among ecommerce site owners

Paywell has already a nice app with most of the features customers would demand from a MFS. This also comes with a user interface that is designed in such a way so that new smart device users will be able to use it. Paywell is available in both Bangla and English. Paywells app is constantly being updated so that more features can be used to attract customers.

1.4 Organizational Structure of Mokam, ShopUp Limited

ShopUp is a startup and organization can still be described as a flat organizational structure. However, as ShopUp is increasing its sales volume and business is expanding this is changing. Although each company's organizational structure is different from one another there are similarities. Below flowchart shows the Organizational structure of Mokam which consists of Sales representative at the bottom of the chain. These Sales representatives are usually temporary workers who have field supervisors who supervise them. The supervisors report to territory sales managers who in turn report to managers. On the other hand, there are executives who usually do more reporting work than field level sales work they also directly report to manager. The manager reports to department Head and the department head reports to Top level Management

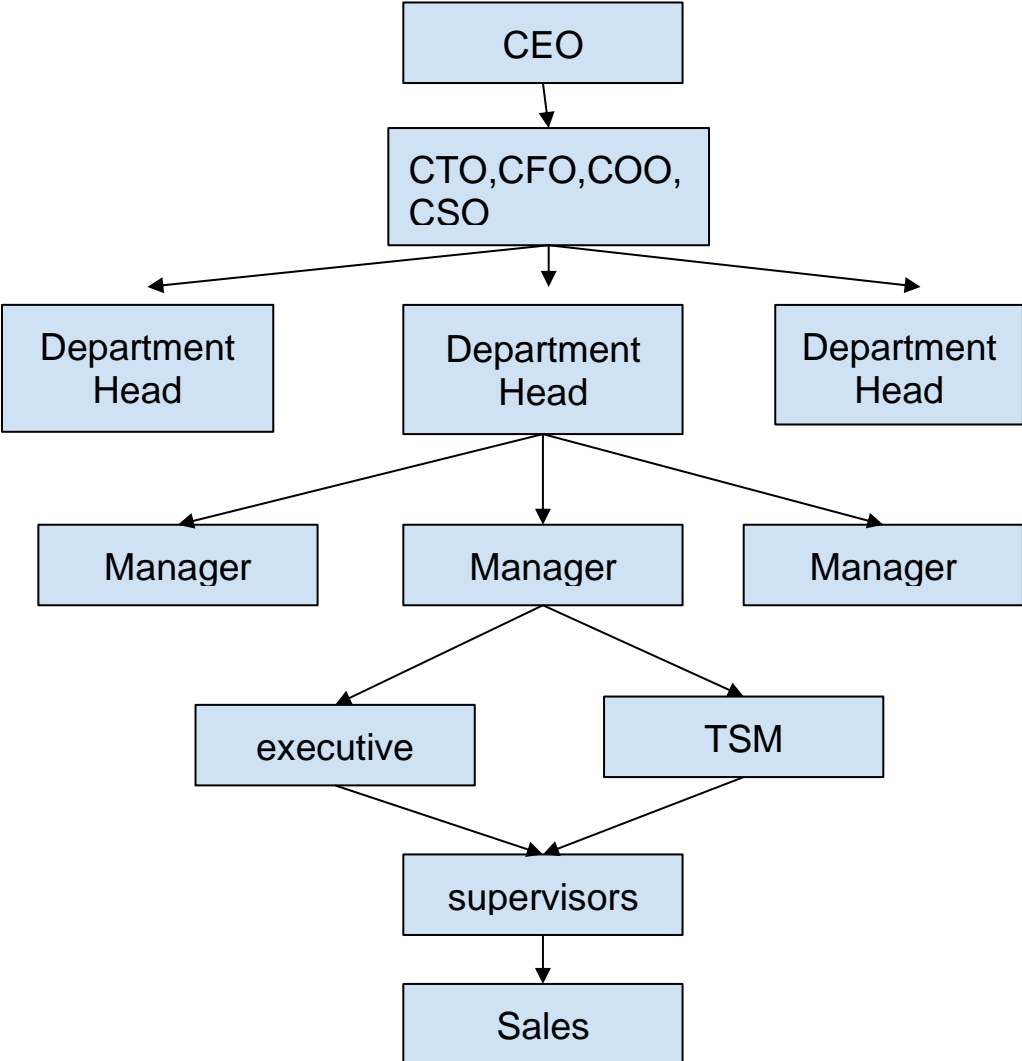

Figure 5 Organization structure of Mokam

1.5 SWOT Analysis of ShopUp Limited.

SWOT analysis is used to evaluate the position of the company by analyzing Internal Strengths and Weaknesses and also reviewing external condition by considering Opportunities and Threats. (Kaplan & Norton, 2008)

Strengths:

The employees are competent, motivated and energized. The company enjoys a strong financial position thanks to the huge investment. ShopUp has a very unique business model which enables it to expand at good speed. Being the largest B2B e-commerce business ShopUp Mokam enjoys a good image in the industry. Furthermore, ShopUp employs the latest technologies to gather and analyze data which helps increase visibility and helps to be more competitive. ShopUp has been able to establish a large distribution network and already has a large customer base.

Weaknesses:

Since the company is expanding at a very rapid rate in some cases operations are not as efficient as it could be. Being an E Commerce company the success of ShopUp largely depends on whether merchants will be able to use the app and whether they prefer using it over the traditional options. Much more sophisticated tools will need to be used for better trend analysis. Cross departmental work is not effective. Employee retention rate is quite low. Competent employees are leaving the company due to poor compensation.

Opportunities:

ShopUp can expand in any market it wishes to as there are few competitors right now. ShopUp can continue diversifying its products and increase the number of categories being sold. ShopUp has a great brand Image and can form effective partnerships with businesses to further increase customer base. ShopUp's business model is very unique and in the future ShopUp can start its operations in other countries.

Threats:

E-commerce is a very lucrative industry hence there may be new competitors who will challenge ShopUp in these markets. Currently due to Eyal's scandal people are skeptical of e-commerce companies and this might negatively affect ShopUp.

1.6 Services/Products offered

Mobile Financial service:

Through Paywell App Shopup provides a number of services to customers. Including recharging sim paying utility bills and transferring money to other wallets. In the future paywell will be increasingly used for making payments.

Distribution:

Wholesale:

ShopUp sells to wholesalers by sourcing products from producers. The category ranges simple items such as fruits and vegetables to more complex its such as clothing and building materials.

Retail:

Shopup has an aim to sell more than 10000 products to retailers through its app. This products will be both branded and unbranded products. Non branded items such as rice sugar oil will be provided at the most affordable price possible along with that branded fmcg items will also be available in the app from several top companies.

Dealership:

Shopup takes dealerships of popular Fmcg companies and then using its vast distribution network distributes the product to retailers and ensures maximum sales.

Courier:

Through Redx shopup provides courier service to businesses. Currently Redx is the number one choice for medium and small enterprise. Large businesses are also picking Redx's service for their business.

Loans:

Shop up provides businesses with small loans. Since small enterprise are usually do business with small working capital this usually makes doing business a lot easier. Furthermore the process of getting loans with ShopUp is less cumbersome. So customers keep choosing shopup to do business with.

Chapter 2 Industry Analysis

2.1 Industry Size and Growth Trends

According to Facts and Factors, the global business to business e-commerce was estimated to be around USD 7.35 Trillion in 2020 (globenewswire, n.d.) ,the new projections show by the end of 2026 the revenue generated will be around USD 18.57 Trillion, with a Compound Annual Growth Rate of 18.70% between 2021 and 2026

According to grad view research (Grandview Research, n.d.) The global B2B e-commerce market is expected to climb upto USD 25.65 trillion by 2028 this means the growth rate will be around 18.7% from 2021 to 2028.

The global ecommerce market witnessed increasing sales recently due to coronavirus (Bhatti). Due to restriction placed by local authority lots of businesses have started using online or digital means to sell their product and due to more people using smart devices than ever before consumer habit is changing and more and more people are now willingly adapting to buying goods through ecommerce sites.

A German firm recently predicted Bangladesh's e-commerce sales will more than double in the upcoming days as the youth of the country are tech savvy and more people are using smart devices the revenue generated by ecommerce platforms will more than double

According to Statista Bangladesh now ranks 46th in the global ranking when it comes to revenue generated by e-commerce, the total revenue generated by ecommerce has been said to be over 1 billion dollars.

2.2 Maturity of the Industry:

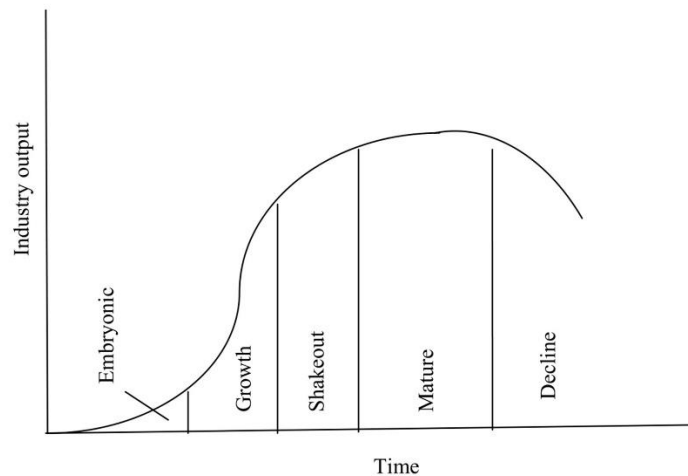

Figure 6 Industry life cycle model

In the industry life cycle model, the B2B ecommerce industry falls in the growth stage and the B2C ecommerce industry can be said to be in the shakeout stage. In the growth stage the industry is usually sees high growth rate and more competitors rising. This is true for global B2B industry.

The majority of the sales are done by the top companies. It has been estimated around 58% of the sales are done by the top 5 companies. The global BTB e-commerce although is seeing increasing competition as more and more competitors are joining to

The following companies are examples of global companies that are leading

Serial.	Company Name	Country
1	Alibaba	China
2	ChinaAseanTrade.com	China
3	DIYTrade.com	China
4	eBay Inc.	USA

5	eworldtrade.com	USA
6	Flexfire LEDs	USA
7	Flipkart.com	India
8	IndiaMARTInterMESH Ltd.	India
9	KellySearch.com	USA
10	KOMPASS	France

Table 1 List of top B2B companies

In Bangladesh the industry is still in the embryonic stage. The growth rate is modest and significant investment is needed to create the market for the market to be ready. The following is a list of top BTB e commerce companies in Bangladesh (The Financial Express, n.d.)

Sl	Company name
1	ShopUp
2	Malamal
3	Sinbaad

Table 2 List of B2B e-commerce company Bangladesh

B2B e-commerce in Bangladesh is new and ShopUp has the majority of the market under its control. This industry will see continuous growth in upcoming days as more and more businesses turn to digital means for sourcing solutions. Right now, B2B landscape is at its infancy and ShopUp will be able to enjoy the first mover advantage.

2.3 Technological Factors

Through advancements in technology now businesses can order products online and make payments through online means (York, 2000). This reduces a lot of paperwork that would traditionally be needed and saves time and effort that can be used elsewhere. Previously or traditionally checks or cash was to be used to make payments and these not only waste time but were riskier than the digital means offered by online B2B platforms.

Online trading also allows data to be shared and last-minute changes to order being made which could potentially impact the bottom line in a drastic way. For example, if for some reason there is a flaw in an engineering drawing and the business is able to review and change the order through digital communications it can save businesses from re-ordering the whole order and saving them huge sums of money and of course time.

In some cases, Suppliers are treated as key strategic partners and information is shared back and forth so demand can be better forecasted, delivery times shared are more accurate and the quality of goods are up to standard. This will make the business more efficient compared to their competitors.

As technology gets developed more people will use smart devices and will more likely use internet to do business. Technologies such as 5g have already been developed and this is expected to boost the adoption of ecommerce. Already due to pandemic we can see adoption rate of ecommerce have increased (impact-covid-pandemic-ecommerce, 2021)

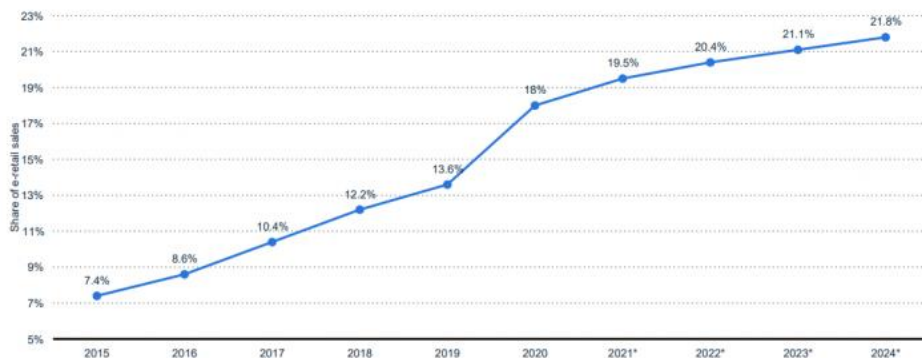

Figure 7 Ecommerce growth during pandemic

2.4 Regulatory, and Legal concerns

The existing laws in Bangladesh don't really cover the ecommerce industry as well as it should. There is already a movement among lawmakers and industry experts who seek to build a framework which will protect the rights of consumers who are buying products from these ecommerce sites

If new laws are enacted these might make it difficult for ecommerce site to carry out business. Since in Bangladesh the government agency are quite inefficient and lengthy wait times are inevitable. Since start up requires growth and hence the business is quite fast paced if laws such as these are passed then it will have a negative effect on the business

2.5 Others

There is an increasing risk of cyber-attacks. Experts at cybercrimes suggest there will be more cyber-attacks in the future. companies will be required to have experts that can help prevent such attacks and to ensure proper defense of the system. This will likely hinder the growth of the industry.

2.6 Porters five force model

Porters five force model helps to analyze companies' external environment (Porter, 1979).



Figure 8 Porters Model

2.5.1 Threat of New Threats

The ecommerce industry will grow in the upcoming days. The market size is going to more than double within a couple of years. New entrants will be vying for share of the market. Since the industry hasn't matured and the barriers to entry are primarily large investments, ShopUp should expect new competitors in the future.

2.5.2 Threat of substitutes

The substitute of Ecommerce BTB is physically buying and selling of goods between business. There is a slim chance of people reverting back to the old forms of how business is done. The possibility of this happening is quite low and ecommerce has several advantages over the traditional forms of business

2.5.3 Degree of Rivalry

The degree of rivalry ShopUp faces is quiet low; the primary rivalry are from local wholesalers. However, since ShopUp has the monetary capabilities, it can buy directly from suppliers and deliver it at a lower cost then its competitors at the same time ShopUp has the monetary power to outlast the local wholesalers even if it has to resort to under rating. Another key competitor is Sinbaad however the startup doesnt have such a high investment as shopup.

2.5.4 Bargaining power of Suppliers

The Bargaining power of suppliers differ greatly depending on the product they supply. For example, a rice supplier will not have as strong of a bargaining power as JTI. Since JTI has brand reputation and finding substitutes for JTI will be difficult and customers will want ShopUp to source JTI products. Basically, those FMCG brand with good reputations that customers really want their product of has good bargaining powers.

2.5.5 Bargaining power of buyers

The customers of Shopup are the retailers if shopUp is not able to provide at the price that is affordable, the customers can go to other platforms or buy through traditional channels. So Shopup must try to keep the prices at a minimum in order to satisfy its customer

Chapter 3 Duties

3.1 MWS Operations

I was an intern for the Mokam Wholesale Shop team. The main aim of the team is to develop a distribution network through dealers(The MWS is basically the warehouse of the dealer where he keeps the product). Traditional retail operations usually covered the urban areas whereas the rural areas were left to MWS operations. The following summarizes the sales force team.

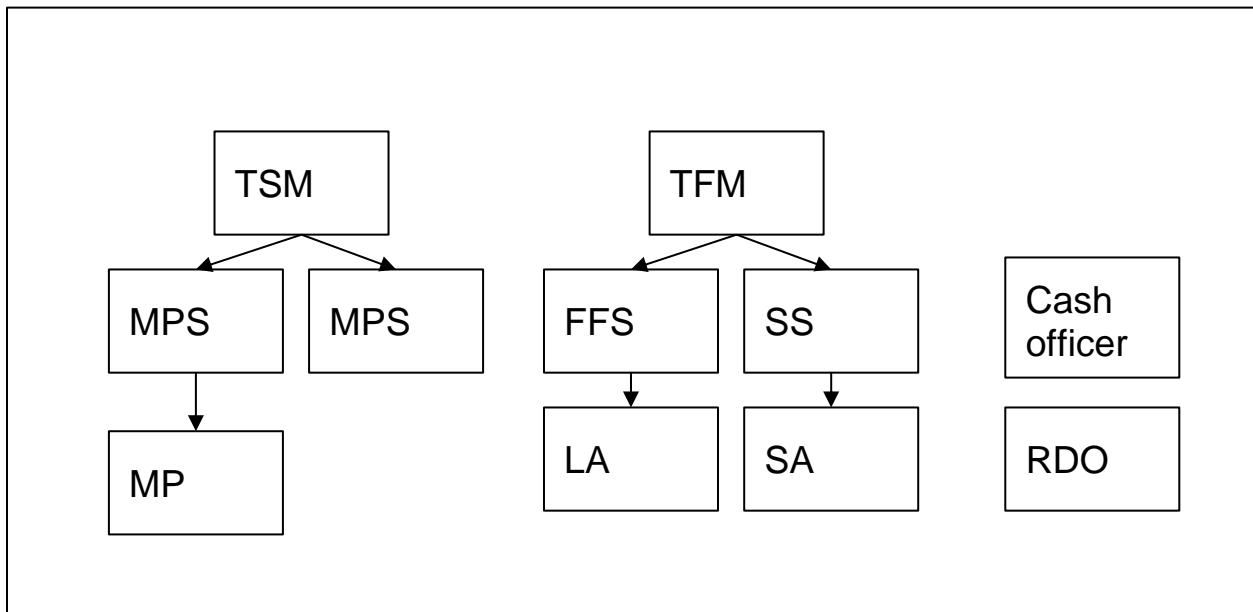

Figure 9 Structure of MWS operations

TSM Supervises the sales team. Under TSM there is the Mokam Partner supervisor (MPS) who supervises the Mokam Partners (Sales Representatives). The main task of SR is to ready sell the products that are present in the MWS.

TFM is responsible for sourcing and fulfillment. TFM manages Fulfillment supervisors (FFS) and Sourcing Supervisor (SS) . FFS delivers products to each MWS through LA (Logistic Associates)

and the Sourcing supervisor is responsible for sourcing the best products from suppliers. Sourcing supervisors manage Sourcing Associates(SA) who goes to suppliers and gets quotations and later buys from them.

Cash officer is the designated finance officer for the zone and RDO is the Human resource officer who is in charge of recruiting and training staff in the zone.

The figure above summarizes the whole operation of Mokam Wholsale shop. Below i have stated the Daily recurring work that I had to do daily.

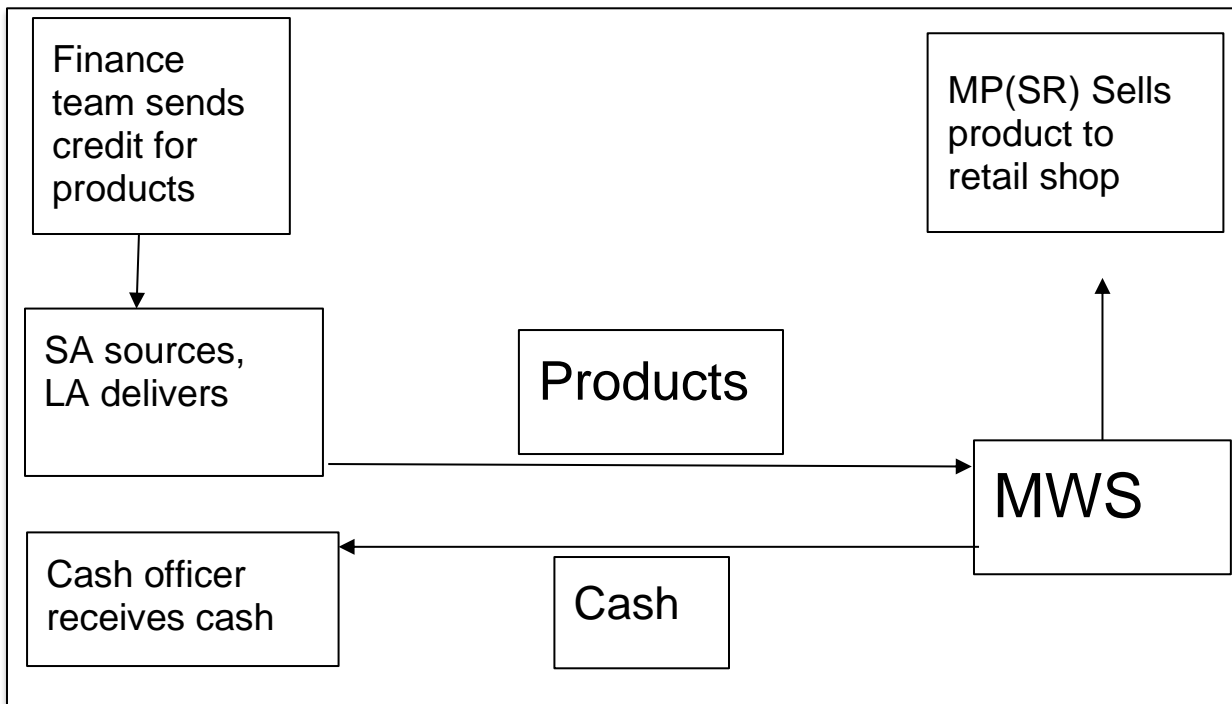

Figure 10 Operation of MWS

3.2 Recurring Tasks

Supervise Sales Team

I was given 12 districts to monitor the sales force team which included Sales Representatives and supervisors and I had to make sure the revenue increases. I Followed up with the sales team by calling them. I asked several questions on why their performance was not upto the standard. If acceptable reasons were not received the names of those Sales representatives were marked so that if pattern of behavior keeps occurring actions can be taken.

On the app there is a feature where Sales representatives have to mark attendance everyday before beginning their work and have to mark and deliver all the items that they got orders of. I had to compile a list of all those Sales Representatives who had failed to comply with Standard Operating Procedure and ask them why they had failed to do so. If satisfactory answers were not received the matter was escalated to the manager.

Generate Sales reports

Daily/Weekly Reports were made to catch key insights of the business. One of the reports was the revenue generated from each Sales Representative. The report showed the sales figure for each day and also showed when the order was placed. Simply by looking at the data we could tell who was working and who was slacking off. The report also included the number of retail each Sales representatives had visited.

Another report was on category liquidation. That report showed how much revenue was generated from each category of product and for each zone what were the top category of products. The report also showed the difference or trends in consumption of each MWS.

Diagnose problems

Sales force team often ran into problems with tech, with our dealers or other problems such as sourcing. The main problem that frequently comes up is dealers do not understand how commission is calculated so they often have a dispute with supervisors about it. So, we have to hold meetings with the dealer and make them understand what our policies are and how much we are willing to pay.

Second problem that frequently comes up is transportation problem. Transportation problem can be of several types sometimes it might be a problem related to hiring trucks other times it can be something much complicated which I have to collaborate with the logistics team to solve.

Make sure Shipment challan and cash collection slip is updated

Every time Shipments of products are sent to a MWS a shipment challan must be signed by the dealer and then uploaded to a database. The supervisors in charge sometimes due to carelessness, forget to upload it so I have to call them and remind them to follow our operating procedure and upload those documents.

Similarly, once the Shipments are sold the cash is collected and received by the cash officer. They then upload the documents to the database. Once this data is received it baki team clears the dues and updates the file for the respective dealer.

Monitor overdues

Each time shipments are sent to MWS. they are sent as credit hence called dues. The working capital should have a turn rate of 5 days. After that it is described as overdues. Everyday at the end of business day baki team generates a list of dealers with significant dues and the next day i have to call each Sales representative that works for the dealer and understand why they are not able to covert the dues to cash.

Sometimes fraudulent activities can be found. Example Sales representative after selling the product did not send the money to cash officer or the MWS owner fraudulently took cash. If such incidents were found this had to be reported to senior level management.

Hold meeting with dealers

Dealers often get into dispute with the sales force team. The matter of dispute may range from commission to behavior related problems. Since shopUp has a policy off merchant first we have to patiently have to hear what the dealer has to say and then offer a solution which can be for example changing the sales representative or some sort of compensation etc.

Mapping location of MWS

Every location data is taken from the field team and inserted into a database. Then from the database the coordinates are marked in the google maps app for business using these routes as well strategic business decisions can be taken. Through Google maps the approximations between each MWS can also be seen and this can be used when planning where to increase operations. The google Maps also helps to visualize the different problems that the transportation team might face when delivering the product.

Determine routes

To run MWS operations successfully the routes should be chosen so that at minimum three MWS can be run on that route. This helps to reduce the average transportation cost. Technology is used to map the MWS in google map which is used to plan routes where trucks will be sent with shipment. The routes were designed in collaboration with transport manager. When designing routes, it was made sure the new routes were feasible that is the transportation cost is to be made as low as possible.

Mokam App training

Mokam uses three apps. The field force often needs training in order to successfully use those apps properly. Training sessions are held to make sure they understand every crucial detail of the app. The training was held virtually and usually consisted of no more than 30 or Sales representative from 5 zones. Later the Sales force was strictly monitored to make sure the app was used as intended and if required retraining was done.

Shipment checking

To ensure the fulfillment supervisors are using the app properly I have to call them and make sure they are showing shipments in the app when actual shipments are being sent this can be ensured by getting data from the field team of how many shipments are being sent and according to that generating report of mismatch between app and reality. The supervisors who often failed are given a show cause notice.

Giving Access

Each app is designed in such a way to make sure only authorized person is able to use it. So individually every authorized person has to be given access. Access is given by sending a OTP to the mobile phone number of authorized personnel. Once access is given the person then can use the app to place order, update price send shipment etc.

3.3 Working conditions

The operating hour for ShopUp is 10' o'clock to 6' o'clock. Because of the nature of our business, there was always some tasks that needed to be completed during the evening, hence overtime wasn't uncommon. However, Management is going to take steps to reduce the working hours in the future employees will only need to work 5 working days per week instead of 6 and employees will be able to apply for half day which is being able to leave after working for 4 hours.

The working conditions were quite nice. The office was new and there was an air conditioner and seats were also brand new. The office staff kept the office neat and clean. There was always coffee, tea and snacks available. The lunch break was flexible, that is there was no particular time set for lunch whenever one wanted to eat their lunch they could.

3.4 Difficulties and Challenges

The first difficulty that I faced was the long working hours. Almost every day I had to work overtime to finish the day's work. this is because to make this shipment and delivery report I had to wait till 8-9 o'clock then get data from the field team to make the report which meant I had to stay till late.

Sometimes there was a lot of pressure put on me to quickly get something done which was very challenging to me at first as i am the kind of person who likes to think everything through before actually start doing it. But the urgency of the task prevented me from taking this time so at first i struggled with this type of work

3.5 Experiences gained throughout training.

I have gained several valuable experiences from my training which includes being able to create useful reports. Learn how to follow up on the sales team. I also learned how to set up distribution network and how the sales force is managed.

I have been able to develop m soft skills immensely. I learned which words to use and how should one speak to the sales force to keep them motivated and give the desired results.

I also learned how to write emails and how to conduct meetings with large participants. I have been able to learn how to formally write and respond to emails and which phrases should be used on which occasion for maximum effectiveness.

3.6 Tools that were used while working

Metabase	This is the central data warehouse where all data from sales,shipment,inventory can be found by running different queries.
Excel / Google sheet- Spreadsheet software	Very useful tool to analyze data or organize data to make use full reports.
Microsoft Word	:A word processing tool used to make reports.
Microsoft powerpoint	Useful tool to create presentation slides.
Sr Panel	Panel to give access to SR so that they can use their SR app.
WMS Panel	Through this Panel Supervisor has to send shipment to MWS

Table 3 Tools used

Chapter 4 Findings

4.1 Company level:

- The company uses the latest technology available to collect and manage data. Because of this ShopUp is able to pick up key insights about the market at a quick pace which can then be used to make goods decisions. Use of latest technology also means productivity is being increased so employees are able to give a greater output than they would otherwise be able to. For example: since ShopUp uses google sheets reports can be made and shared in an instant and will not require one to write a mail to send the report
- The company Manages sales force in a very efficient way. The company uses software to track the Sales team and managers can in real time see where each sales representative is and what they are doing.
- The company puts a lot of emphasis on development. Since ShopUp is a startup, it is absolutely essential to show progress in order to get investment and the management hence take decisions rapidly and because of this ShopUp was able to become developed so fast.
- Cross functional synchronizations are very poor. People in various department doesn't work like a team as they should. There is serious levels of communication gaps and cross departmental work flow is slow and erroneous.
- The app developed by the team is not up to the standard. The field team faces several problems while trying to use the app. Because of the complexity of the app the app is not being used as intended.

4.2 Market Level:

- ShopUp is able to become a market leader since the business model of ShopUp is such that they are able to provide items at a cost that local suppliers will never be able to match. Since ShopUp basically controls the whole supply chain beginning from producers to transportation they are able to quickly capture the market.
- ShopUp since it has a large investment can do business in a variety of forms. If required shop up has the funds necessary to provide goods in credit. Since in Bangladesh a lot of retail prefers doing business by credit this is a great.
- The industry is still in its infancy and ShopUp is enjoying the first mover advantage ShopUp already has been able to gather a good reputation and build a huge customer base.
- Due to increasing usage of electronic devices the ecommerce industry will likely see a huge growth and Redx is currently leading courier of choice for small and medium size business owners. Hence in the future it is likely Redx is going to become more and more profitable.

4.3 Professional Level:

- Through this internship I was able to learn about the various ways the sales force is managed. This knowledge can be applied to a number of different industries. Almost all sectors use salesforce and being able to manage them effectively is a crucial skill because at the end of the day sales is what matters the most in the company.
- I was able to learn how to make sure the Standard operating procedure is being followed and have gained valuable knowledge on how to make policies to achieve a desired goal. In the future if I go into the operations department this knowledge will help me greatly.
- As I had managed a sales force directly, I was able to get leadership experience which I will be able to use in my career.
- I had to write several emails and makes several calls every day thus my soft skills have increased greatly.

Chapter 5 Recommendations

ShopUp has been able to achieve a whole lot in a really short time. The business growth and the sales volume speak a lot of how much potential ShopUp has but at the same time some cracks are appearing that if ShopUp doesn't attend to will result in ShopUp losing their customers and suffering huge losses. The following are some recommendations I believe ShopUp can use to better manage their business.

- ShopUp needs to ensure the cross departmental collaboration is better. They can do this by forming key cross functional teams and making top level management aligned so that objectives are met in a timelier manner. There are several key task that are absolutely vital for success when this objectives are not being met finger pointing begins to minimize this and to hold someone accountable cross functional team needs to utilized more of.
- ShopUp must ensure the products that are being sold to the customer are of the highest quality. If the retailers are not satisfied with the products, they are receiving, in the future they will not be willing to do business with ShopUp and this will result in a massive loss. Right now, the check and balance that are in place to ensure quality in minimal and not comprehensive enough to really better the experience of the customer. More needs to be done in this regard such as appointing a quality team to go around zones and monitor the quality of goods being sold.
- ShopUp needs to make a team to monitor customer satisfaction whether retailers are satisfied with delivery, staff behavior and quality of the products must thoroughly be studied. This then can be used to compare different zones and identify the zones which are lacking in this key metrics and take actions to resolve this.
- ShopUp must concentrate on building a better brand image for Mokam. This will in the long run help them capture greater market share. Right now Redx is well known but Mokam has yet to be recognized by the general public.
- The apps that are being designed needs to be a cross departmental effort rather than the job for IT team since ShopUp will rely on its app to bring orders in the future the app must be thoroughly tested and be perfect before it is sent to the customers.

Chapter 6 Conclusion

In this internship I worked with Mokam wholesale shop team to grow the business. I learned about the different business units of ShopUp and learned how they conduct their business. In this internship report I presented all the recurring task that I had to do as well as how the MWS operations was managed further more I tried to describe all the business units and the main vision behind ShopUp.

Through this internship I was able to learn a lot. ShopUp is a startup and hence I gained valuable experience on how startup is managed. I was able to develop my soft skill as I had to do several presentations held meetings and wrote emails. I saw firsthand how experienced professional strive relentlessly to successfully complete objectives.

ShopUp has several advantages from its competitors including a huge investment, a great business model and technology. Being a very unique company with a unique model ShopUp has been able to win huge investment and given how due to the pandemic people have started using ecommerce sites more and more there is huge potential for growth for ShopUp. The projections are also in favor of ShopUp as forecast from renowned companies forecasts large growth in this sector.

However, ShopUp in the upcoming days must concentrate on cross departmental collaboration and make sure there is synergy between the teams. In the upcoming days there will be competitors vying for this market place and in order remain as the number one business organization in the B2B industry ShopUp must do more to maintain this strong brand image.

References-:

- (n.d.). From Shopup : <https://shopup.com.bd/>
- (n.d.). From Mokam: <https://mokam.com.bd/retail/bn>
- (n.d.). From RedX: <https://redx.com.bd/>
- (n.d.). From paywellonline: <https://www.paywellonline.com/>
- (n.d.). From The Financial Express:
<https://www.thefinancialexpress.com.bd/public/trade/shopup-raises-75m-to-become-the-best-funded-start-up-in-bangladesh-1631003717>
- (n.d.). From Grandview Research: <https://www.grandviewresearch.com/industry-analysis/business-to-business-b2b-e-commerce-market>
- (n.d.). From globenewswire: <https://www.globenewswire.com/fr/news-release/2021/11/02/2325466/0/en/Business-to-Business-B2B-E-commerce-Market-Size-to-Grow-Over-18-70-CAGR-to-Reach-USD-18-57-Trillion-by-2026-Globally-Facts-Factors.html>
- Bhatti, A. A. (n.d.). E-commerce trends during COVID-19 Pandemic. *International Journal of Future Generation Communication and Networking*.
- Kaplan, R. S., & Norton, D. P. (2008). *Identifying strengths, weaknesses, opportunities, and threats* .
- Plant, R. T. (2000). *E-commerce: Formulation of Strategy*.
- Porter, M. E. (1979). *How Competitive Forces Shape Strategy*. Harvard Business Review.
- York, F. R. (2000). *What is a Payment System?*