

ISLAMIC UNIVERSITY OF TECHNOLOGY (IUT)
ORGANISATION OF ISLAMIC COOPERATION (OIC)
DEPARTMENT OF MECHANICAL AND PRODUCTION ENGINEERING

Semester Final Examination
 Course Number: MCE 4807
 Course Title: Mechatronics

Summer Semester: 2021 - 2022
 Full Marks: 150
 Time : 3.0 Hours

There are 6 (SIX) questions. Answer all 6 (SIX) questions. The symbols have their usual meanings. Marks of each question and corresponding CO and PO are written in brackets. Formula is provided at the end of this question paper. Show all steps and calculations.

1. a) A mechatronic system can be model according to the schematic diagram in Figure 1. Solve for the damper value, D of the first gear ratio that will generate a 20% overshoot in output angular displacement for a step input. (15 Marks)
(CO 2)
(PO 2)

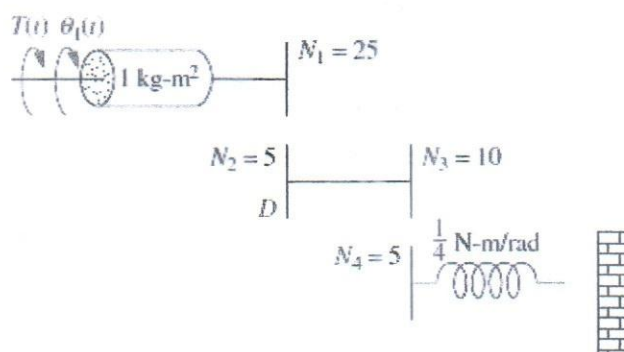

Figure 1: A schematic diagram of a rotational mechanical system with gears

- b) A suitable gear ratio is to be selected for a rotational mechanical system shown in Figure 2. The gear ratio selected is expected to produce the step response in Figure 3. Design for the gear ratio required to meet the system performance requirement. (10 Marks)
(CO 3)
(PO 3)

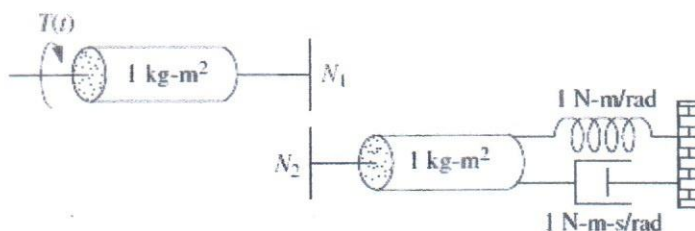

Figure 2: A rotational mechanical system with gears

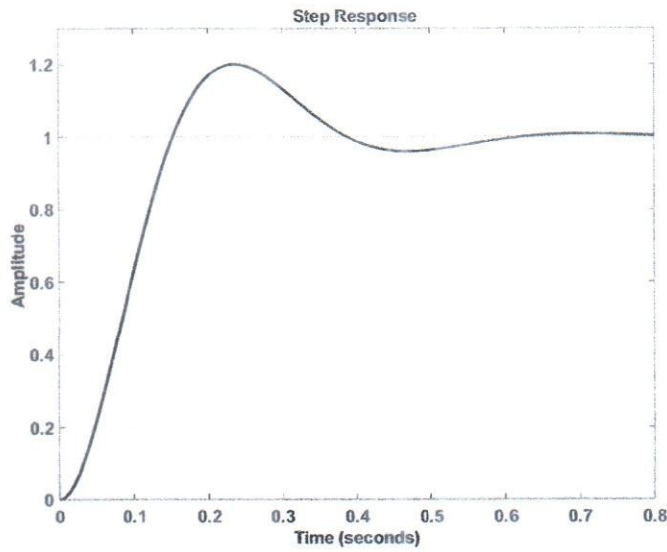

Figure 3: A step response of a mechatronic system

2. Figure 4 shows a block diagram with forward gain, K representing motion control of a mechatronic system. Figure 5 then shows the current step response for this system. Design a suitable controller using the root locus technique that will improve the system transient performance in a way that it halves the settling time while maintaining the percentage overshoot value. Compare the step response results of both the uncompensated and the compensated system. **(25 Marks)**
(CO 3)
(PO 3)

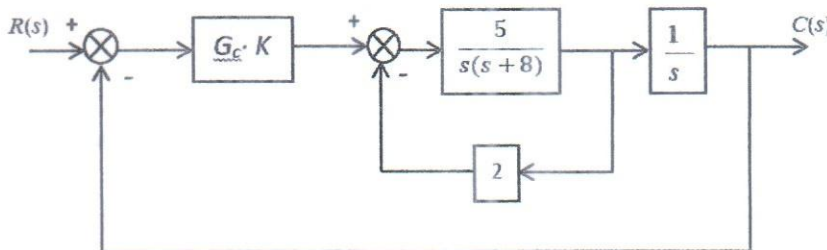

Figure 4: Block diagram of a mechatronic control system

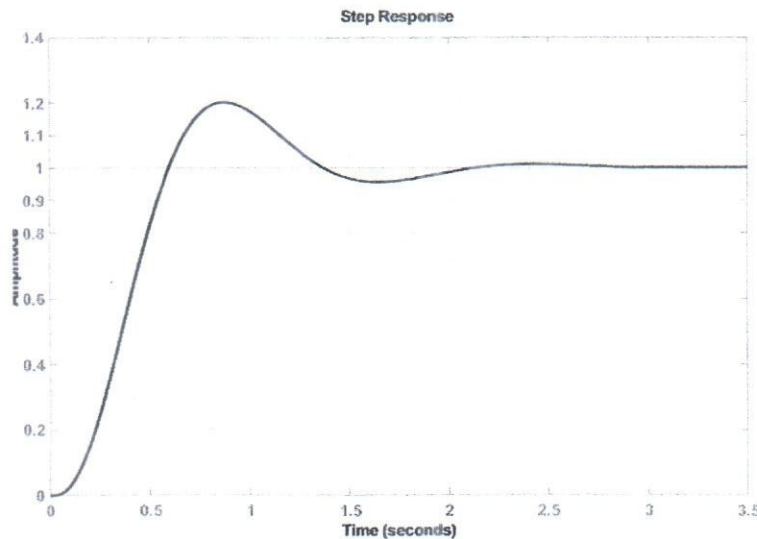

Figure 5: A step response of a mechatronic system

3. Consider the following schematic diagram of a mechatronic system as in Figure 6. The system is to be applied in a manufacturing process activity as a mean of improving the production efficiency and performance. Suggest the type of sensors and measurement system to be applied with this mechatronic application. (25 Marks)
(CO 1)
(PO 1)

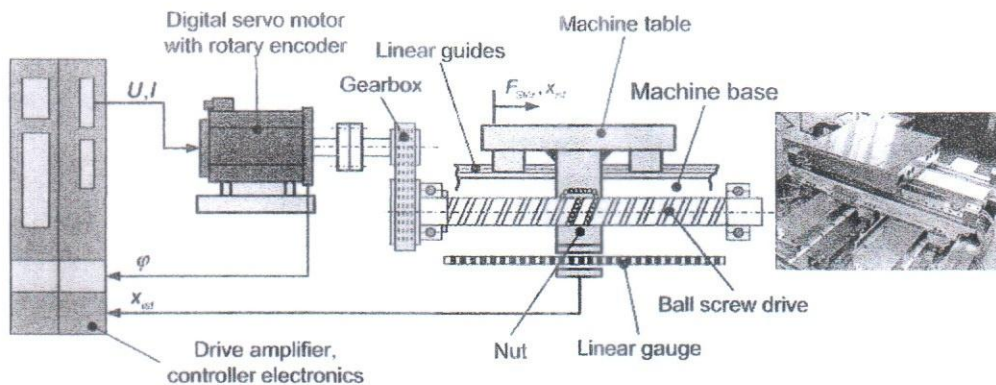

Figure 6: A mechatronic system for manufacturing process automation

4. a) A temperature measurement system is to be designed and constructed for a high temperature furnace application in an automotive parts production and assembly industry. Suggest the type of thermal sensor suitable for this application. Justify your selection and elaborate on the basis of the working principles of the sensor selected. (15 Marks)
(CO 1)
(PO 1)
- b) The performance of the thermal sensor measurement system in (a) is to be evaluated in order to analyse its effectiveness, accuracy and quality of the total production system. Elaborate on the performance criteria requirements in sensor selection process. (10 Marks)
(CO 1)
(PO 1)
5. a) A load cell is applied for the measurement of force in one mechatronic system. Discuss 5 (FIVE) justifications for coupling the load cell with signal conditioning methods. (10 Marks)
(CO 1)
(PO 1)
- b) The basis of many signal conditioning units is operational amplifier. Mars Rover as in Figure 7 is an excellent example of a complex mechatronics system ever developed. Select and elaborate on the working principles of 3 (THREE) types of operational amplifiers that can be part of the sensor measurement conditioning system for the Mars Rover shown. Sketch the schematic diagram of each type of operational amplifiers. (15 Marks)
(CO 1)
(PO 1)

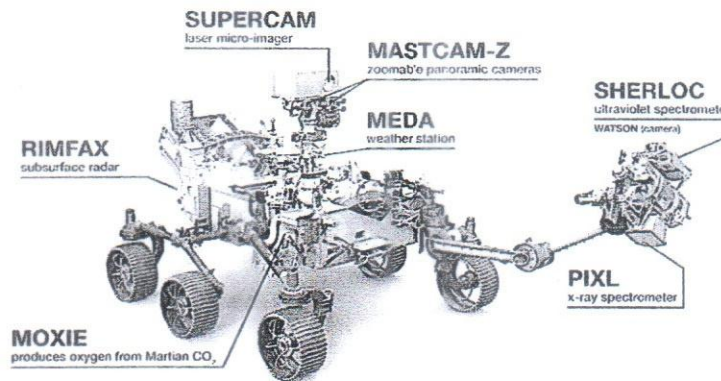

Figure 7: A Mars Rover (<https://www.newsclick.in/Take-Bow-NASA-Perseverance-Rover-Mars>)

6. a) A DAC uses a reference voltage of 80 V and has 6-bit precision. In four successive sampling periods, each 1 sec long, the binary data contained in the output register were 100000, 011111, 011101, and 011010. (CO 2)
(PO 2)
- Construct the equation for the voltage as a function of time between sampling instants 3 and 4 using:
- i. a zero-order hold (10 Marks)
 - ii. a first-order hold. (5 Marks)
- b) Distinguish between microprocessor and microcontroller. (10 Marks)
Include in the discussion, the block diagram / schematic diagram of both. (CO 1)
(PO 1)

FORMULA SHEET

$$Ts = \frac{4}{\sigma} ; Tp = \frac{\pi}{\omega_d} = \frac{\pi}{\omega_n \sqrt{1-\zeta^2}} ; \%OS = e^{-(\zeta \omega_n / \sqrt{1-\zeta^2})} \times 100 ; \zeta = \frac{-\ln(\%OS/100)}{\sqrt{\pi^2 + \ln^2(\%OS/100)}}$$

$$\cos \theta = \zeta ; E(t) = E_o ; E(t) = E_o + \alpha t$$

$$E_o = E_{ref} \{0.5B_1 + 0.25B_2 + 0.125B_3 + \dots + (2^n)^{-1} B_n\}$$

$$\alpha = \frac{E_o - E_o(-\tau)}{\tau}$$