

PAPER NAME

**Research BOOK.docx**

---

WORD COUNT

**10626 Words**

CHARACTER COUNT

**58083 Characters**

PAGE COUNT

**52 Pages**

FILE SIZE

**2.1MB**

SUBMISSION DATE

**Oct 6, 2023 10:17 AM GMT+6**

REPORT DATE

**Oct 6, 2023 10:18 AM GMT+6**

---

**● 10% Overall Similarity**

The combined total of all matches, including overlapping sources, for each database.

- 8% Internet database
- 5% Publications database
- Crossref database
- Crossref Posted Content database
- 7% Submitted Works database

**● Excluded from Similarity Report**

- Bibliographic material
- Quoted material
- Cited material



# **REUSE OF RETURN CONCRETE SLURRY WASTE IN CONCRETE AS FINE AGGREGATE**

BY

EHATASUM BIN ALI (180051139)

MUMTAHEENA REZA (180051219)

MD. AZWAD MUTTAQI ALAM (180051227)

MD. MUSHFIQUE -US-SALEHEEN (180051234)

*A Thesis Submitted in Partial Fulfillment of The Requirements for The Degree Of*  
**BACHELOR OF SCIENCE (B.SC.) IN CIVIL AND ENVIRONMENTAL  
ENGINEERING**



**ISLAMIC UNIVERSITY OF TECHNOLOGY (IUT)- OIC**  
**DEPARTMENT OF CIVIL AND ENVIRONMENTAL ENGINEERING**  
BOARD BAZAR, GAZIPUR- 1704  
BANGLADESH.

JUNE 2023

## **Approval**

---

The thesis entitled “Reuse of Return Concrete Slurry Waste in Concrete as Fine Aggregate” submitted by Ehatasum Bin Ali, Mumtaheena Reza, Md. Azwad Muttaqi Alam and Md. Mushfique-Us-Saleheen has been acknowledged as having met the requirements in part for the Bachelor of Science in Civil and Environmental Engineering degree.

**Thesis Supervisor**

---

**Dr. Md. Tarek Uddin, PEng.**  
**Professor**  
**Structural Engineering**  
**Department of Civil and Environmental Engineering (CEE)**  
**Islamic University of Technology (IUT)- OIC**

## **Declaration**

---

It is now declared that this Thesis, as a whole, has not been submitted elsewhere for any Degree or Diploma award or accreditation.

---

**Ehatasum Bin Ali**  
**ID: 180051139**

---

**Mumtaheena Reza**  
**ID: 180051219**

---

**Md. Azwad Muttaqi Alam**  
**ID: 180051227**

---

**Md. Mushfique -Us-Saleheen**  
**ID: 180051234**

**Thesis Supervisor**

---

**Dr. Md. Tarek Uddin, PEng.**  
**Professor**  
**Structural Engineering**  
**Department of Civil and Environmental Engineering (CEE)**  
**Islamic University of Technology (IUT)- OIC**

## Dedication

---

*To our parents and teachers*

*for*

*their unwavering support and guidance.*

*Thank you for believing in us and motivating us to shape our journey.*

## Acknowledgment

---

All the praise and thanks to the all-powerful Allah, whose unending generosity has made it possible for us to complete our research. Our deepest gratitude is sent to Allah, the personification of compassion and generosity.

We would like to express our profound gratitude to Dr. Md. Tarek Uddin, Professor in the Department of Civil and Environmental Engineering at IUT, who served as our thesis supervisor. Without his knowledgeable direction, our task would not have been accomplished. We want to thank him sincerely for his helpful ideas and constant assistance throughout the process. His guidance has improved our knowledge of the subject topic and helped us overcome difficult obstacles.

We also like to express our gratitude to Mohammad Zunaied-Bin-Harun, lecturer in IUT, Department of Civil and Environmental Engineering, for his consistent assistance and helpful criticism. His contributions have improved our work's depth and quality.

Finally, we want to express our sincere gratitude to our treasured family members, close friends, and everyone who has contributed significantly to our adventure. Thanks to their joint efforts, support, and direction, we arrived here today.

## **Preamble**

---

The study aims to examine the potential impact of replacing fine aggregates and water with Recycled Concrete Slurry Waste. The strength and durability of the prepared samples were quantified and analyzed to find out the optimum replacement ratio. Comparative analysis was performed in terms of structural performance enhancement and environmental impact reduction. By assessing these properties, this study aims to contribute to the sustainable development of the construction industry and promote environmentally responsible construction practices. The forthcoming research will provide valuable insights that can inform concrete mix design, optimize resource utilization, and foster a greener and more sustainable future for the construction sector.

## Abstract

---

*A combination of leftover cement particles, cement hydration products, and fine aggregates make up return concrete slurry waste (RCSW). RCSW is a by-product generated during concrete production by ready-mix concrete plants and is generally identified as a waste material and generally disposed of as landfill material. Since environmental preservation is encouraged in the construction industries, achieving sustainable use of resources while producing concrete is becoming increasingly important. On the other hand, sand is extensively used in the construction industries as fine aggregate for making concrete which is extracted from rivers, pits, or artificially produced by crushing rocks. Therefore, this study has been planned to explore the possibility of the replacement of sand in mortar by RCSW.*

*In this study, a novel technique for successfully reusing RCSW as filler material by replacing fine aggregate in cement mortar has been investigated. Mortar specimens (50 mm by 50 mm by 50 mm) were made with the replacement of natural sand by 5%, 10%, and 10.5% with RCSW. The specimens were made with different types of cement, such as CEM Type I (linker-based cement), CEM Type II (maximum replacement of clinker by 20% with mineral admixture), 65% CEM Type I + 35% fly ash, 50% CEM Type I + 50% fly ash, 35% CEM Type I + 65% fly ash, 65% CEM Type I + 35% slag, 50% CEM Type I + 50% slag, 35% CEM Type I + 65% slag. The specimens were tested for compressive strength, water absorption, and sorptivity. The results revealed that RCSW can be used to replace a part of fine aggregate (sand) in mortar. By reusing RCSW for making mortar, the cost of mortar will be reduced, associated disposal problems will be solved, carbon dioxide emissions will be reduced, and eventually, it will help toward the sustainability of construction materials.*

**Keywords:** Return Concrete Slurry Waste (RCSW), CEM Type-I, CEM Type-II, Mortar, Blended Cement, Sorptivity, Compressive Strength.



# Table of Contents

Approval .....	ii
Declaration.....	iii
Dedication.....	iv
Acknowledgment .....	v
Preamble .....	vi
Abstract.....	vii
Chapter: 1 Introduction.....	1
1.1 Background and Motivation.....	1
1.2 Problem Statement .....	3
1.3 Purpose and Objective.....	3
1.4 Organization of the Thesis .....	4
Chapter: 2 Literature Review.....	5
2.1 Previous Studies Regarding Utilization of Slurry .....	5
2.1.1 Utilizing for Soil Stabilization .....	5
2.1.2 Sustainable Management and Utilization .....	5
2.1.3 An Impact on the Strength Properties .....	5
2.1.4 Analysis of Strength and Durability When Ceramic Slurry Is Partially Replaced 6	6
2.1.5 As Concrete Admixture .....	6
2.1.6 Marble Slurry Replacing Fine Aggregate .....	7
2.1.7 Reuse as a CO <sub>2</sub> capture medium as well as a cement paste.....	7
2.2 Studies Done in the Past Regarding the Replacement of Cement with Fly Ash and Slag 7	7
2.2.1 Experimental Investigation of Fly Ash Use in Concrete .....	7
2.2.2 Concrete Made of Fly Ash Replacing Some Portions of Cement .....	8
2.2.3 Blast Furnace Slag as Additional Cementitious Materials .....	8
2.3 Previous Studies Regarding the Comparison Between OPC and PCC.....	9
2.3.1 Compressive Strength Gain and Porosity Reduction.....	9
2.3.2 Durability Performance.....	9
Chapter: 3 Experimental Procedure & Data .....	10
3.1 Material .....	10
3.1.1 Return Concrete Slurry Waste .....	10
3.1.2 Cement .....	11
3.1.3 Fine Aggregate:.....	11

3.1.4	Slag: Blast furnace slag was used to partially replace cement.....	11
3.1.5	Fly Ash: Fly Ash was also used to partially replace cement. ....	11
3.1.6	Water: During the mixing of concrete, normal potable water was used.....	11
3.2	Specific Gravity.....	11
3.3	Water Content of RSCW.....	12
3.4	Experimental Methodology.....	12
3.5	Compressive Strength Test .....	15
3.6	Water Absorption .....	16
3.7	UPV Test.....	18
Chapter: 4	Results and Discussion .....	19
4.1	Compressive Strength Test .....	19
4.2	Absorption (Sorptivity) .....	23
4.3	UPV Test.....	27
Chapter: 5	Conclusion and Recommendations.....	28
5.1	Introduction .....	28
5.2	Conclusions .....	28
5.2.1	Compressive Strength .....	28
5.2.2	Water Absorption (Sorptivity) .....	29
5.3	Limitations of Study.....	30
5.4	Recommendations for Future Research .....	30
References.....		31
Appendices.....		34

## List of Figures

Figure 3-1: Concrete Slurry Extraction Process Schematic Diagram.....	10
Figure 3-2: RCSW from RMC Plant .....	10
Figure 3-3: Specific Gravity Test Procedure .....	11
Figure 3-4: Slurry preservation.....	12
Figure 3-5: Mortar Casting & Curing Procedure .....	14
Figure 3-6: Compressive Strength Procedure .....	16
Figure 3-7: Schematic of the Procedure.....	18

## List of Tables

Table 3-1: Specific Gravity of Materials .....	11
Table 3-2: Mortar Mixing Parameter for Preparing Cube Specimens .....	12
Table 3-3: Sample Size Calculation.....	13
Table 3-4: Mixing Proportion for OPC & PCC Samples .....	13
Table 3-5: Mixing Proportion for Slag Samples (Slag Replacing Cement) .....	14
Table 3-6: Mixing Proportion for Fly Ash samples (Fly Ash Replacing Cement).....	14

## List of Graphs

Graph 1: 28 days Strength Test Comparison .....	20
Graph 2: Strength Variation from Control Case .....	21
Graph 3: Strength Value Over 90 Days Curing .....	22
Graph 4: Strength Development Percentage over 90 days Span .....	23
Graph 5: Absorption for all CEM Type-I cases .....	24
Graph 6: Absorption for all CEM Type-II cases .....	24
Graph 7: Absorption for all Slag replacing CEM Type-I cases .....	25
Graph 8: Absorption for all Fly Ash replacing CEM Type-I cases .....	25
Graph 9: Slope Value from the Absorption vs. $\sqrt{\text{Time}}$ Graph .....	26
Graph 10: Sorptivity Coefficient Value for All Cases .....	26
Graph 11: UPV Test Data .....	27
Graph 12: Compressive Strength Data for CEM Type-I .....	34
Graph 13: Compressive Strength Data for CEM Type-II .....	35
Graph 14: Compressive Strength Data for Slag replacing 35% of CEM Type-I .....	35
Graph 15: Compressive Strength Data for Slag replacing 50% of CEM Type-I .....	36
Graph 16: Compressive Strength Data for Slag replacing 65% of CEM Type-I .....	36
Graph 17: Compressive Strength Data for Fly Ash replacing 35% of CEM Type-I .....	37
Graph 18: Compressive Strength Data for Fly Ash replacing 50% of CEM Type-I .....	37
Graph 19: Compressive Strength Data for Fly Ash replacing 65% of CEM Type-I .....	38
Graph 20: Strength Development Percentage over 90 days For CEM Type I & II cases .....	38
Graph 21: Strength Development Percentage over 90 days For Slag replacing CEM Type-I cases .....	39
Graph 22: Strength Development Percentage over 90 Days for Fly Ash Replacing CEM Type-I Cases .....	39

# Chapter: 1 Introduction

## 1.1 Background and Motivation

Environmental preservation and sustainable development are now top worldwide priorities. Concrete is becoming the second most used material resource as a result of the building industry's expansion. However, the building sector is a substantial contributor to environmental issues and the loss of natural resources in the majority of countries. The construction sector consumes over 50% of all natural resources and produces close to 50% of all waste on the planet (*De Schepper et al., 2014*). The increase in construction activity results in the daily production of construction and demolition (C&D) trash. Concrete is produced worldwide and consumed at a rate of roughly 2 tons annually per person (*Hasanbeigi et al., 2012*), resulting in significant waste generation also CO<sub>2</sub> emissions (about 5 to 8% of total man-caused CO<sub>2</sub> emissions) in 2015 (*Gordon et al., 2014*).

According to estimates, between 165 and 350 million tons of concrete waste exit the production process daily (*Iizuka et al., 2017*). In Europe, return concrete slurry waste accounts for between 1.0 and 4.0 weight percent of total production (*Correia et al., 2009*), while it accounts for between 1 to 2 weight percent in Japan (*Iizuka et al., 2012a*). In Hong Kong, the yearly production of RCSW exceeds 120,000 tons (*Xuan et al., 2016b*). For instance, in 2015, around 222.4 million tons of dehydrated RCSW may be produced given that the world produced 27.8 billion tons of concrete (*Kazaz and Ulubeyli, 2016*). The pH of RCSW will continue to rise as storage time is extended; however, a high pH (above 11.5) may have negative effects on the environment, in Japan, Spain, and Britain, it is categorized as a hazardous material that corrodes (*Iizuka et al., 2012a, Xuan et al., 2016b, Ferriz et al., 2014, Arunvivek et al., 2015, Sealey et al., 2001*).

RCSW is often disposed of in landfills (*Tam et al., 2008*), which is expensive and bad for the environment and concrete plants, respectively, because of its high alkalinity (*Xuan et al., 2016b*) and corrosion potential. Japanese researchers have examined potential neutralizing therapies, but the cost can reach \$60 per ton (*Iizuka et al., 2012a*), which is astronomically costly.

Global sand consumption has grown in part as a result of rising standards of living, population growth, and urbanization. Sand-related materials may be found in practically every house, dam, or road. In the fracking business, enormous amounts of frack sand are utilized to extract oil from shale. Sand is currently one of the most utilized natural resources, according to the United Nations Environment Program, as a result of this trend. According to UNEP research, sand and gravel makeup 85% of the total weight of minerals extracted annually across the world.

Unfortunately, increasing mining and widespread sand use threaten the ecology on a local and global scale, necessitating quick action to mitigate these consequences. Where sand is mined and gathered has different effects on the ecology. Pit sand, river sand, and sea sand are the three primary natural sand sources. Illegal sand mining and transportation practices that have been observed across the world have made the environmental effects of legal mining and sourcing worse. They occur most frequently in poorer countries.

One of the biggest problems now confronting humanity is climate change. The primary greenhouse gas emissions causing anthropogenic climate change are caused by human activity. Burning fossil fuels, industrial production methods, waste management, and changes in land use can all result in carbon emissions (*Liu et al, 2016, Z et al 2016*). One of the most polluting industries is cement: Cement manufacturing is responsible for 5% of global greenhouse gas emissions. (*Demirel et al, E et al., Eskin et al, 2017*). Because of the CO<sub>2</sub> gas emissions during the clinker manufacturing process, it is well recognized that cement manufacture contributes to the greenhouse impact (*S et al., A et al., Nta. et al., A et al., O et. l, Olorunnisola eal. al, 2016*). Concerns about the rate of economic development going beyond the Earth's carrying capacity have arisen as a result of the growing threat of catastrophic global environmental change and other examples of environmental mismanagement. Many international organizations and developed nations have advocated numerous strategies and projects to lessen these consequences, including green industrial strategy, green growth, green economy, and green structural transformation. Green transformation describes procedures used by businesses and/or sectors that have less impact on the environment (*LU et al., Y al. al., Lal. et al., 2016*). Effects on human health are the primary outcome of cement manufacture. According to the World Health Organization (WHO), non-communicable diseases account for 82 percent of all deaths worldwide. Chronic respiratory conditions including asthma and chronic obstructive pulmonary disorders among these non-communicable illnesses resulted in 4 million fatalities in 2012 or 10.7% of all fatalities. (*Gizaw et l, Z et al, Yifred et al, B et al, Tadesse et al, T et al, 2016*).

## **1.2 Problem Statement**

The problem statement of this study/thesis addresses the scope of ensuring the construction industry is more economically and environmentally sustainable. With the development of concrete technology, we can use fewer natural resources. The waste can be used in concrete instead of cement, fine aggregate, coarse aggregate, and as a further addition. Utilization of return concrete slurry waste material also results in lower costs, less energy usage, and fewer environmental dangers. So, utilizing waste products from RMC plants as building materials is the greatest way for the construction sector to evolve into more sustainable ones by using fewer natural resources such as natural sand.

Furthermore, as cement manufacturing harms the environment, this study also emphasizes minimizing cement consumption. For this, cement is largely replaced by alternate cementitious materials like fly ash and blast furnace slag.

Fly ash, a coal combustion byproduct comprised of silica, alumina, and iron, is frequently dumped in landfills. Fly ash is divided into two classes: Class C and Class F. Class C fly ash is produced by burning lignite, whereas Class F fly ash, which is dark gray and possesses cementing properties, is produced when burning bituminous coal.

Blast furnace wastes are, however, only very minimally treated as secondary raw materials. These important secondary raw materials are discarded in enormous quantities outside the factories. This scenario is untenable from an economic and environmental standpoint. Granulated blast furnace slag is one type of metallurgical slag. It involves a waste product from the iron industry. The main components are  $\text{SiO}_2$ ,  $\text{Al}_2\text{O}_3$ , and  $\text{CaO}$ ; the minor components include  $\text{MgO}$ ,  $\text{FeO}$ , and sulfides in the forms of  $\text{CaS}$ ,  $\text{MnS}$ , and  $\text{FeS}$ .

## **1.3 Purpose and Objective**

The following were the objectives of the study:

1. To investigate where the partial replacement of fine aggregates and water in the mortar with RCSW had any impact on compressive strength.
2. To investigate where the partial replacement of fine aggregates and water in the mortar with RCSW had any impact on durability.



## 1.4 Organization of the Thesis

The thesis has been grouped into five chapters.

**Chapter One** includes the background of the study, problem statement, and objectives in brief.

**Chapter Two** reviews the previous uses of RCSW and its inherent characteristics discovered in their findings. The potential scope for its reuse in this experiment has also been discussed

**Chapter Three** presents the methodology followed in this research. It includes details of the sample storage and analysis of mortar cubes in various replacement percentages. It describes in detail, the laboratory experiments that were carried out for the quantification and characterization of different qualities of the sample.

**Chapter Four** presents the numerical results that were found through these experiments. A comparative analysis was carried out in this regard to find out the optimum mix ratio. The optimum ratio considered compressive strength and durability in their criterion.

Finally, **Chapter Five** summarizes the major findings from the present study. It also presents the limitations of this study and recommendations for future studies.

## Chapter: 2 Literature Review

### 2.1 Previous Studies Regarding Utilization of Slurry

#### 2.1.1 Utilizing for soil stabilization

Stabilizing clay soils is an important engineering challenge since it has an impact on the long-term stability and operability of buildings, especially infrastructure. The current study *by Pavel Reiterman, Petr Mondschein, Barbora Douřsová, Vendula Davidová, and Martin Keppert* is concentrated on an experimental investigation of the utilization of clay soil stabilizer concrete slurry waste (CSW), which is produced during the making of ready-mix concrete. The trash under investigation is alkaline, and cement residue is present, thus there is adequate potential for the recommended use. The impact of CSW on soil stability was examined (IBI) using compressive strength, the California bearing ratio (CBR), and the Immediate bearing index. SEM was used to initially characterize the stabilization process, and then heat analysis and X-ray powder diffraction (XRD) were used to track its progress.

The study's findings demonstrated the waste material's potential as a substitute for stabilizers that are frequently employed. The development of hydrates, which is followed by the consumption of free water and a decrease in flexibility, determines the stabilizing impact. Cement has a greater kinetic of solidification, which increases the secondary effect of its application. One kilogram of the researched waste material stabilizes 380 g of OPC, saving money and the environment.

#### 2.1.2 Sustainable Management and Utilization

The goal is to encourage environmental protection in the construction sector. The importance of using resources more sustainably during the concrete production process is also growing. This research by *Md. Uzzal Hossain, Dongxing Xuan, and Chi Sun Poon* sought to ascertain how long concrete slurry waste would be environmentally sustainable (CSW). A methodology for applying CSW in the manufacture of partition wall blocks that is resource-efficient was found using life cycle assessment (LCA) approaches. In concrete batching facilities, CSW refers to the dewatered solid residues that are deposited in the sedimentation tank after washing away fresh concrete that was ordered in excess or rejected and concrete trucks. The life cycle environmental effect of the partition wall blocks, as well as their utilization of CSW as recycled aggregates or as a cementitious binder, were assessed and contrasted with the conventional approach.

Of all the production scenarios that were taken into consideration, the fabrication of eco-partition wall blocks utilizing recycled fresh concrete aggregates (CSW) had the least detrimental impact on the environment. The reuse and use of fresh CSW in the construction of eco-partition wall blocks was the most sustainable approach, according to the LCA's evaluation of environmental performance. Due to the use of CO<sub>2</sub> curing to produce carbonated partition wall blocks utilizing CSW and FRCAs, the carbon emissions may be considered to be carbon neutral.

#### 2.1.3 An Impact on the Strength Properties

The reuse of construction and demolition waste in traditional construction is the main topic of this study conducted by *Bhavsar Jaykumar K. and Patva Vivek*. In this study, recycled coarse and fine aggregate are used instead of natural materials. Records show that using them greatly

diminishes the strength attribute. This happened as a result of the recycled aggregates' decreased quality. The goal of this study is to improve the recycled aggregate's quality. Recycled aggregates (RA) are subjected to a cement slurry treatment procedure before being blended with fine recycled aggregates (FRA). In this study, recycled aggregate replaces natural aggregate by 10, 20, and 30%, respectively. Use Natural Aggregates (NA) in place of PRA 10, 20, and 30%. Also, evaluate workability by combining the PRA and FRA proportions.

As the fraction of R.A. grew, the comparability of NAC, RAC, and PRAC slump values reduced. When F.R.A. was used, the compaction factor's value remained constant, but when PRA to F.A. ratio grew, it started to match the value of NAC. Recycled aggregates that have been processed have greater compressive and tensile strengths than unprocessed aggregates. Compressive and tensile strength increased by 28 to 45 percent, which enhanced flexural strength characteristics.

#### ***2.1.4 Analysis of Strength and Durability When Ceramic Slurry Is Partially Replaced***

The two categories of ceramic waste that are most often generated by the ceramics industry are hard waste and insect trash. Pest waste is a byproduct of cleaning and finishing ceramic tiles. It is also known as filter waste or slurry trash. The study *by Lalji Prajapati, I. N. Patel, and V.V. Agrawal* examines the use of leftover ceramic slurry powder in concrete instead of cement. M25 concrete was created by using a ceramic slurry waste powder that has been filtered through 90 microns in place of 0% to 30% of Ordinary Portland 53-grade cement. The water-cement ratio of 0.48 is used to calculate the compressive strength, flexural strength, water absorption, and sorptivity of a material. According to the results, using ceramic waste powder instead of steel can increase core compressive strength by up to 30% without appreciably altering M25's typical strength.

The characteristic strength of this concrete is lower than regular concrete when the ceramic waste powder is added. Because of its height-to-diameter ratio, a cylinder's compressive strength is closest to a cube's. Therefore, up to 30% of the ceramic waste powder has been replaced without impacting the concrete's typical M25 grade strength. Flexural strength is closest to normal concrete when compared to that material. However, when the ceramic waste powder was replaced, its strength barely changed. In comparison to normal concrete, water absorption, and sorptivity rose when cement was replaced; however, after a 10% interval, this rise became extremely little.

#### ***2.1.5 As Concrete Admixture***

This particular study by *Zhanhua Chen, Guangxing Lai, Yunhui Fang, Xinfu Zhang, and Yuanqiang Guo*, it was looked at whether cement slurry may be used as a concrete additive. Waste cement slurry was examined for its chemical makeup, particle size distribution, and concrete testing outcomes. The findings imply that adding a suitable dose of WS-1 has no impact. It enhances the workability of concrete while having a substantial influence on its strength. According to the paper, WS-1 can be added to concrete to make it more workable.

In WS-1, CaO concentrations are very low whereas SiO<sub>2</sub> and Al<sub>2</sub>O<sub>3</sub> concentrations are rather high. Scanning electron microscopy revealed that the bulk of the WS 1 particles were big, with small numbers of spherical and white irregular particles. The average particle diameter of the pressure filter slurry is 10.233 m, and the majority of the particle sizes fall between 0 and 32 meters. 10% is the recommended amount of WS 1 to mix into concrete, which can make it

more workable while somewhat weakening it. WS 1 offers similar advantages to mineral powder and fly ash when it comes to improving the workability of concrete, and its strength is about identical to that of the same quantity of both.

### **2.1.6 Marble Slurry Replacing Fine Aggregate**

Since only 30% of the primary product is recovered from the waste generated during the manufacture of marble, waste, and waste management practices account for the majority of irreparable rubbish. Dumping sites have a dirty look to them. Both rivers and other bodies of water and the top layer of fertile soil are polluted. The supplies for irrigation and drinking water, the air, the vegetation, and the animals are all in danger.

Bulk usage is the best remedy for marble slurry contamination. The building industry is the only one that can employ marble slurry on such a large scale. Different marble slurry qualities were identified in the lab. Fineness modulus was found to be 0.91, sp. gravity was found to be 2.61, and marble slurry was found to be 30% more effective than sand in cement concrete.

According to the findings of the practical study *by Raj.p.singh Kushwah, Prof (Dr.) Ishwar Chand Sharma, and Prof. (Dr.) PBL Chaurasia*, adding marble slurry to cement mortar and cement concrete both results in a good and acceptable strength (replacing sand). It exhibits the same strength as the control and may replace sand up to 30% in filler applications.

### **2.1.7 Reuse as a CO<sub>2</sub> capture medium as well as a cement paste**

Concrete slurry waste (CSW), a dangerous caustic material, is produced by ready-mixed concrete manufacturers as they produce concrete. If disposed of in landfills, its high pH value, heavy metal pollution, and accumulation would impact the ecosystems and surroundings. In this study by *Dongxing Xuan, Baojian Zhan, Chi Sun Poon, and Wei Zheng*, a unique technique for successfully recycling CSW in new construction materials was devised. This procedure comprised the use of a cementitious paste and fresh, calcium-silicate-rich CSW as a CO<sub>2</sub> collecting medium. The experimental results showed that the collected CSWs had a pH range of 12.5 to 13.0 when held for 28 days, with a significant pH reduction after that.

Due to hydration products, CSWs possessed high concentrations of CaO and SiO<sub>2</sub>, a pH range of 12.5 to 13.0, a water-to-solid ratio of 0.76 to 1.12, a quick development of compressive strength, a reduction in drying shrinkage of 50%, and a CO<sub>2</sub> uptake range of 3.35 to 3.90 percent by mass.

## **2.2 Studies Done in the Past Regarding the Replacement of Cement with Fly Ash and Slag**

### **2.2.1 Experimental Investigation of Fly Ash Use in Concrete**

Cement replacement is becoming more and more significant. The quality of the fly ash was enhanced through the fly ash operations and collection systems. To evaluate the use of fly ash in concrete, part of the cement is replaced with fly ash. In this experiment by *Khushal Chandra Kesharwani1, Amit Kumar Biswas, Anesh Chaurasiya1, and Ahsan Rabbani*, different amounts of fly ash—including 0%, 25%, 50%, 75%, and 100%—were added to the concrete mixture. The effects of fly ash on workability, setting time, compressive strength, and water content are studied. Experiments on various concrete mixes were carried out to see how the properties of concrete would change if fly ash were used in place of part of the cement.

Due to its ability to lower cost, CO<sub>2</sub> emissions, cement content, and cementitious characteristics, fly ash is a crucial component of sustainable concrete. Additionally, it improves cementitious qualities and natural resource preservation. High-volume fly ash concrete, which minimizes environmental effects and conforms with economic effectiveness and ecological behavior, offers a solution to the problem of producing sustainable concrete in the future.

### ***2.2.2 Concrete Made of Fly Ash Replacing Some Portions of Cement***

Fly ash is a byproduct of the coal industry that is readily available around the world. Fly ash is increasingly used nowadays as a partial replacement for cement in concrete, principally due to concrete's enhanced long-term durability and favorable environmental effects. Whether fly ash is utilized as a cementation component in concrete depends on several factors, including design strength, water demand, and fly ash's cost relative to cement. This study by [Wrida O. ALasefir](#) uses experiments to explore the impact of fly ash on the development of concrete strength and the optimum approach to using fly ash in concrete. The concrete grade M15 was chosen and designed using the IS 456-2000 Standard methodology. The cement was replaced.

By lowering the amount of cement and heat of hydration in a concrete mix, fly ash enhances the workability of concrete. It also promotes resource efficiency and decreases environmental effects. Additionally, it makes concrete mixes more cost-effective and ecologically friendly by lowering the amount of cement and heat of hydration in the mixture.

### ***2.2.3 Blast Furnace Slag as Additional Cementitious Materials***

Supplementary cementitious materials (SCMs) are substances that help make cement. Hydraulic or pozzolanic procedures were used to toughen the concrete's characteristics. In SMCs, GGBFS, often referred to as ground granulated blast furnace slag, can occasionally be utilized in place of cementitious materials. The benefits of concrete components include both cost and performance improvements. However, because GGBFS is not generally known in Indonesia, there is currently no study on this product. The efficacy of concrete containing GGBFS as a partial replacement for cement was investigated in this study by [R A T Cahyani I, Y Rusdianto](#), with GGBFS weight percentages ranging from 0% to 30%, 50%, and 70% of cement weight. Concrete's elastic modulus and compressive strength are being studied as mechanical qualities. To determine how long concrete will survive, porosity is tested.

It was shown that GGBFS may replace up to 50% of a concrete mix's cement weight without reducing the concrete's compressive strength. Since concrete has a lower compressive strength when young, using it with GGBFS is more suitable when significant initial strength is not required. Since GGBFS concrete would develop its strength more gradually than regular concrete, the strength may not be entirely realized by 28 days. The addition of GGBFS to the concrete mixture may enhance the cement paste's fluidity, making the concrete easier to work with. Concrete's durability is increased by partially replacing cement with GGBFS. More GGBFS will decrease the number of pores in concrete.

## 2.3 Previous Studies Regarding the Comparison Between OPC and PCC

### 2.3.1 Compressive Strength Gain and Porosity Reduction

Concrete's compressive strength and durability are both impacted by porosity. This study by [M. L. R. Siddique; M. Joarder; R. M. Shihab and Z. I. Zahid](#) compares the porosity and strength of Portland Composite Cement (PCC) and Ordinary Portland Cement (OPC) over time. This study aims to investigate the relationship between porosity and the compressive strength of OPC and PCC mortars. The porosity test has cure periods of 4, 7, 10, 14, 21, and 28 days. For the compressive strength test, the curing days for the cement mortar samples were 3, 7, 14, 28, 42, and 56 days. Portland cement CEM-I, 52.5 N, and CEM-II, 42.5 N, were utilized as the OPC and PCC in this experiment, respectively. Increases in OPC cement were discovered to happen at a young age.

This research has ultimately led to the conclusion that for specific types of cement, such as OPC or PCC cement, strength in the OD state is always greater than in SSD condition. Due to the variance in compressive strength from the SSD condition standard, compressive strength in OD conditions is not a measurement that is considered to be a standard. OPC cement has more strength when it is younger, whereas PCC cement gains greater strength as it ages, specifically after 28 days. Porosity is a significant issue for this study. The results of this experiment showed that cement mortar porosity reduces as cement mortar ages. The compressive strength of cement mortar increases as porosity decreases.

### 2.3.2 Durability Performance

Concrete is the most used building material in Bangladesh. Due to the extended design lives that concrete projects frequently have, relying solely on compressive strength to assess concrete quality might have disastrous consequences in the future. A comparative study by [R. Rumman, M.R. Kamal, T. Manzur, and M.A. Noor](#) regarding the strength and durability characteristics of locally-made cement is crucial given the dearth of published research in this field. Ordinary Portland Cement (CEM I) and Portland Composite Cement (CEM II) are the two types of cement produced locally in Bangladesh; with CEM I being used more frequently. On the other hand, it is hoped that CEM II concrete would be more durable and contain less clinker, reducing CO<sub>2</sub> emissions during manufacture. The Rapid Chloride Permeability Test (RCPT) was performed on concrete.

In comparison to CEM I cement, this study indicated that locally made CEM II cement in Bangladesh may generate concretes with greater durability. However, further research needs to be done using a bigger sample size and the many CEM II brands that are sold in the nation. It is possible to increase the use of CEM II cement throughout the nation, reducing carbon emissions and offering a more sustainable method of producing cement. It is less expensive and better for the environment.

## Chapter: 3 Experimental Procedure & Data

### 3.1 Material

#### 3.1.1 Return Concrete Slurry Waste

RCSW was obtained from the ready-mixed concrete batching plants' reclamation system, which involved washing off excess or rejected new concrete to recover the coarse aggregates and washing concrete mixer trucks. Then fresh concrete was accumulated from the sedimentation pond.

There were five sections in the sedimentation ponds:

1. **Reception box**, which controls water flow after receiving water from a concrete batching plant. In this box, wastewater and extra fresh concrete are also released.
2. **A segregation container** for collecting oil from cleaning the concrete manufacturing facility.
3. **A residual segregation box** that divides the water to keep CSW in place.
4. To allow only water to reach the **final box**, which accumulates and reclaims water, a security box holds all other items that eluded from the previous boxes.

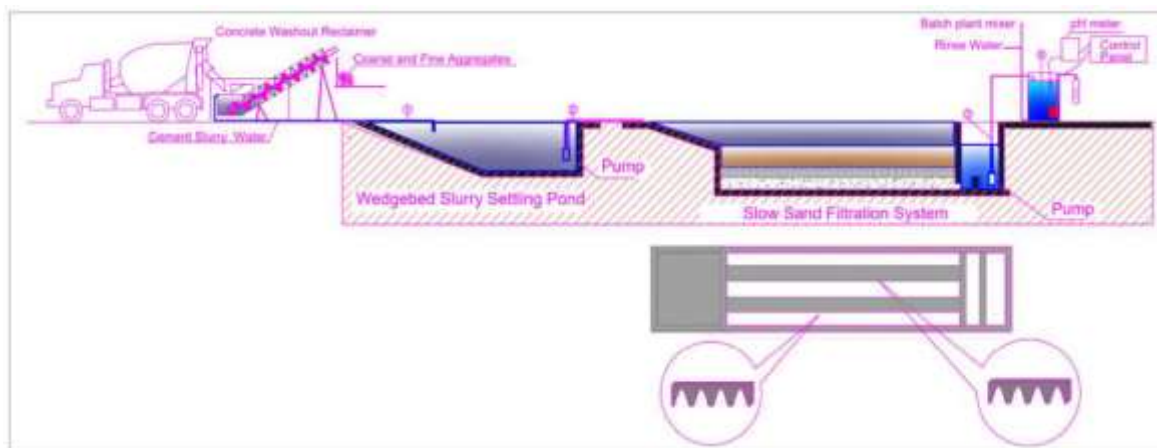

Figure 3-1: Concrete Slurry Extraction Process Schematic Diagram

Source: Ghrair, A. M., Heath, A., Paine, K., & Kronz, M. Al. (2020). Waste wash-water recycling in ready-mix concrete plants. *Environments - MDPI*, 7(12), 1–15.

<https://doi.org/10.3390/environments7120108>



Figure 3-2: RCSW from RMC Plant

Clarified water was then recycled to create RCSW using a concrete sandstone separation and filtration process.

### 3.1.2 Cement

In our research, we used two cement types to better understand and compare the mortar properties in two different cases.

- i. CEM Type- I (Ordinary Portland Cement, OPC)
- ii. CEM Type- II (Portland Composite Cement, PCC)

### 3.1.3 Fine Aggregate:

Used river sand that is easily accessible locally and its fineness modulus was 1.75 as we used 75% of the total sand retained from the 300 mm and 25% retained from the 150 mm sieve.

**3.1.4 Slag:** Blast furnace slag was used to partially replace cement.

**3.1.5 Fly Ash:** Fly Ash was also used to partially replace cement.

**3.1.6 Water:** During the mixing of concrete, normal potable water was used.

## 3.2 Specific Gravity

According to **ASTM D792**, the specific gravity of each material was measured. Kerosene was used instead of water for the procedure as it is more inert than water to react with any particles present in the materials that were used. But first, the specific gravity of kerosene was measured as 0.85 since this value was required to multiply with the specific gravity values for correction due to using kerosene. Finally obtained values are described below:

Table 3-1: Specific Gravity of Materials

Materials	Specific Gravity
RCSW	2.31
Sand	2.58
CEM Type- I	3.15
CEM Type- II	2.9
Slag	2.16
Fly Ash	2.12



Figure 3-3: Specific Gravity Test Procedure



### 3.3 Water Content of RSCW

According to ASTM D6980, the water content of the RSCW specimen was measured as 72% by taking raw specimen weight and weight after oven drying for 24 hours. RCSW was kept in a closed container and away from sunlight to preserve the existing water content regularly water content was measured to check whether the water content was stable or not.



Figure 3-4: Slurry preservation

### 3.4 Experimental Methodology

Table 3-2: Mortar Mixing Parameter for Preparing Cube Specimens

<b>Mixing parameters (Mortar)</b>	
<b>Cement Type:</b>	
CEM type I (OPC) CEM type II (PCC) CEM type I (65%) + Slag (35%) CEM type I (50%) + Slag (50%) CEM type I (35%) + Slag (65%) CEM type I (65%) + Fly Ash (35%) CEM type I (50%) + Fly Ash (50%) CEM type I (35%) + Fly Ash (65%)	
<b>w/c ratio:</b>	0.5
<b>s/c ratio:</b>	2.00
<b>Slurry Content:</b> <input type="checkbox"/> 0% <input type="checkbox"/> 5% <input type="checkbox"/> 10% <input type="checkbox"/> 10.5%	
<b>Total cases:</b>	26

Table 3-3: Sample Size Calculation

Sample number for mortar specimens		
Curing period	Compressive strength (ASTM C 109)	Sorptivity (ASTM C 1585)
3 days	3	
7 days	3	
14 days	3	
28 days	3	3
56 days	3	
90 days	3	
Total	18	3
Total mortar cubes (50mm x 50mm x 50mm) per case = 21		
Total number of cubes = 26 x 21 = 546		

Table 3-4: Mixing Proportion for OPC & PCC Samples

Case Identification	Types of Cement	w/c	s/c	Slurry (%)	Weights (kg)			
					Cement	Water	Sand	Slurry
OPC- 0%	CEM type- I	0.5	2	0%	2.277	1.139	4.554	0
OPC- 5%				0.616		4.327	0.726	
OPC-10%				0.088		4.097	1.46	
OPC- 10.5%				0.04		4.076	1.526	
PCC- 0%	CEM type- II	0.5	2	0%	2.238	1.119	4.476	0
PCC- 5%				0.602		4.252	0.718	
PCC-10%				0.085		4.027	1.436	
PCC- 10.5%				0.038		4.007	1.502	

Table 3-5: Mixing Proportion for Slag Samples (Slag Replacing Cement)

Case Identification	Type of Cement	w/c	s/c	Slurry (%)	Weights (kg)				
					Cement	Slag	Water	Sand	Slurry
Slag (35%)-0%	CEM type- I (65%) + Slag (35%)	0.5	2	0%	1.48	0.544	1.139	4.554	0
Slag (35%)-5%				0.616			4.327	0.726	
Slag (35%)-10.5%				0.04			4.076	1.526	
Slag (50%)-0%	CEM type- I (50%) + Slag (50%)	0.5	2	0%	1.139	0.778	1.139	4.554	0
Slag (50%)-5%				0.616			4.327	0.726	
Slag (50%)-10.5%				0.04			4.076	1.526	
Slag (65%)-0%	CEM type- I (35%) + Slag (65%)	0.5	2	0%	0.797	1.013	1.139	4.554	0
Slag (65%)-5%				0.616			4.327	0.726	
Slag (65%)-10.5%				0.04			4.076	1.526	

Table 3-6: Mixing Proportion for Fly Ash samples (Fly Ash Replacing Cement)



Figure 3-5: Mortar Casting & Curing Procedure

Case Identification	Type of Cement	w/c	s/c	Slurry (%)	Weights (kg)				
					Cement	Fly Ash	Water	Sand	Slurry
Fly Ash (35%)- 0%	CEM type- I (65%) + Fly Ash (35%)	0.5	2	0%	1.48	0.544	1.139	4.554	0
Fly Ash (35%)- 5%				5%			0.616	4.327	0.726
Fly Ash (35%)- 10.5%				10.5%			0.04	4.076	1.526
Fly Ash (50%)- 0%	CEM type- I (50%) + Fly Ash (50%)	0.5	2	0%	1.139	0.778	1.139	4.554	0
Fly Ash (50%)- 5%				5%			0.616	4.327	0.726
Fly Ash (50%)- 10.5%				10.5%			0.04	4.076	1.526
Fly Ash (65%)- 0%	CEM type- I (35%) + Fly Ash (65%)	0.5	2	0%	0.797	1.013	1.139	4.554	0
Fly Ash (65%)- 5%				5%			0.616	4.327	0.726
Fly Ash (65%)- 10.5%				10.5%			0.04	4.076	1.526

### 3.5 Compressive Strength Test

Compressive strength test was done on the 3<sup>rd</sup> day, 7<sup>th</sup> day, 14<sup>th</sup> day, 28<sup>th</sup> day, 56<sup>th</sup> day, and 90<sup>th</sup> day respectively. It was carried out on the compressive testing apparatus. Continuous loading was applied to the cubes after they had been arranged as in the image.



*Figure 3-6: Compressive Strength Procedure*

The machine ceased applying load automatically when the first crack was noticed. Following the recording of the reading, the cube compressive stress was calculated using the equation Load/Area.

### **3.6 Water Absorption**

This test method can be used to calculate the increase in mass of a specimen as a function of time when just one surface of the specimen is exposed to water to measure the rate of water absorption (sorptivity) by hydraulic cement concrete. The specimen is conditioned to maintain

a constant moisture state in the capillary pore system in an environment with a specified relative humidity. Unsaturated concrete first forms capillary suction when it comes into touch with water and the exposed surface of the specimen is submerged in water.

The goal of this technique is to ascertain how susceptible unsaturated concrete is to water infiltration. Concrete absorbs water at a rate that is generally different from the pace at which a sample obtained from the interior absorbs water.

The outside surface frequently receives less curing than desired and is subjected to the most dangerous environmental factors.

This kind of testing is used to determine how quickly interior and exterior concrete absorbs water. Absorption measurements may be made at various distances from the exposed surface by drilling a core and cutting it transversely at predetermined depths. You can drill the core horizontally or vertically.

The amount of water that permeates through a concrete surface is influenced by a variety of variables, such as the following:

- the proportions of the mortar mixture;
- the presence of chemical admixtures and supplementary cementitious materials;
- the composition and physical characteristics of the cementitious component and the aggregates;
- the amount of entrained air;
- the type and duration of curing;
- the degree of hydration or age;

The mortar's moisture level at the time of testing has a significant impact on water absorption as well.

The change in mass divided by the intersection of the test specimen's cross-sectional area and the density of water yields the absorption,  $I$ . The density of water is tested using a value of 0.001 g/mm<sup>3</sup>, disregarding the temperature dependency of the density.  $I$  is then measured in millimeters.

$$I = m_t / (a * d),$$

where:

$m_t$  = the change in specimen mass in grams at time  $t$ ; and

$a$  = the exposed area of the specimen in mm<sup>2</sup>; and

$d$  = the density of the water in g/mm<sup>3</sup>;

The slope of the line that fits the data the best when  $I$  plotted it against the square root of time ( $s^{1/2}$ ) gives us the initial rate of water absorption (mm/s<sup>1/2</sup>). Use least squares, linear regression analysis, and the plot of  $I$  vs. time<sup>1/2</sup> to get this slope. Use all of the points between 1 and 6 hours for the regression analysis, but leave out points for moments when the slope of the plot has changed. The initial rate of absorption cannot be calculated if the data between 1 min and 6 h do not exhibit a consistent curvature and do not follow a linear connection (a correlation coefficient of less than 0.98).

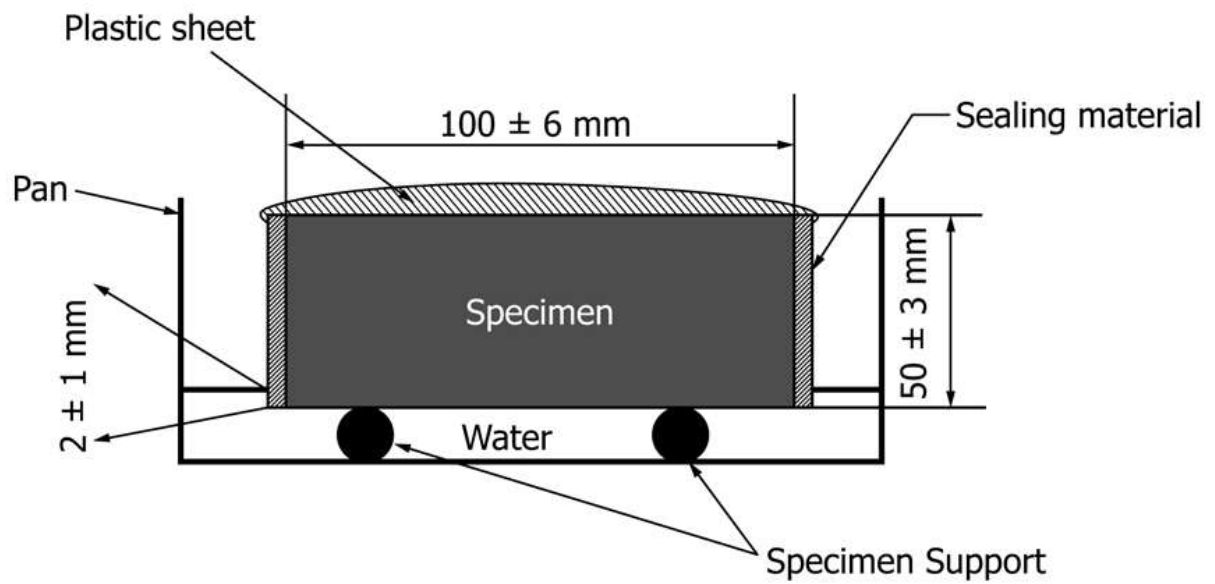

Figure 3-7: Schematic of the Procedure

### 3.7 UPV Test

The UPV (Ultrasonic Pulse Velocity) tests are used to evaluate a material's integrity, describe it, and assess other physical characteristics that affect wave propagation. According to **ASTM E 114-95**, they are a helpful technique for quality control and may be used for the material characterization of concrete, thickness measurement, and fault identification.

Once it is feasible to examine the homogeneity of the material, UPV techniques are one of the most promising ones for evaluating concrete constructions.

Utilizing how a structure's attributes change over time allows for complete control over the structure. It is possible to assess the structural integrity or locate heterogeneous areas by analyzing differences in ultrasonic velocity wave propagation. The foundation of the ultrasonic testing procedure for concrete is the idea that the propagation time indicates the material's density, which may be connected to mechanical characteristics like compressive strength and elasticity module.

The tests can also be used to look into the connection between concrete properties and compressive strength. Investigating the connection between material density and compressive strength and how it impacts ultrasonic velocity waves is the basic idea.

The connection is not always trustworthy when various factors, such as the water/cement ratio, the size and type of aggregate, the molding process, the specimen size, and the cement type, affect the concrete strength. Utilizing UPV techniques, the homogeneity of the concrete used in construction may also be evaluated. Although the use of UPV for concrete assessment is justified by the link between it and concrete density, it's vital to be aware of its limitations.

The primary factor that directly affects concrete strength is the w/c ratio. The definition of the pore structure and the material compacity are both significantly influenced by the cement-to-aggregate ratio. In this study, w/c ratios of 0.50 for various replacement instances were examined.

Given the advancement of cement hydration, the cure duration is a factor that is quite important to concrete strength. The UPV was tested in cubic specimens after 28 days to see how responsive it was to these changes. After the UPV test was conducted, the specimens were put through a strength test.

The experimental study relied on the use of two distinct types of cement (CEM Type I and II), as well as RCSW and two different proportions of sand as fine aggregate. The goal is to determine if the changes in these materials' compatibility and affinity with the cement matrix would result in appreciable variances in the UPV results.

The concrete curing type was a further research variable. The strength, permeability, and surface porosity can all be impacted by this factor. Cubic specimens were placed in a submerged environment to cure.

## **Chapter: 4      Results and Discussion**

### **4.1 Compressive Strength Test**

The data for each case's compressive strength after 28 days of curing in the submerged condition are displayed in the accompanying graph. According to the graph, the maximum strength value was for OPC-10.5%, and the lowest value was for the instance where Fly Ash replaced 65% of the cementitious material and no RCSW was used as the fine aggregate instead of sand which is Fly Ash 65%- 0%. The CEM Type-I (OPC) cases had the best overall



performance of any case. The lowest strength values were seen in situations when Fly Ash was used to replace CEM type-I in part.

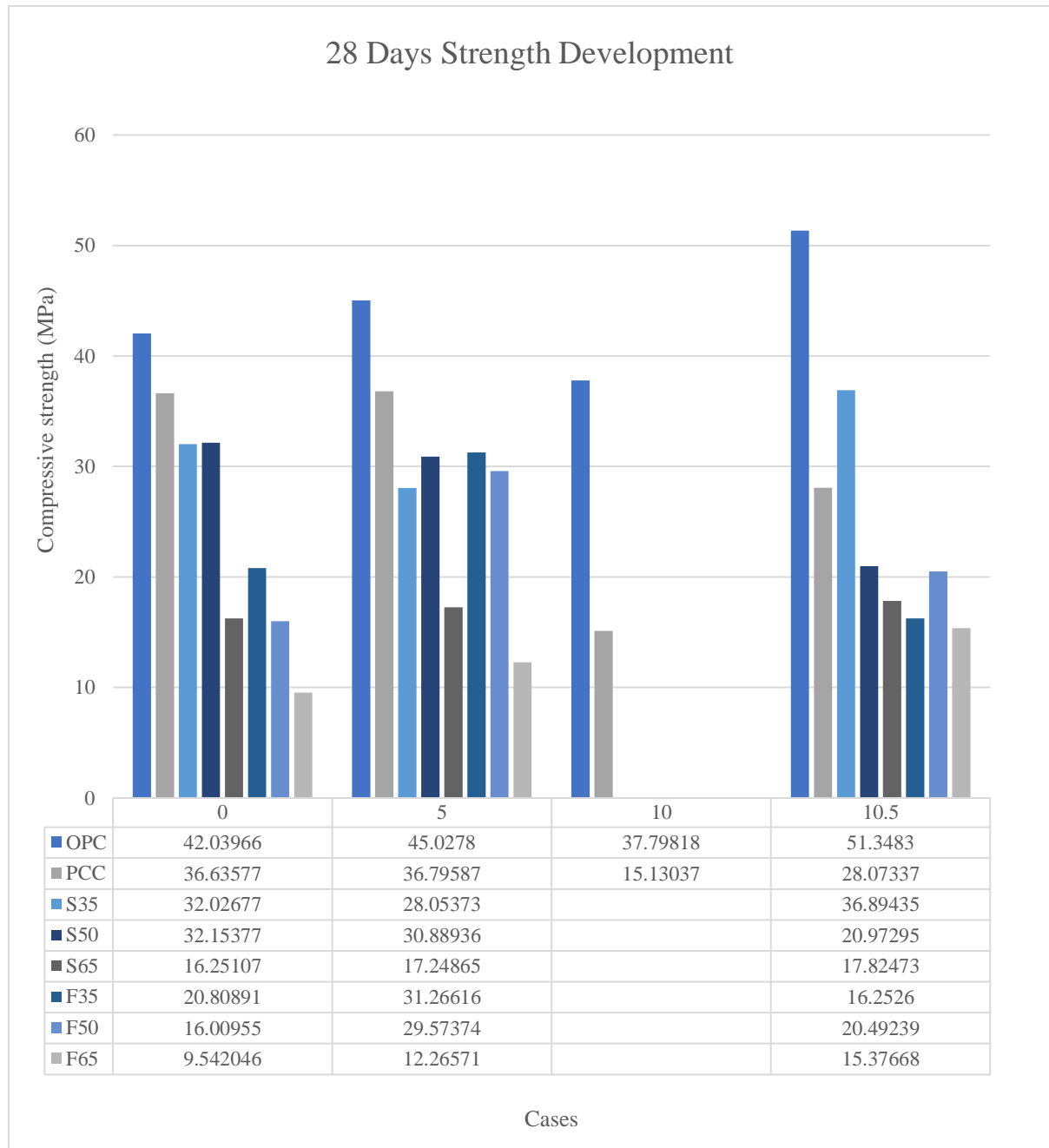

Graph 1: 28 days Strength Test Comparison

The following graph compares the strength variation of instances with RCSW replacement rates of 5% and 10.5% to the control case of OPC- 0%. Only OPC- 5% and OPC- 10.5% were able to boost their strength in comparison to the optimal case after the data were analyzed; all other instances tended to decrease. Fly Ash cases, which made up 65% of replacing the CEM Type-I, exhibited the biggest decline.

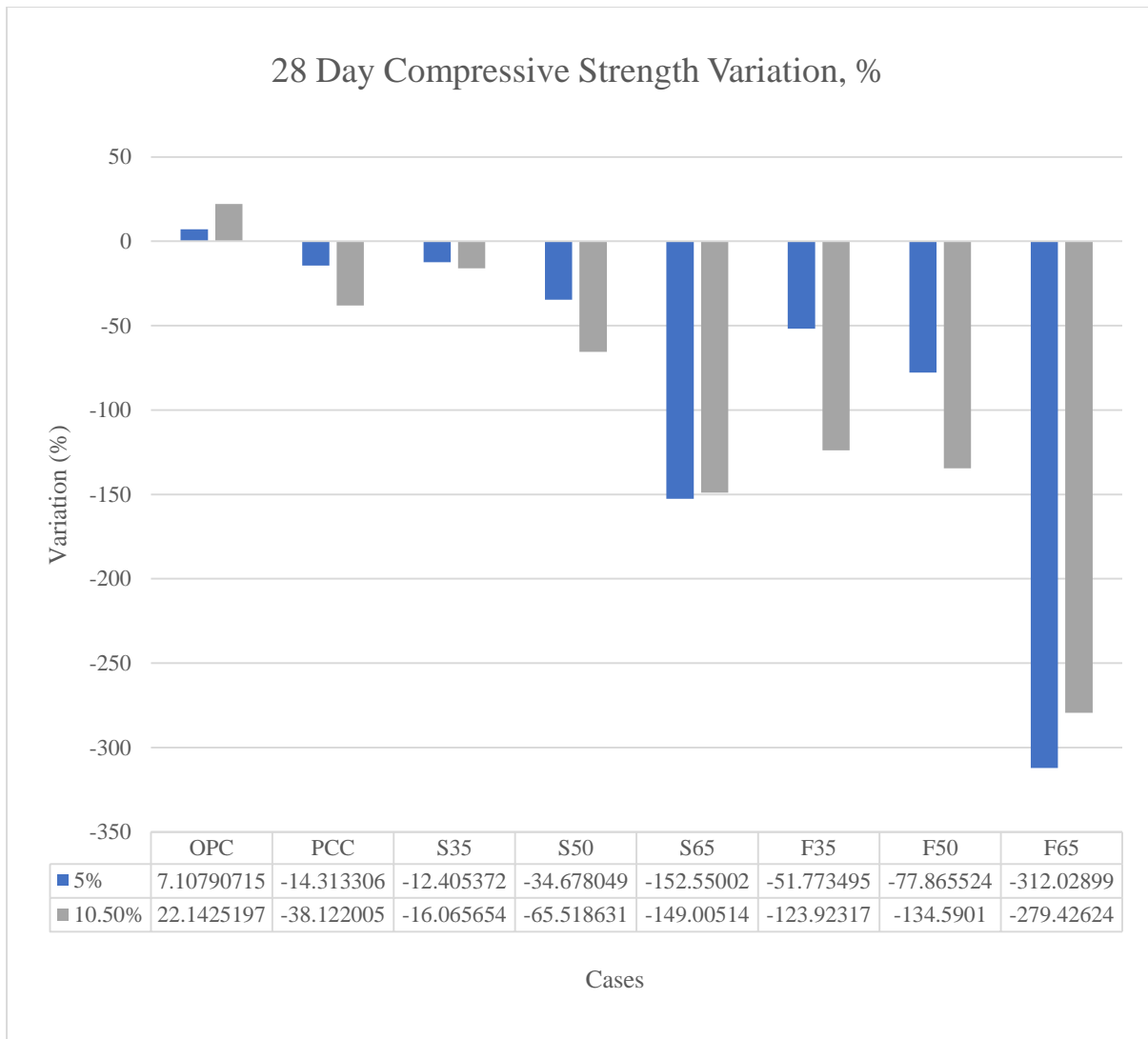

Graph 2: Strength Variation from Control Case

One example from each variation had a stronger strength value when all the cases employing different cementitious components were analyzed, compared to other RCSW replacement proportions. These examples are shown below along with their strength values. As was previously observed, Fly Ash 50-5% has the lowest strength value out of all four examples, whereas OPC-10.5% has the highest. The OPC-10.5% instance exhibited a statistically

significant increase from 56 to 90 days. The PCC-5% line resembles an irregular pattern as strength grew up to 90 days. Slag 35-10.5% displayed a parabolic curve up to 56 days when the value of the 90-day strength test slightly increased. Fly Ash 50-5% displayed almost a straight line but failed to maintain the tendency since the value of the 90-day strength test didn't follow the trend.

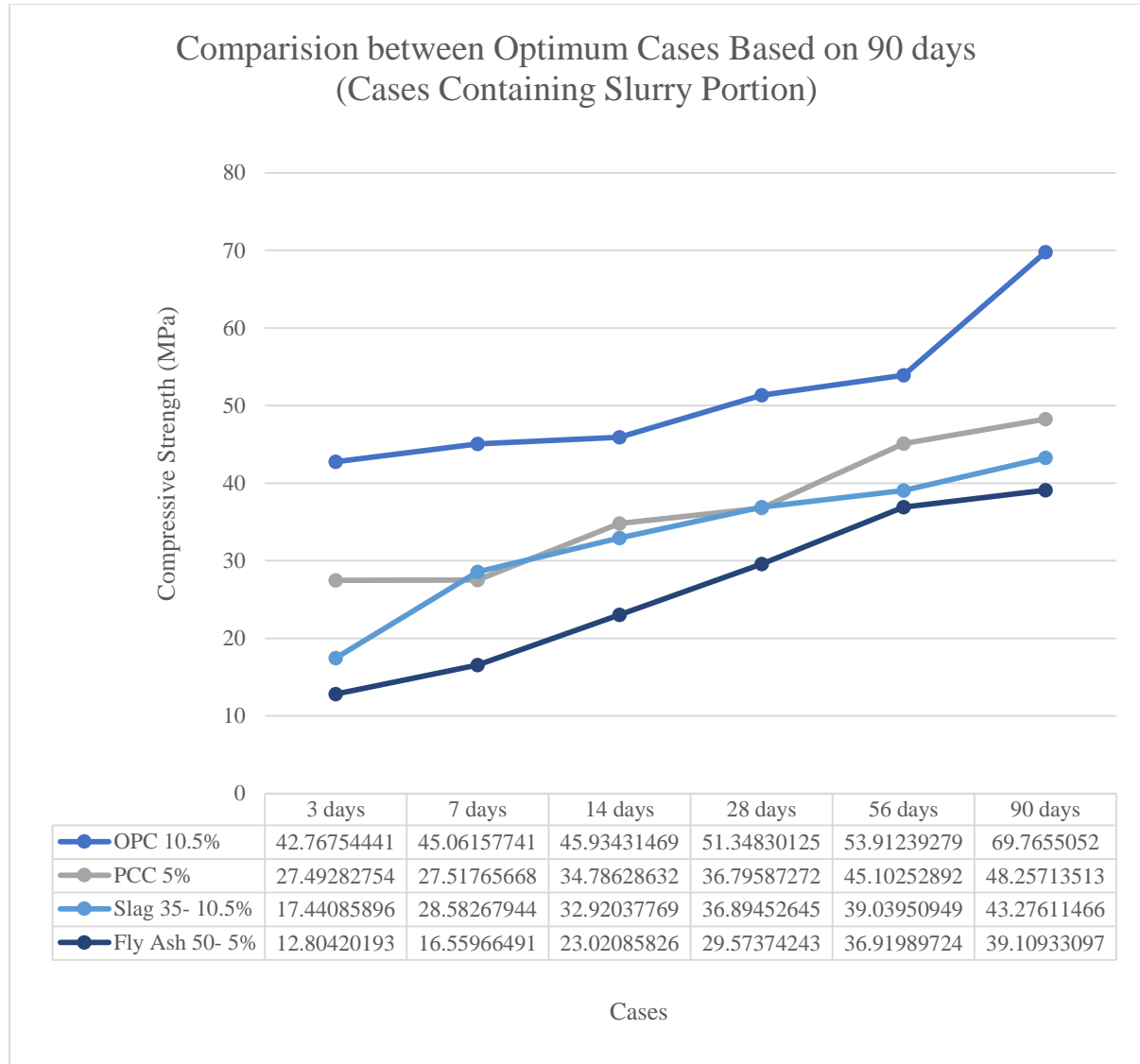

Graph 3: Strength Value Over 90 Days Curing

The graph that follows shows the percentage of strength development for the instances that demonstrated the best strength values for each cementitious component after 3, 7, 14, 28, 56, and 90 days. The Fly Ash 50-5% case obtained the least strength of the four, whereas the OPC-10.5% case gained the majority of its strength within three days of curing. After 14 days, Slag

35 gained 10.5% more strength than PCC, which grew 5% more. Fly Ash developed the highest strength overall after 28 days, gaining 50–5%, and the same is true for the strength gains after 28 days and 56 days. However, during the 56 and 90-day intervals, OPC- 10.5% significantly increased in strength. Based on the analysis of these data, Fly Ash strength gains of 50–5% were evenly dispersed over covers. When it comes to OPC-10.5%, the majority of the strength growth took place during the periods of 0 to 3 days and 56 to 90 days. Other periods couldn't significantly increase the proportion.

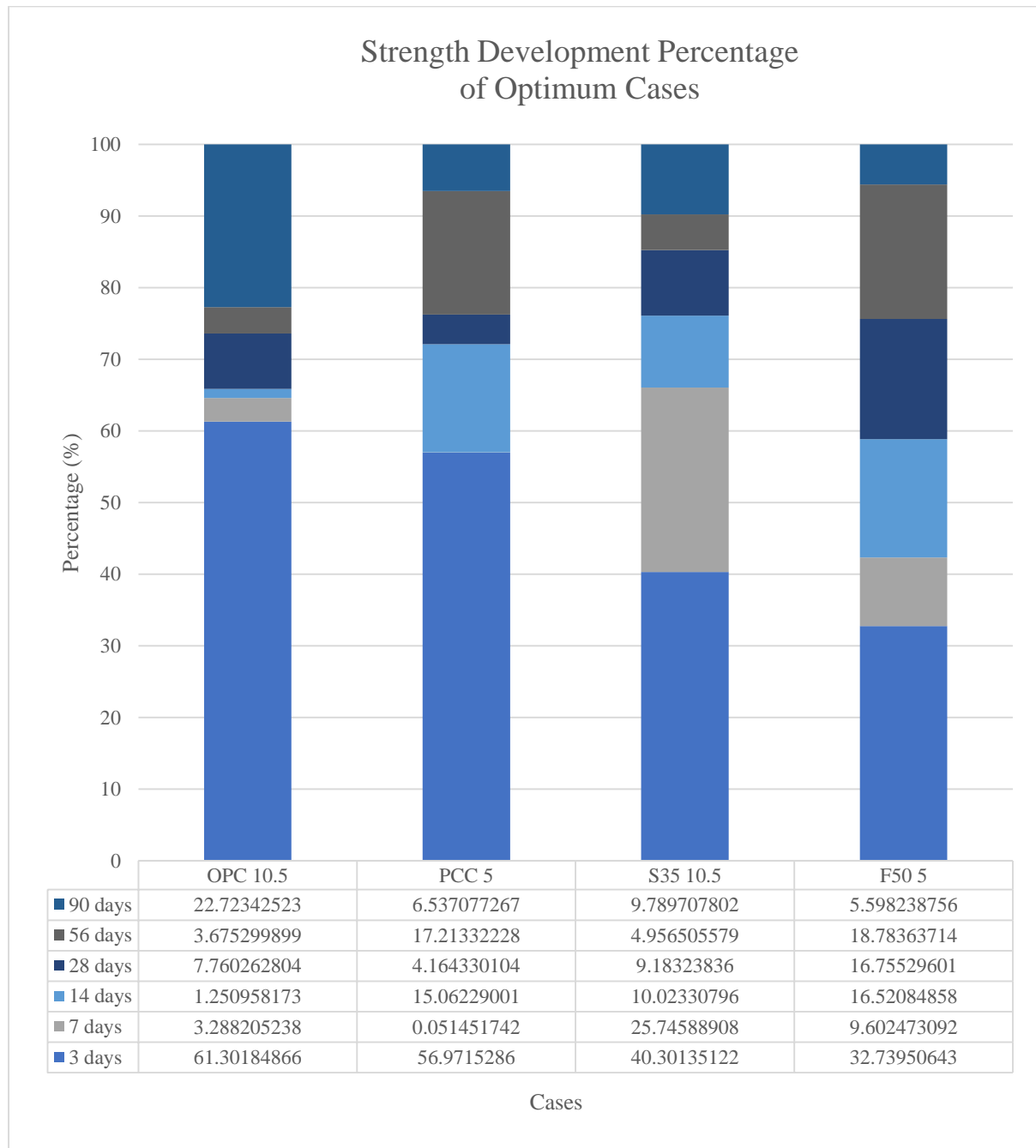

Graph 4: Strength Development Percentage over 90 days Span

## 4.2 Absorption (Sorptivity)

The following graphs illustrate changes in absorption and I (mm) values for each cementitious component over time. For all sand replacement situations using RCSW, those involving slag

and fly ash displayed nearly identical results. However, OPC 10% casein CEM Type-I patients exhibited better absorption value than the others and PCC 10.5% casein CEM Type-II cases.

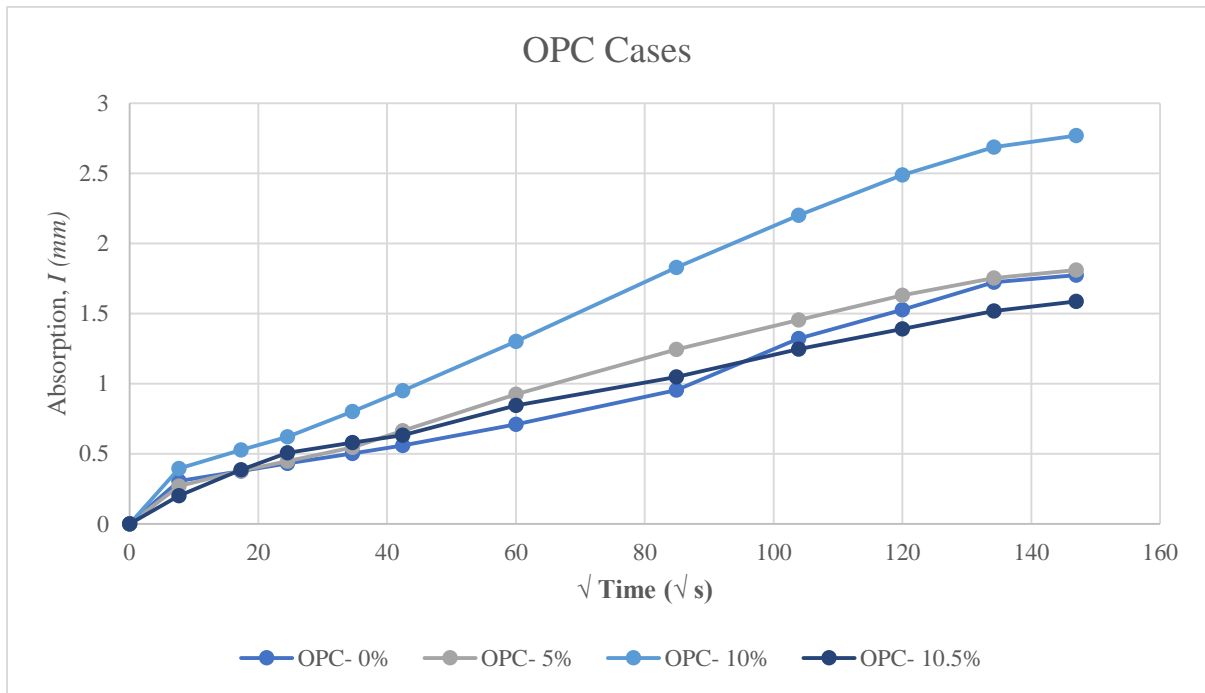

Graph 5: Absorption for all CEM Type-I cases

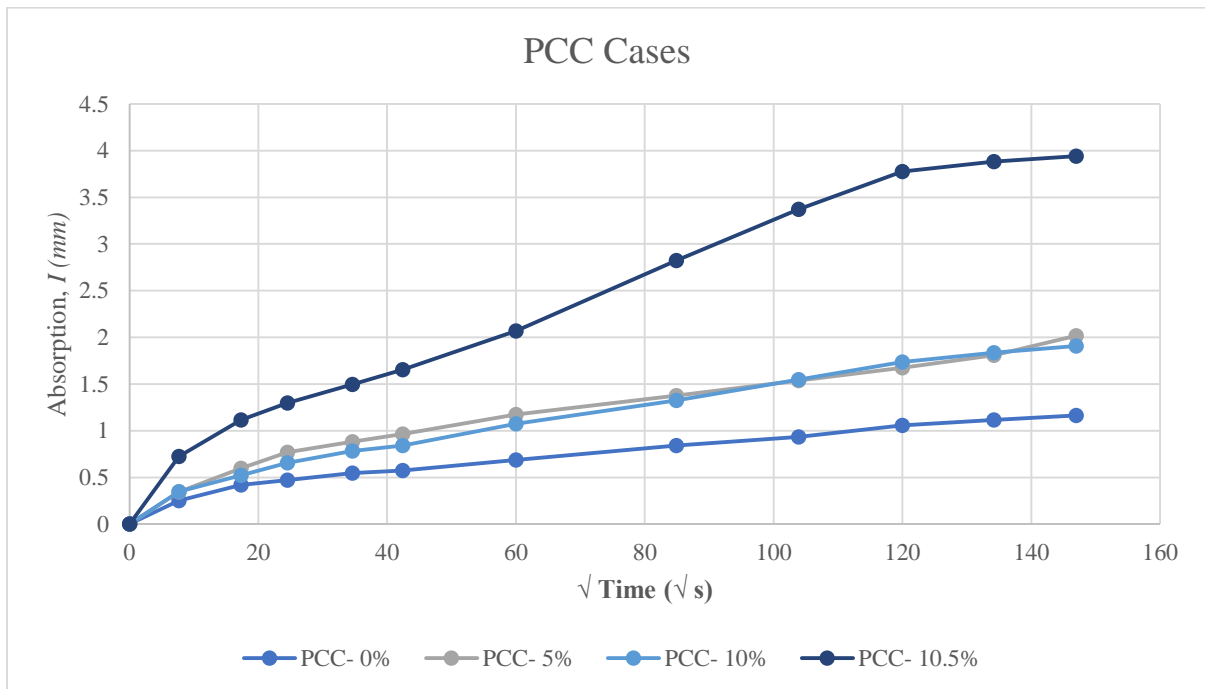

Graph 6: Absorption for all CEM Type-II cases

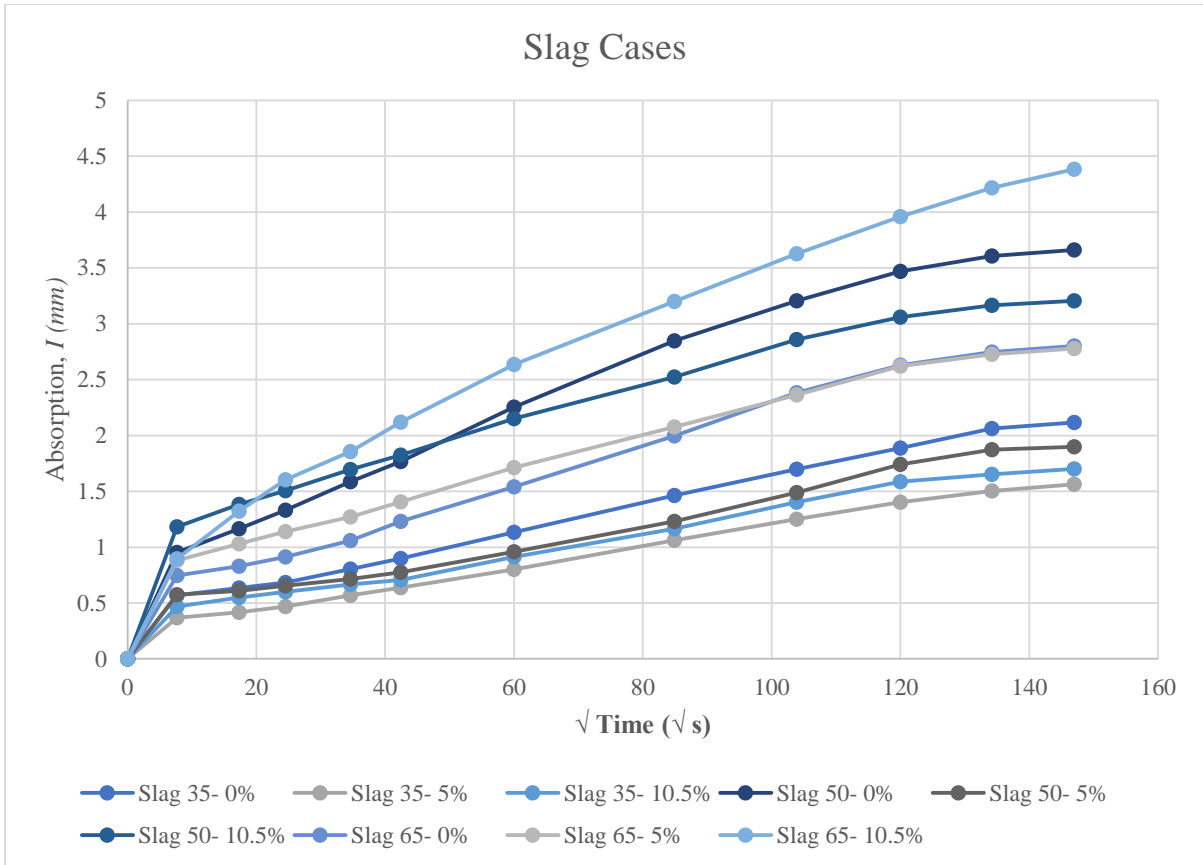

Graph 7: Absorption for all Slag replacing CEM Type-I cases

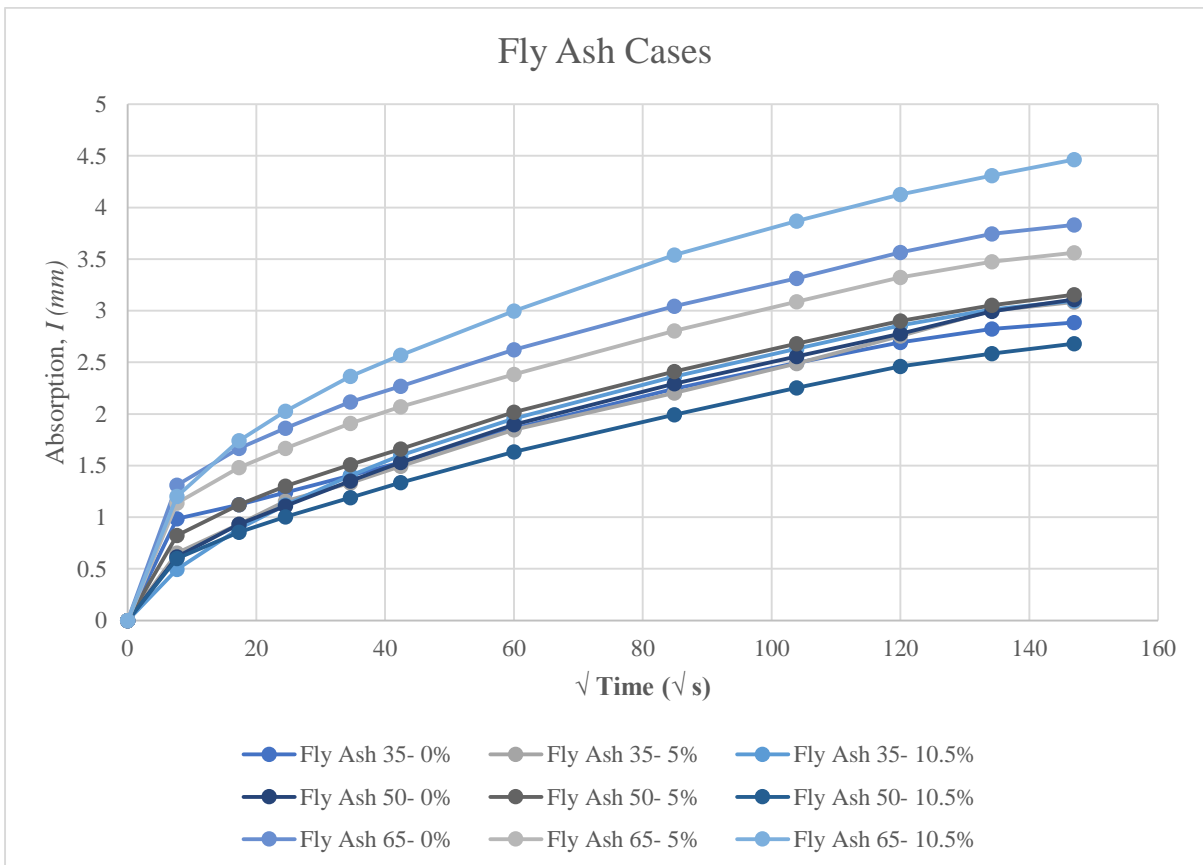

Graph 8: Absorption for all Fly Ash replacing CEM Type-I cases

From the absorption curve, the slope of the curve gives a value for the sorptivity coefficient.

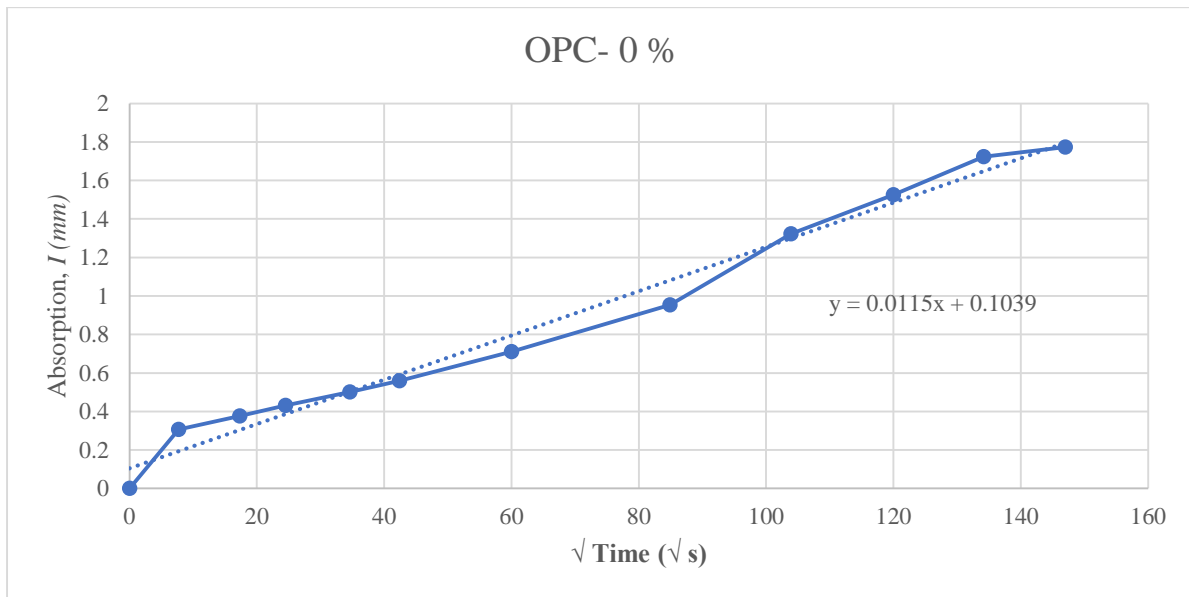

Graph 9: Slope Value from the Absorption vs. √Time Graph

The graph below compares the sorptivity coefficient values' fluctuation to the OPC-0% control scenario. OPC 10.5% has the lowest sorptivity coefficient value, whereas Slag 65-10.5% has the greatest value. CEM Type-I cases displayed the best values among all the cases.

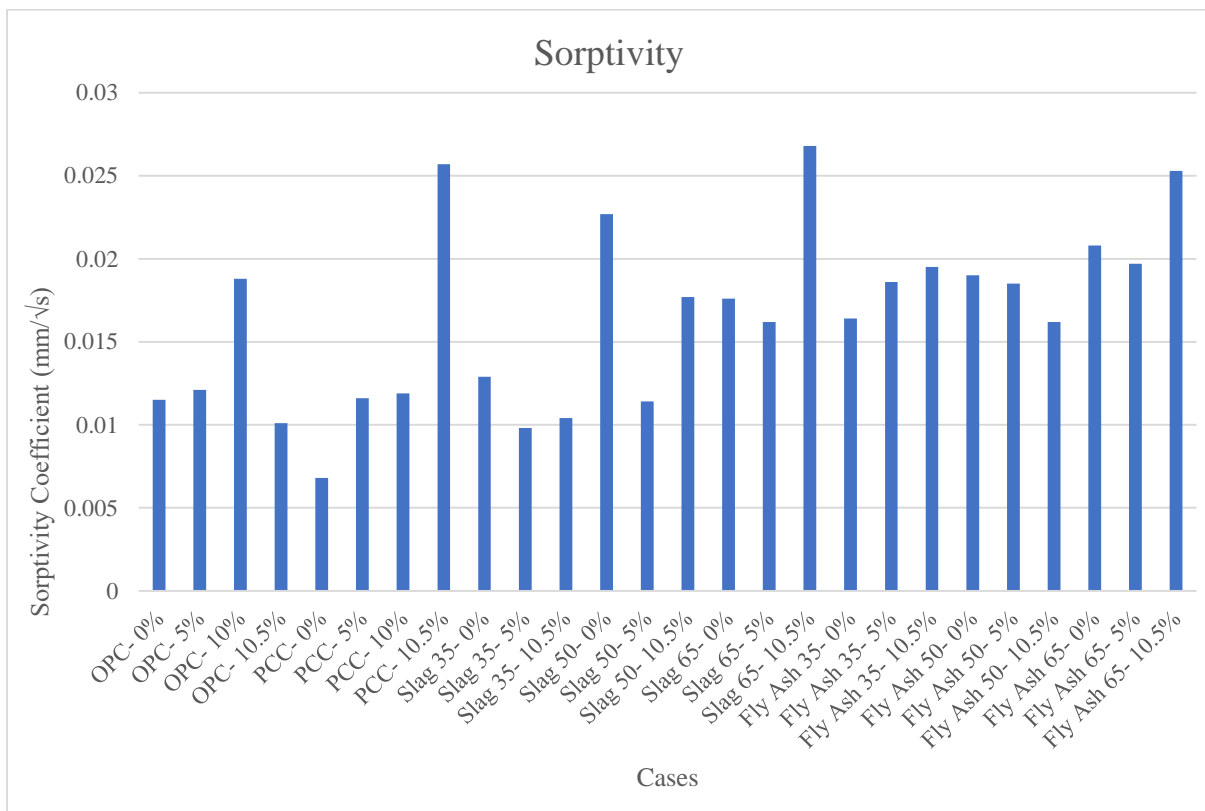

Graph 10: Sorptivity Coefficient Value for All Cases

### 4.3 UPV Test

The following graph illustrates ultrasonic pulse velocities for each example, with Fly Ash 65-10.5% showing the lowest value overall and PCC- 0% showing the greatest value overall.

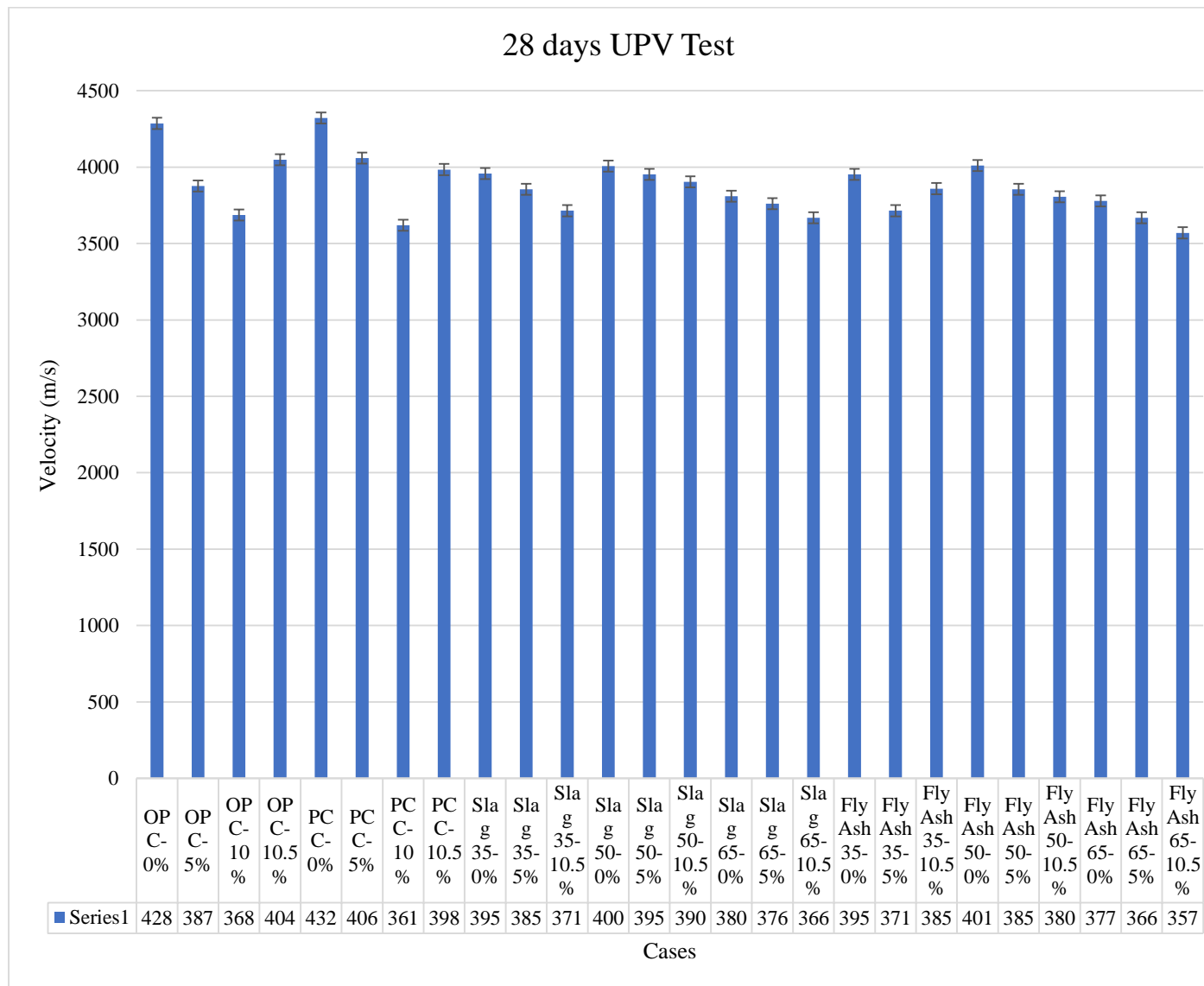

Graph 11: UPV Test Data



## Chapter: 5 Conclusion and Recommendations

### 5.1 Introduction

This thorough study's research sought to better understand the crucial characteristics of concrete mixes made with various cementitious materials and replacement rates for recycled concrete slurry waste (RCSW). The results of this study offer important new information on the functionality, long-term viability, and prospective uses of these concrete mixes in actual building projects.

### 5.2 Conclusions

#### 5.2.1 Compressive Strength

The compressive strength test, a fundamental indicator of concrete performance, revealed that the optimal mix design was OPC-10.5%, exhibiting the highest strength value among all cases. This indicates the superior mechanical properties of this mixture, making it a promising choice for high-strength concrete applications. On the other hand, instances with Fly Ash replacing part of CEM Type-I experienced the lowest strength values, suggesting the need for careful consideration when incorporating Fly Ash as a cementitious component.

The strength variation analysis of instances with RCSW replacement rates of 5% and 10.5% compared to the control case of OPC-0% provided valuable insights into the behavior of the concrete mixtures over time. Interestingly, only OPC-5% and OPC-10.5% displayed the ability to boost their strength compared to the optimal case. This finding highlights the importance of selecting an appropriate RCSW replacement rate to enhance concrete performance. Furthermore, the OPC-10.5% instance demonstrated a significant increase in strength from 56 to 90 days, indicating its potential for long-term durability, making it a favorable choice for infrastructure projects requiring prolonged service life. The following reasons explain why using concrete slurry as a partial replacement for fine aggregate in mortar results in better compressive strength:

- **Particle Packing and Filling Effect:** Concrete slurry's small particles can fill in spaces left by the mortar mix's bigger aggregate particles. This better particle packing may result in a structure that is denser and more compact, which would boost compressive strength.
- **Hydration of Cement Particles:** During the mixing process, cement particles partially hydrated and are now present in the concrete slurry. These partly hydrated cement particles can continue to contribute to the overall cementitious process when added to mortar, which will increase the mixture's strength and encourage the production of new linkages.
- **Improved Interface Bonding:** At the interface between the aggregate particles and the mortar matrix, the fine particles in the concrete slurry can create stronger mechanical linkages. A combination that is more cohesive and well-integrated as a result of this better bonding may have a higher compressive strength.

- **Reduced Porosity:** The inclusion of concrete slurry may cause the overall porosity of the mortar mixture to decrease. Less porosity indicates that the mixture has fewer voids and gaps, which can increase compressive strength by reducing stress concentration spots and improving load-bearing capacity.

### 5.2.2 *Water Absorption (Sorptivity)*

The sorptivity analysis, assessing the ability of concrete to absorb and retain water, revealed that OPC-10.5% exhibited the lowest sorptivity coefficient value among all slurry replacement cases, indicating its potential for enhanced resistance to water penetration. Under the following conditions, replacing some of the fine aggregates with concrete slurry may result in less water absorption. This is why:

- **Less Porosity:** The finer aggregate particles and cementitious elements in concrete slurry fill the spaces between the bigger aggregate particles. As a result, the microstructure becomes more dense and less porous. Because there are fewer open areas for water to enter, lower porosity often results in decreased water absorption.
- **Improved Packing Density:** The slurry's finer particles increase the mixture's overall packing density. Lower water absorption can result from particles being more tightly packed together since there is less room for water to permeate.
- **Improved Surface Coating:** When concrete slurry was utilized in place of some of the fine aggregate, it created a thin layer of coating on the larger aggregate particles' surfaces. This coating serves as a barrier, reducing the number of entry points for water into the concrete and lowering water absorption.
- **Improved Bonding:** The cementitious ingredients in the slurry helped the slurry bond with the other elements of the concrete mixture to be stronger. The possibility of water infiltration and absorption was decreased because of the stronger bonds, which produced a more homogenous structure.

On the other hand, Slag replacement cases displayed a bit higher sorptivity coefficient value, suggesting the need for careful consideration when incorporating Slag as a cementitious component. Under particular conditions, using concrete slurry as a partial replacement for fine aggregate may result in increased water absorption for the following reasons:

- **Porous Structure:** When compared to OPC particles, blast furnace slag particles frequently have a more porous structure. This porosity may make it easier for water to absorb into the slag particles, increasing the concrete's total capacity to absorb water.
- **Slow Hydration:** When compared to OPC particles, slag particles usually hydrate more slowly. The more open and porous microstructure that results from this delayed hydration process may improve the concrete's permeability and water absorption.
- **Reduced Density:** In comparison to OPC particles, slag particles are often less dense. Due to its lower density, concrete might have a larger porosity, which increases its susceptibility to water absorption.
- **Filler Effect:** Slag can occasionally act as a filler ingredient, taking up space in the concrete mix without considerably boosting its strength. As a result, the concrete may develop pores and spaces, which may enhance water absorption.

Fly ash replacement cases showed the overall highest values of sorptivity coefficient. Due to the intrinsic qualities of fly ash, water absorption may increase when fly ash is used as a partial

replacement for Ordinary Portland Cement (OPC). The waste product of burning coal in power plants is called fly ash, which is a fine powder. Fly ash particles used in concrete may have a porous structure that can absorb water and raise the overall porosity of the mixture.

Overall, CEM Type-I cases demonstrated the best sorptivity values among all the cases, underscoring the importance of the cement type selection in optimizing concrete performance.

### **5.3 Limitations of Study**

Despite the valuable findings presented in this research, certain limitations should be acknowledged. The implication of trace elements in each RCSW sample remains unexplored. These trace elements may play a significant role, both positively and adversely, in the performance of concrete mixtures. Further analysis and understanding of their impact can help optimize concrete design and performance. Additionally, the loss of water from RCSW during long-term storage requires quantification to improve experimental accuracy. Furthermore, maintaining a constant water level during experimentation is essential to ensure consistent and reliable results. The quality of RCSW, including the numerical quantity and the effects of pH, salts, microplastics, and other factors, remains unexplored and should be the focus of future research.

### **5.4 Recommendations for Future Research**

In light of the significant findings and limitations, several recommendations for future research can be made. Further studies on the long-term behavior and environmental impact of these concrete mixtures will provide additional insights and practical applications in the construction industry. Exploring the quantity and effect of trace elements in RCSW will shed light on their contribution to concrete performance. Interaction with different types of coarse aggregates will enhance the understanding of their combined effects and applicability in specific construction scenarios. Additionally, investigating the usability of different admixtures in combination with RCSW will broaden the options for optimizing concrete mixtures for specific project requirements.

In conclusion, this research contributes valuable information to the field of sustainable construction practices and the development of high-performance concrete mixtures. The findings highlight the importance of careful material selection and optimal RCSW replacement rates to achieve desired mechanical and durability properties. Engineers and construction professionals can use this information to make informed decisions and design sustainable concrete structures with enhanced performance characteristics. The potential applications of these concrete mixtures are vast, ranging from high-strength infrastructure projects to durable and sustainable construction solutions. Future research focusing on the long-term behavior, environmental impact, and specific effects of trace elements will further expand the applicability and understanding of the study's results, paving the way for innovative and sustainable construction practices. Overall, this research contributes to the advancement of sustainable construction practices, promoting environmental stewardship, and the continued development of high-performance concrete mixtures for diverse infrastructure projects.

## References

---

- Iizuka, A., Sakai, Y., Yamasaki, A., Honma, M., Hayakawa, Y., & Yanagisawa, Y. (2012). Bench-scale operation of a concrete sludge recycling plant. *Industrial and Engineering Chemistry Research*, 51(17), 6099–6104. <https://doi.org/10.1021/ie300620u>
- Marvila, M. T., Azevedo, A. R. G., Alexandre, J., Vieira, C. M. F., Zanelato, E. B., Delaqua, G. C. G., Xavier, G. C., & Monteiro, S. N. (2020). Study of the Compressive Strength of Mortars as a Function of Material Composition, Workability, and Specimen Geometry. *Modeling and Simulation in Engineering*, 2020. <https://doi.org/10.1155/2020/1676190>
- ASTM C1585-13. (2013). Standard Test Method for Measurement of Rate of Absorption of Water by Hydraulic Cement Concretes. *ASTM International*, 41(147), 1–6. <https://doi.org/10.1520/C1585-13.2>
- Lorenzi, A., Tisbierck, F. T., Carlos, L., & Filho, S. (2007). *Ultrasonic Pulse Velocity Analysis in Concrete Specimens 2. Concrete Evaluation considering Nondestructive Testing*. June 2014.
- Ghraid, A. M., Heath, A., Paine, K., & Kronz, M. Al. (2020). Waste wash-water recycling in ready-mix concrete plants. *Environments - MDPI*, 7(12), 1–15. <https://doi.org/10.3390/environments7120108>
- View of Recycling of fresh concrete exceeding and wash water in concrete mixing plants / Materiales de Construcción*. (n.d.). Retrieved July 31, 2023, from <https://materconstrucc.revistas.csic.es/index.php/materconstrucc/article/view/1448/1603>
- Arunvivek G, Maheswaran G, Kumar SS (2015) Eco-friendly solution to mitigate the toxic effects of hazardous construction industry waste by reusing in concrete for pollution control. *Nat Environ Pollut Technol* 14:963
- Hasanbeigi, A., Price, L., & Lin, E. (2012). Emerging energy-efficiency and CO<sub>2</sub> emission-reduction technologies for cement and concrete production: A technical review. *Renewable and Sustainable Energy Reviews*, 16(8), 6220–6238. <https://doi.org/10.1016/j.rser.2012.07.019>
- Kazaz, A., & Ulubeyli, S. (2016). Current Methods for the Utilization of the Fresh Concrete Waste Returned to Batching Plants. *Procedia Engineering*, 161, 42–46. <https://doi.org/10.1016/j.proeng.2016.08.495>
- Maddalena, R., Roberts, J. J., & Hamilton, A. (2018). Can Portland cement be replaced by low-carbon alternative materials? A study on the thermal properties and carbon emissions of innovative blocks of cement. *Journal of Cleaner Production*, 186, 933–942. <https://doi.org/10.1016/j.jclepro.2018.02.138>

- Correia, S. L., Souza, F. L., Dienstmann, G., & Segadães, A. M. (2009). Assessment of the recycling potential of fresh concrete waste using a factorial design of experiments. *Waste Management*, 29(11), 2886–2891. <https://doi.org/10.1016/j.wasman.2009.06.014>
- Tam, V. W. Y. (2008). Economic comparison of concrete recycling: A case study approach. *Resources, Conservation, and Recycling*, 52(5), 821–828. <https://doi.org/10.1016/j.resconrec.2007.12.001>
- Kushwah, R. P. S., Sharma, I. C., & Chaurasia, P. (2015). Utilization of “marble slurry” In cement concrete replacing fine aggregate. *American Journal of Engineering Research (AJER)*, 4(1), 55–58.
- R. Vinai et al., “Sustainable binders for concrete: A structured approach from waste screening to binder composition development,” *Heron*, vol. 60, no. 1–2, pp. 27–57, 2015.
- Wu, Y., Qiao, W. G., Li, Y. Z., Liu, H. N., Tang, C., Zhang, S., Zhang, X. L., Lu, J. G., & Chen, P. C. (2022). Research on Cement Slurry Using Silica Fume Instead of Fly Ash. *Materials*, 15(16), 1–25. <https://doi.org/10.3390/ma15165626>
- Zimina, D. A., & Nutskova, M. V. (2019). Research of technological properties of cement slurries based on cement with expanding additives, portland, and magnesia cement. *IOP Conference Series: Materials Science and Engineering*, 666(1). <https://doi.org/10.1088/1757-899X/666/1/012066>
- Iizuka, A., Sasaki, T., Honma, M., Yoshida, H., Hayakawa, Y., Yanagisawa, Y., & Yamasaki, A. (2017). Pilot-scale operation of a Concrete Sludge Recycling Plant and Simultaneous Production of Calcium Carbonate. *Chemical Engineering Communications*, 204(1), 79–85. <https://doi.org/10.1080/00986445.2016.1235564>
- K, B. J., & Vivek, P. (2019). *Effect of Cement Slurry Mixed Recycled Aggregate Concrete on Strength Properties*. 6(3), 77–81.
- Hossain, M. U., Xuan, D., & Poon, C. S. (2017). Sustainable management and utilization of concrete slurry waste: A case study in Hong Kong. *Waste Management*, 61, 397–404. <https://doi.org/10.1016/j.wasman.2017.01.038>
- He, X., Zheng, Z., Ma, M., Su, Y., Yang, J., Tan, H., Wang, Y., & Strnadl, B. (2020). New treatment technology: The use of wet-milling concrete slurry waste to substitute cement. *Journal of Cleaner Production*, 242, 118347. <https://doi.org/10.1016/j.jclepro.2019.118347>
- Xuan, D., Zhan, B., Poon, C. S., & Zheng, W. (2016). Innovative reuse of concrete slurry waste from ready-mixed concrete plants in construction products. *Journal of Hazardous Materials*, 312, 65–72. <https://doi.org/10.1016/j.jhazmat.2016.03.036>
- Prajapati, L., Patel, I. N., & Agrawal, V. V. (2014). Analysis Of the Strength And Durability Of The Concrete Partially Replaced By The Ceramic Slurry Waste Powder. *International Journal of Emerging Technology and Advanced Engineering (IJETAETAE)*, 4(3), 725–729.

- Chen, Z., Lai, G., Fang, Y., Zhang, X., & Guo, Y. (2019). Research and preparation of waste cement slurry as concrete admixture. *IOP Conference Series: Earth and Environmental Science*, 358(5), 18–23. <https://doi.org/10.1088/1755-1315/358/5/052025>
- Strnadel, B., Ma, M., He, X., Tan, H., Wang, Y., Su, Y., Zheng, T., & Zhao, R. (2021). A comparative study on concrete slurry waste: performance optimization from the wet-milling process. *Materials and Structures/Materiaux et Constructions*, 54(5). <https://doi.org/10.1617/s11527-021-01771-1>
- Correia, S. L., Souza, F. L., Dienstmann, G., & Segadães, A. M. (2009). Assessment of the recycling potential of fresh concrete waste using a factorial design of experiments. *Waste Management*, 29(11), 2886–2891. <https://doi.org/10.1016/j.wasman.2009.06.014>
- Guthrie, W. S., Smith, E. D. S., Stevens, R. J., & Emery, T. W. (2020). Cement Slurry Application Using a Ready-Mixed Concrete Truck: Best Practices for Urban Pavement Construction. *2020 Intermountain Engineering, Technology and Computing, IETC 2020*. <https://doi.org/10.1109/IETC47856.2020.9249155>
- Reiterman, P., Mondschein, P., Doušová, B., Davidová, V., & Keppert, M. (2022). Utilization of concrete slurry waste for soil stabilization. *Case Studies in Construction Materials*, 16(March). <https://doi.org/10.1016/j.cscm.2022.e00900>
- Iizuka, A., Sasaki, T., Honma, M., Yoshida, H., Hayakawa, Y., Yanagisawa, Y., & Yamasaki, A. (2017). Pilot-scale operation of a Concrete Sludge Recycling Plant and Simultaneous Production of Calcium Carbonate. *Chemical Engineering Communications*, 204(1), 79–85. <https://doi.org/10.1080/00986445.2016.1235564>
- ASTM Standard. (2013). Standard Test Method for Determination of Moisture in Plastics by Loss in Weight. *ASTM International, West Conshohocken, PA*, i, 1–5. <https://doi.org/10.1520/D6980-12.2>
- ASTM I. (1999). C109C109.Pdf. *ASTM International*, 04(May), 1–6.
- ASTM C1585-13. (2013). Standard Test Method for Measurement of Rate of Absorption of Water by Hydraulic Cement Concretes. *ASTM International*, 41(147), 1–6.
- ASTM. (2008). D792-08 Standard Test Methods for Density and Specific Gravity (Relative Density) of Plastics by Displacement. *American Society for Testing and Materials*, 6.

## Appendices

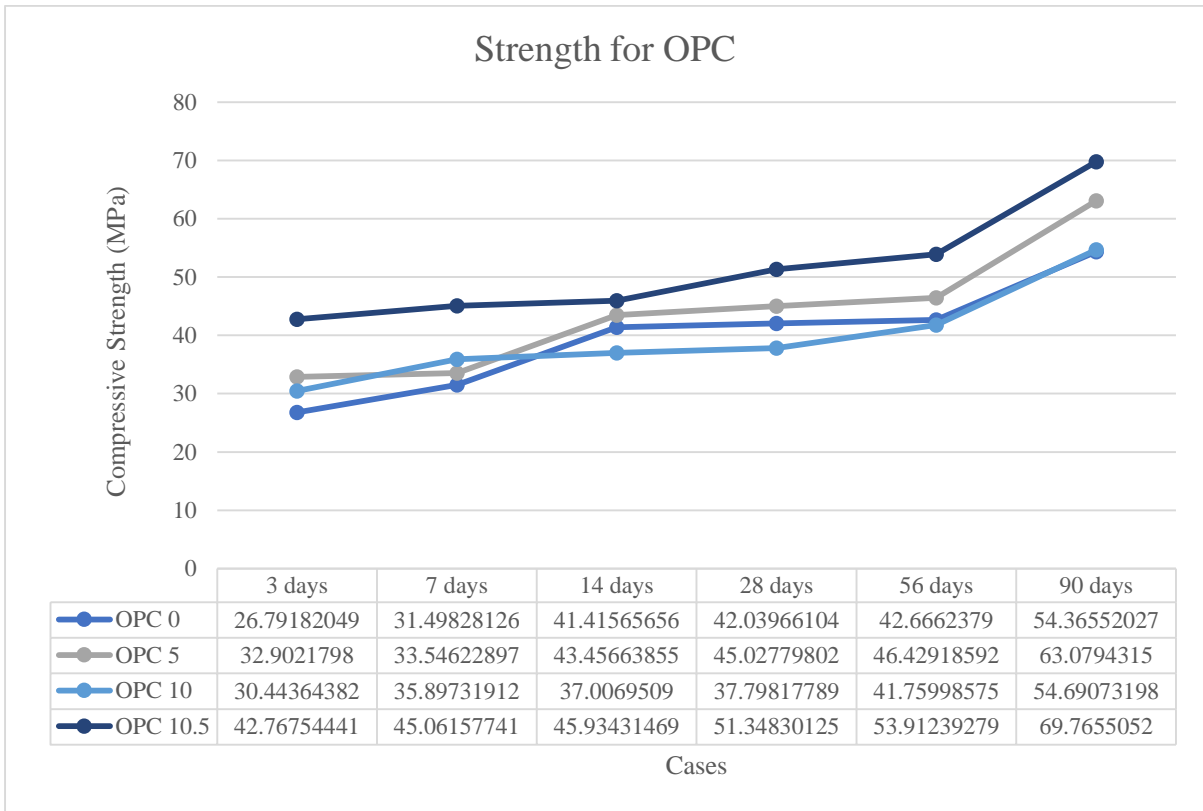

Graph 12: Compressive Strength Data for CEM Type-I

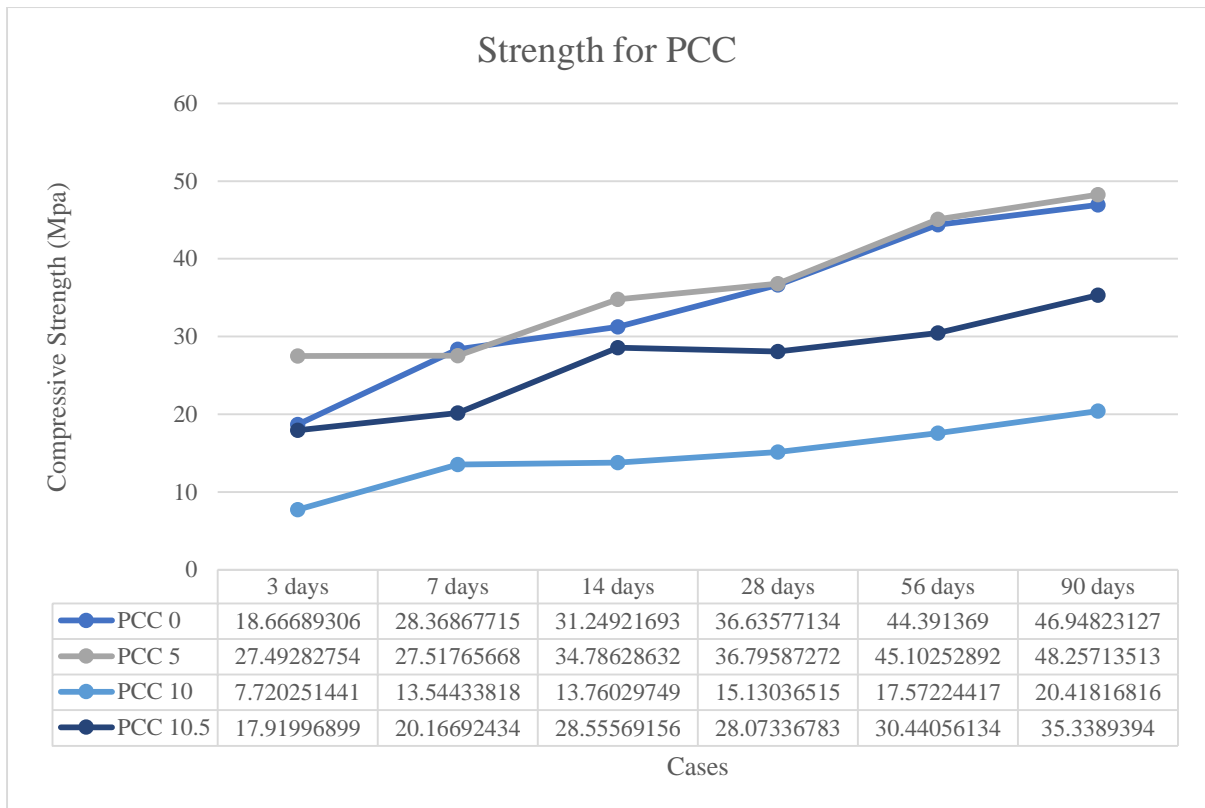

Graph 13: Compressive Strength Data for CEM Type-II

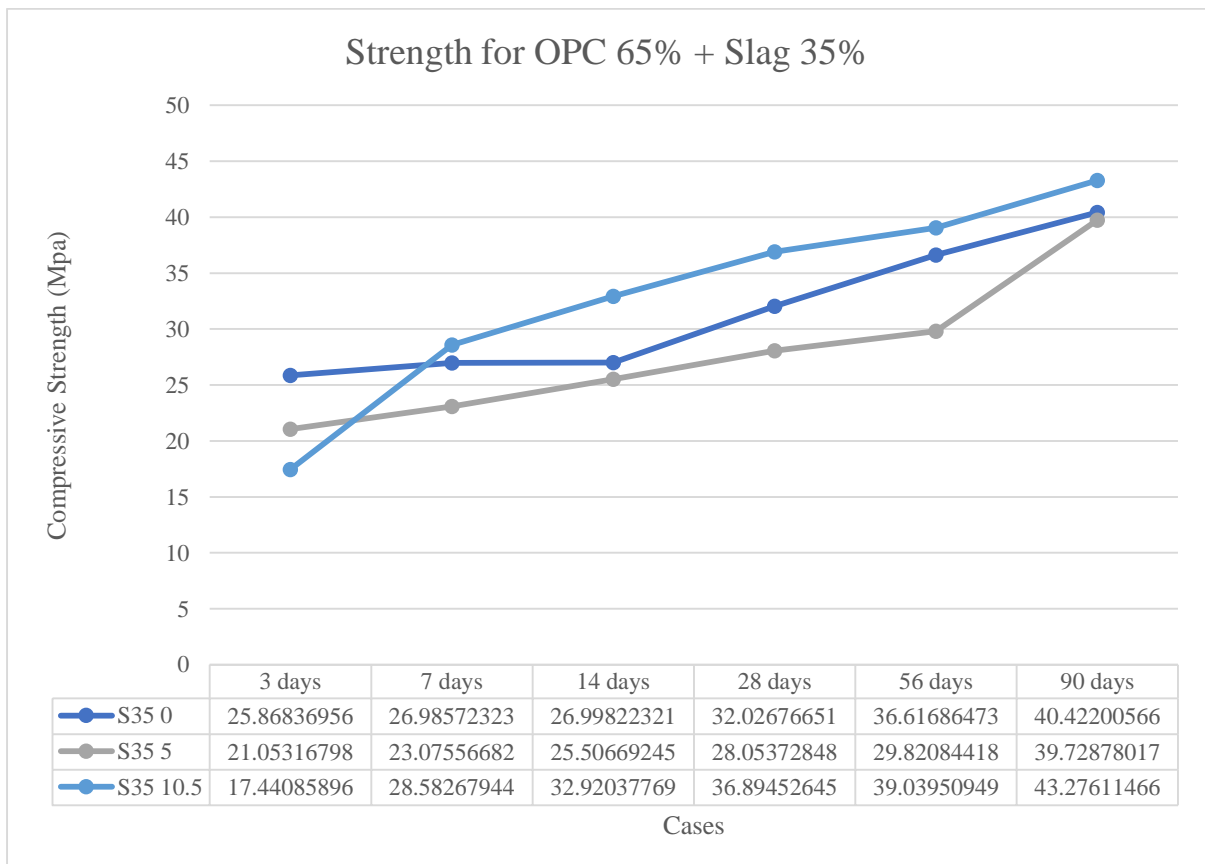

Graph 14: Compressive Strength Data for Slag replacing 35% of CEM Type-I



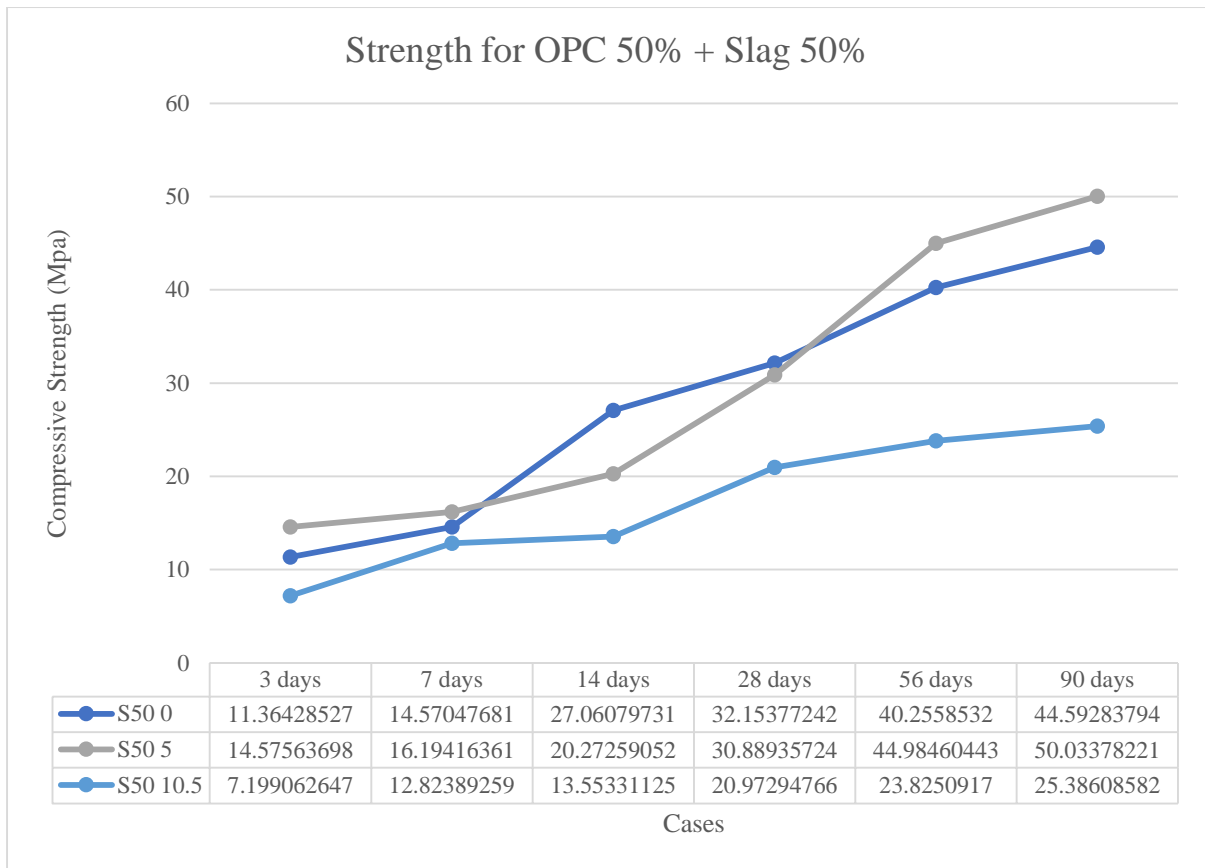

Graph 15: Compressive Strength Data for Slag replacing 50% of CEM Type-I

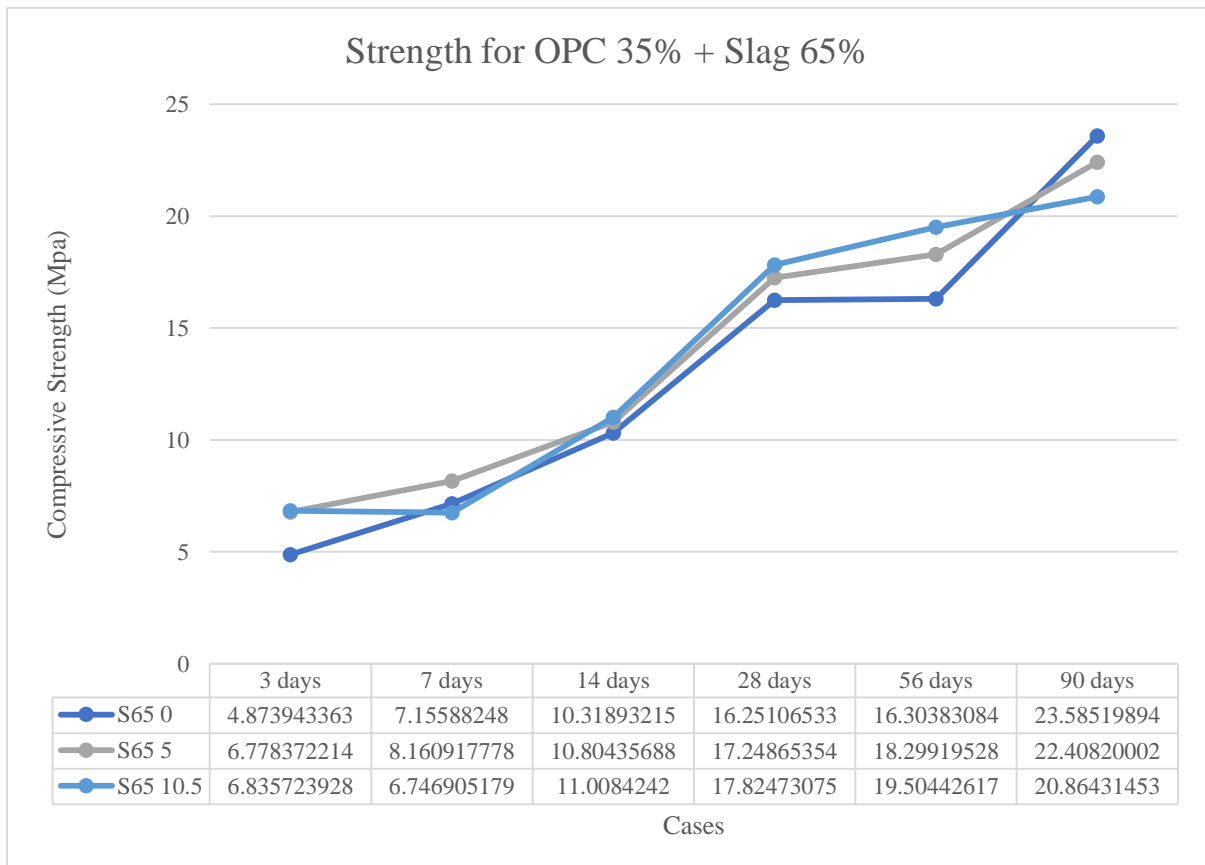

Graph 16: Compressive Strength Data for Slag replacing 65% of CEM Type-I

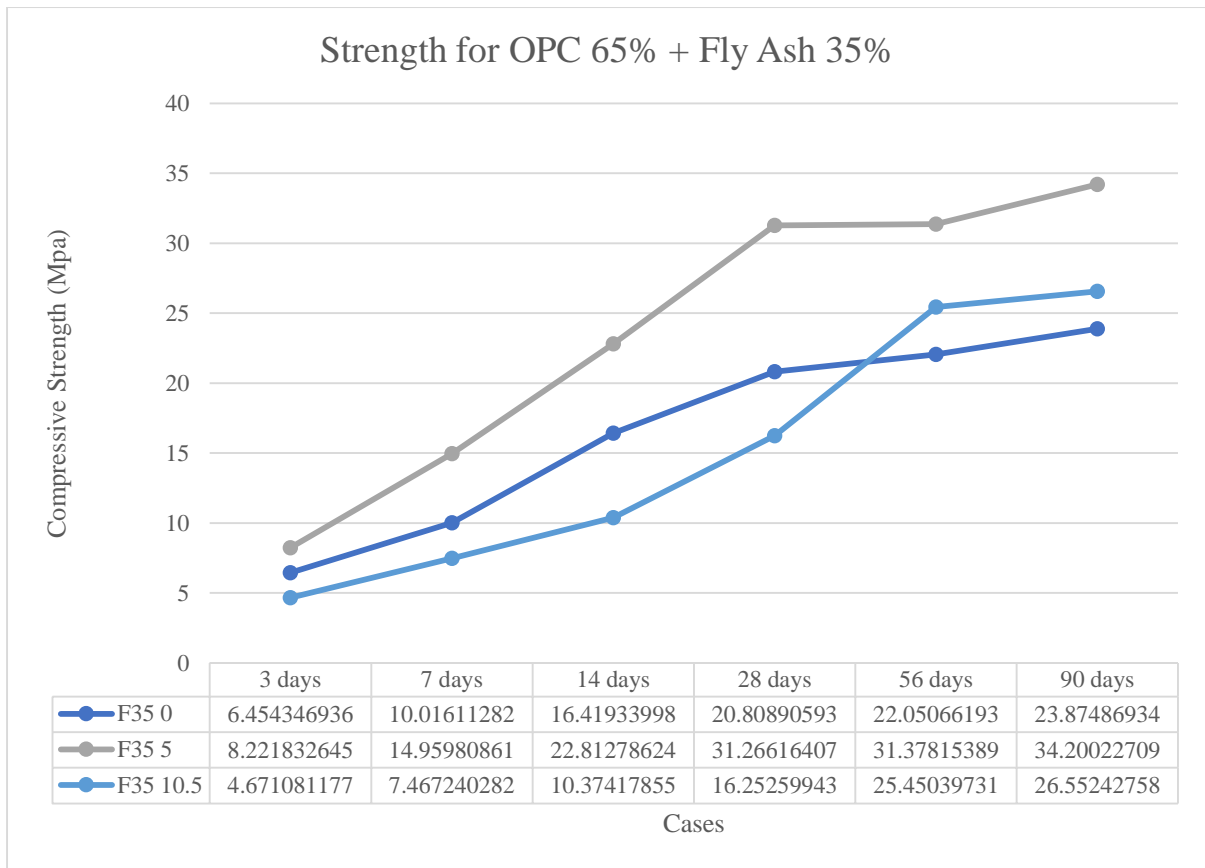

Graph 17: Compressive Strength Data for Fly Ash replacing 35% of CEM Type-I

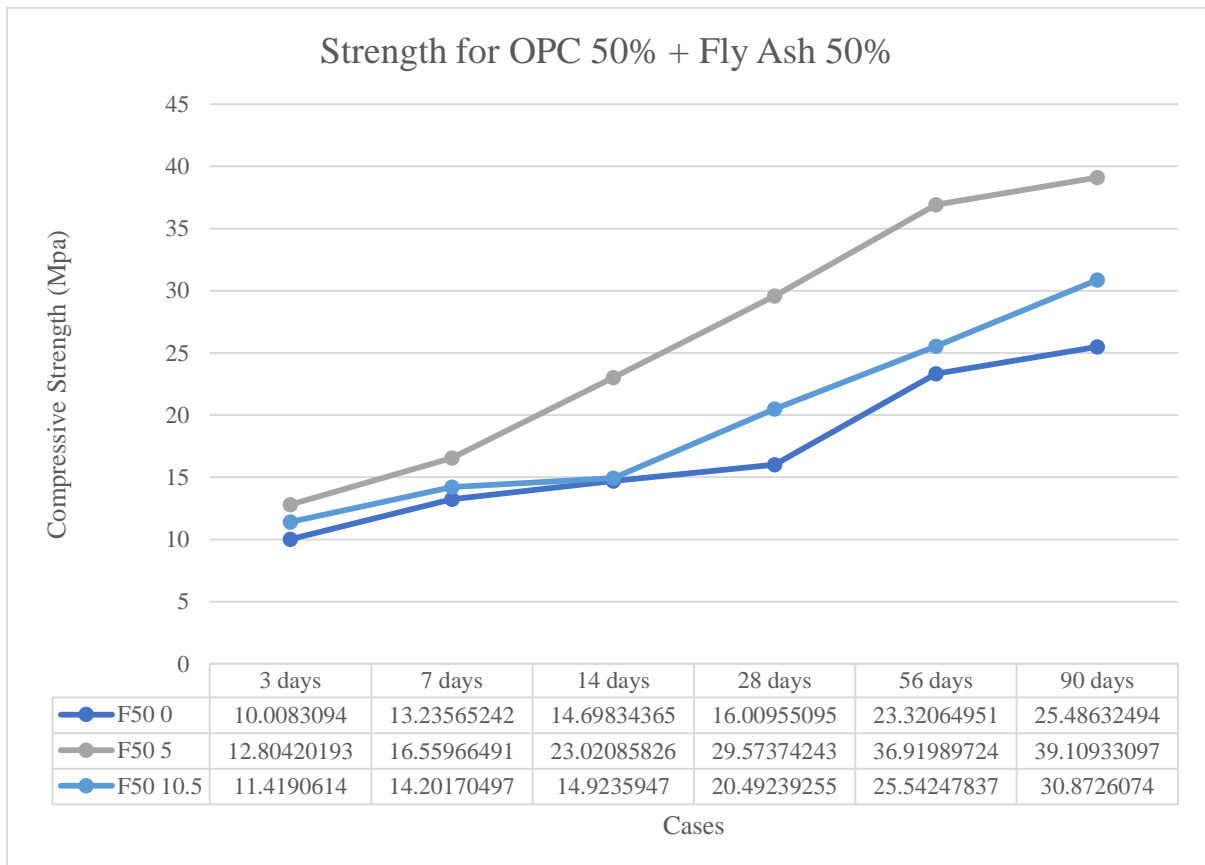

Graph 18: Compressive Strength Data for Fly Ash replacing 50% of CEM Type-I

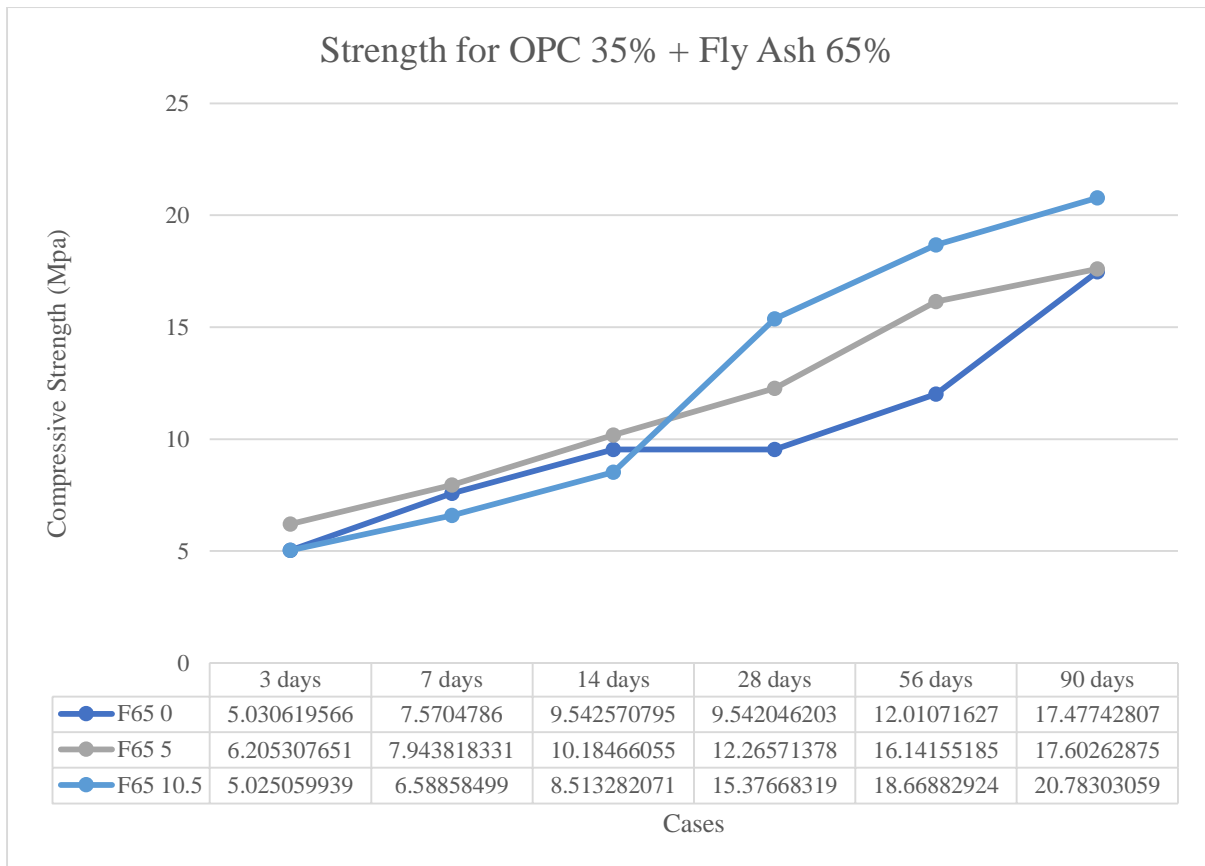

Graph 19: Compressive Strength Data for Fly Ash replacing 65% of CEM Type-I

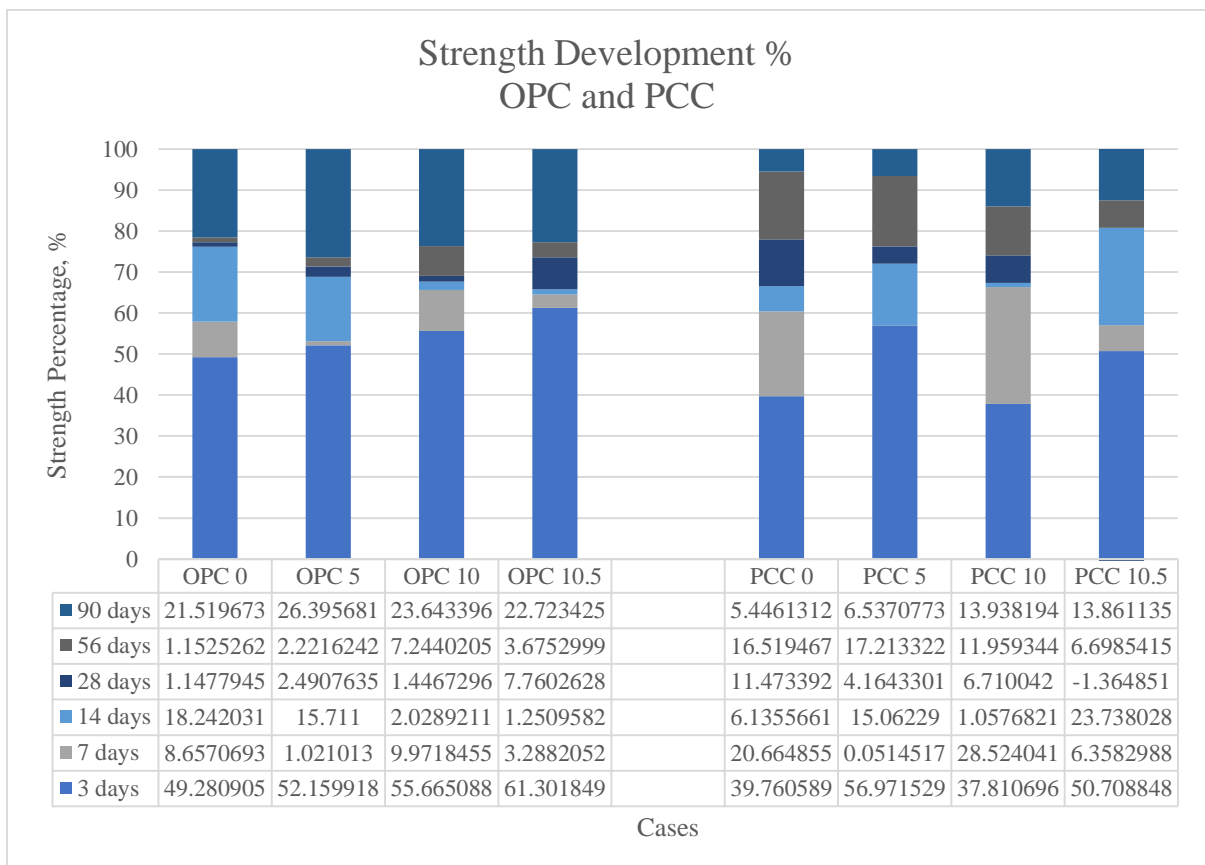

Graph 20: Strength Development Percentage over 90 days For CEM Type I & II cases

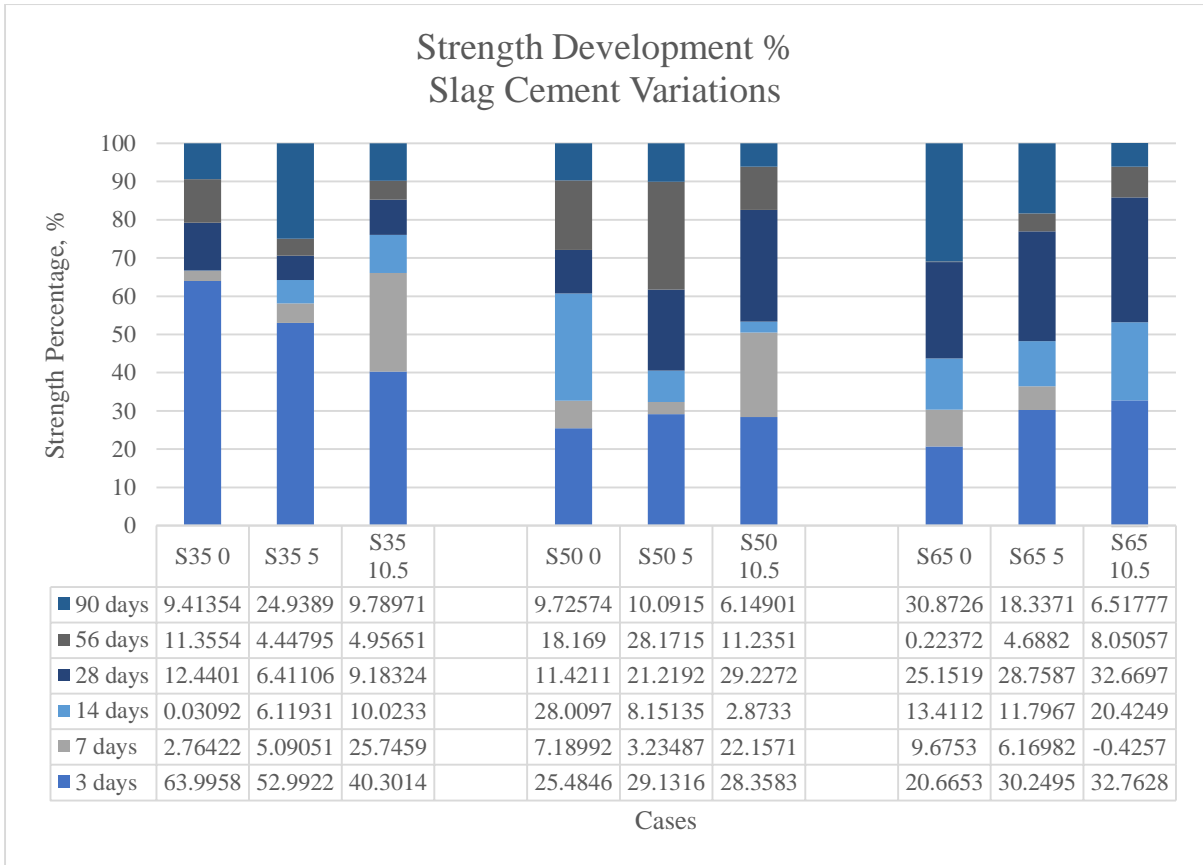

Graph 21: Strength Development Percentage over 90 days For Slag replacing CEM Type-I cases

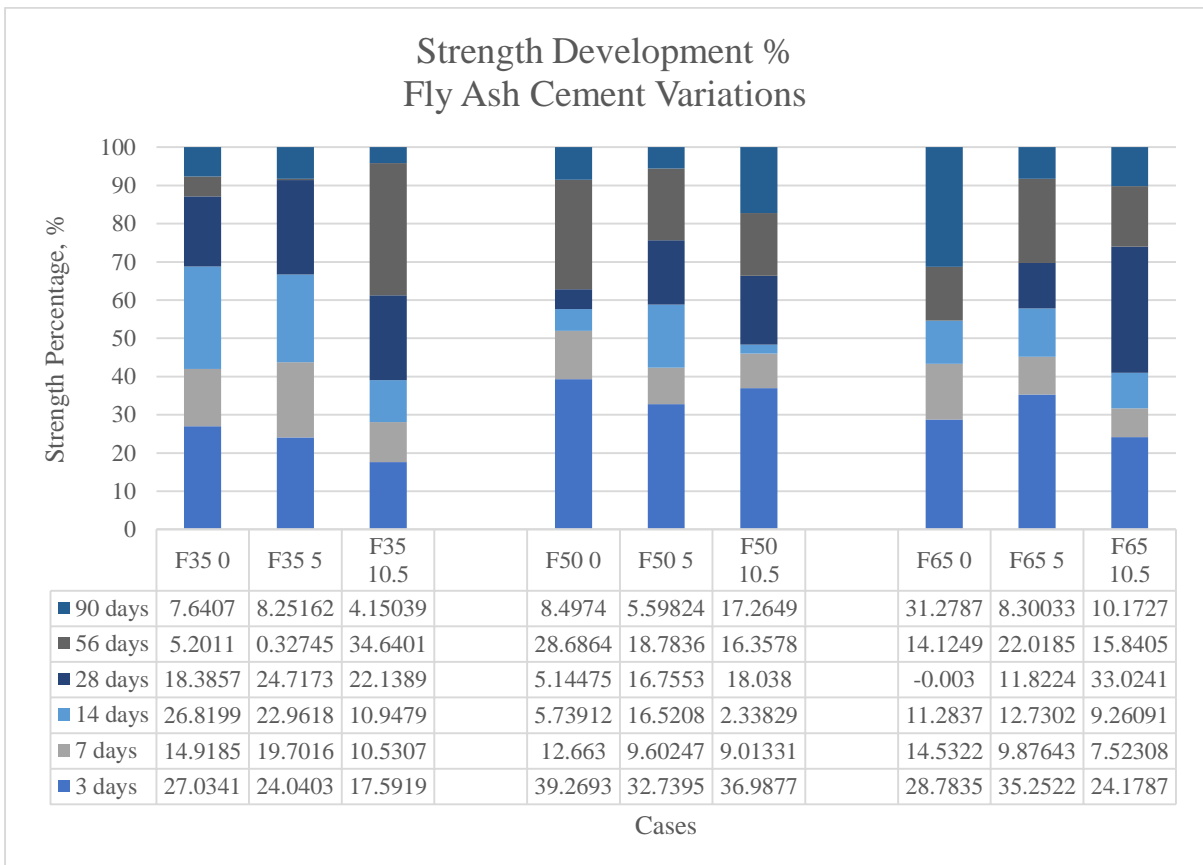

Graph 22: Strength Development Percentage over 90 days For Fly Ash Replacing CEM Type-I cases

