

---

# LAGRANGIAN FORMULATION FOR CIRCUIT THEORY AND ANALYSIS

By

**Md. Shadman Matin (132456)**  
**Jamil Reza Chowdhury (132448)**  
**Md. Kamrul Hasan (132446)**

A Thesis Submitted to the Academic Faculty in Partial Fulfillment of the  
Requirements for the Degree of

**BACHELOR OF SCIENCE IN ELECTRICAL AND ELECTRONIC  
ENGINEERING**



Department of Electrical and Electronic Engineering  
**Islamic University of Technology (IUT)**  
Gazipur, Bangladesh

November 2017

---

## Declaration of Candidate

It is hereby declared that this thesis or any part of it has not been submitted elsewhere for the award of any Degree or Diploma.

-----  
**Prof. Dr. Md. Ashraful Hoque**

Supervisor, Professor and Head of the Department,  
Department of Electrical and Electronic Engineering,  
Islamic University of Technology (IUT),  
Boardbazar, Gazipur-1704.

Date: .....

---

**Md. Kamrul Hasan**

Student No: 132446  
Academic Year: 2016-2017  
Date: .....

---

**Md. Shadman Matin**

Student No. 132456  
Academic Year: 2016-2017  
Date: .....

---

**Jamil Reza Chowdhury**

Student No. 132448  
Academic Year: 2016-2017  
Date: .....

---

## Table of Contents

<b>List of Figures.....</b>	<b>iii</b>
<b>Acknowledgements.....</b>	<b>iv</b>
<b>Abstract.....</b>	<b>v</b>
<b>1 Birth of a New Circuit Concept.....</b>	<b>1</b>
1.1 BIRTH OF NEWTONIAN MECHANICS.....	1
1.2 MODIFICATIONS OF NEWTONIAN MECHANICS .....	1
1.3 CONSERVATION LAWS .....	2
1.4 ALL ABOUT MINIMUM.....	3
1.5 MINIMIZATION OG ENERGY DISTRIBUTION IN CIRCUITS .....	3
1.6 AN EXAMPLE(FROM REFERENCE-1) .....	4
<b>2 Calulus of Variation .....</b>	<b>7</b>
2.1 INTRODUCTION .....	7
2.2 CALCULUS OF VARIATION AND EULER-LAGRANGE EQUATION .....	8
2.3 AN EXAMPLE (FERMAT’S PRINCIPLE) .....	8
<b>3 Lagrangian Mechanics .....</b>	<b>11</b>
3.1 INTRODUCTION .....	11
3.2 LAGRANGE EQUATION .....	11
3.3 SOME APPLICATIONS OF LAGRANGE EQUATION .....	12
<b>4 Modifications of Euler-Lagrange Equation for Circuit Analysis .....</b>	<b>14</b>
4.1 THE ENERGY ANALOGY .....	14
4.2 NEW FACTORS FOR THE MODIFIED EULER-LAGRANGE EQUATION.....	16
<b>5 Series RL, RC, RLC Circuit Analysis by Lagangian Formulation .....</b>	<b>20</b>
5.1 SERIES RC CIRCUIT.....	20
5.2 SERIES RL CIRCUIT .....	21
5.3 SERIES RLC CIRCUIT .....	22
<b>6 Conclusions and Visions .....</b>	<b>24</b>
<b>Reference.....</b>	<b>26</b>

---

## List of Figures

<b>Figure 1.1: A circuit for demonstrating minimization of energy</b> .....	4
<b>Figure 1.2: 3-D plot for energy equation</b> .....	6
<b>Figure 4.1: Configuration for charging a capacitor</b> .....	15
<b>Figure 4.2: Configuration for discharging a capacitor</b> .....	15
<b>Figure 4.3: Setting up constant current in RL DC circuit</b> .....	16
<b>Figure 4.4: Putting off DC voltage source from RL circuit</b> .....	16
<b>Figure 4.5: A circuit for demonstrating the selection of independent currents</b> .....	17
<b>Figure 4.6: A circuit for demonstrating the selection of independent currents</b> .....	18
<b>Figure 5.1: Series RC Circuit</b> .....	20
<b>Figure 5.2: Series RL Circuit</b> .....	21
<b>Figure 5.3: Series RLC Circuit</b> .....	22

## **Acknowledgements**

We would like to thank our thesis supervisor, Dr. Md. Ashraful Hoque, for his continuous guidance and motivation in completing our thesis. His constant demand for making the work more and more suitable has encouraged us a lot. He has been an excellent supervisor throughout our works which finally resulted in some successful outcomes.

We did our work separately. Each chapter is followed by the name of the writer who was involved in the chapter's topics.

Md. Shadman Matin (132456)

Jamil Reza Chowdhury (132448)

Md. Kamrul Hasan (132446)

## **Abstract**

In this thesis, we borrowed the concept of Lagrangian mechanics which is an alternative formulation of classical mechanics to make a new circuit analysis technique. The formula we used here already existed but there were no specific guidelines for the analysis of a given circuit. The three examples we used are two DC types and one AC type. We here have made a step by step analysis technique for analyzing a given circuit. We discussed this formulation in detail. At first we discussed Calculus of Variation and Lagrangian Mechanics with the reference given. Following the discussion, we modified the Euler-Lagrange equation in detail to account for the circuit according to the reference given and then discussed the step by step procedure for analyzing a circuit.

---

# CHAPTER 1

## Birth of a New Circuit Concept

By Md. Shadman Matin

This chapter includes the main motivations behind a new circuit analysis technique under the shadow of the well-known classical mechanics.

### 1.1 Birth of Newtonian Mechanics:

From the birth of Mankind, people have always wondered about the sky. They have asked questions to answer their curiosity. Some questions like why there are stars at night, why do they shine, what makes them to shine in the night sky, how the planets and stars move in the sky, why there are patterns in the stars and the list goes on and on. Whatever the question was, all were began to be answered by Newton, with help from the work from Galileo.

Sir Isaac Newton introduced the concept of force, work, energy, momentum, acceleration, velocity in a mathematical form which none did before. Before everything was kind of intuitive, qualitative, some form of guess work you can tell. For example, the false belief of Aristotle times that, heavier objects fall faster because it is heavier and because this is a common sense. Now, common sense has to be modified when it comes to quantitative analysis of a system. So, we have our tools for analyzing a system mathematically. We have our Newton's laws of motion, laws of force and acceleration.

The fundamental problem was to find the trajectory of a system if we knew the acting force on it. It is more like a prediction that if we knew this and this thing, we will be able to predict the outcome in the future. An excellent prediction was the discovery of planet Neptune which was a direct prediction of Newtonian laws.

### 1.2 MODIFICATIONS OF NEWTONIAN MECHANICS:

All was going well of our mechanics of Newtonian form until it received some modifications. It received two modifications, one is done by Joseph-Louis Lagrange, known as the "Lagrangian

---

Mechanics” and another one by Sir William Rowan Hamilton, known as the “Hamiltonian Mechanics”. These new two formulations are energy based approach. In lagrangian mechanics, we deal with a quantity called lagrangian which by the way is nothing but the quantity formed by (kinetic energy – potential energy) of a given system. Hamiltonian mechanics deals with a quantity called Hamiltonian or the total energy i.e. kinetic energy + potential energy of the system.

Now a basic question can be asked, why on earth suddenly we needed a modification? Wasn't Newtonian version enough? The answer is quite simple. Newtonian mechanics is a vector based and superposition based approach. Like you find an equation for a small quantity and sum it over an interval.

The task is to find a general expression first which sometimes a tedious work is when the system gets too complicated. So, these alternative versions of Newtonian mechanics came to save our day.

We said before that these are energy based approach. That is why we don't have to worry too much about complications of the system, rather focus on energy.

### **1.3 Conservations Laws:**

When we are just learning the basics of analyzing a circuit, the primary tools we are taught are the Kirchoff's Voltage Law (KVL) and Kirchoff's Current Law (KCL). It is good that we taught this that works to solve many circuit problems. But, the thing is that these are just conservations laws. KVL is just the conservation law for energy. The amount of energy provided by the E.M.F on the circuit is either dissipated through the wires and resistors or stored in the electric field of the capacitor or magnetic field of the inductor. It is the same for no amount of energy is lost and none is gained. KCL basically is a charge conservation law. Charge is a fundamental property of the elementary particles and through experiment we have seen that amount of charge is always conserved. So, that same thing goes for the circuit that, the amount of charge going into a node comes out of a node in an infinitesimal of time, that is the time, derivative of charge, the current comes into question.



---

The reason of talking about KVL and KCL is that energy is also conserved. So this is basically a hint that there must be another law governing the circuits based on energy. So, our basic curiosity allows us to divert our attention to an energy based circuit analysis.

#### **1.4 All about minimum:**

Now along with the conservation laws, we have another observation. In nature, energy tends to be in the minimum state. You flip a coin, it gets to the ground and making a dance on floor with the drizzling sound starts to fade. What it is actually doing is, converting its energy into sound and trying to be in the minimum state that is possible for it. If you sprinkle water on the floor, it spreads. If you observe it carefully, it spreads up to a certain area, then it contracts a little and then it stands there. We say that energy has reached a minimum level with its surroundings and the system has become stable.

So, the thing is if a system has some energy, whatever might be the form, it distributes it within it such that the portion being distributed is minimum.

#### **1.5 Minimization of energy distribution in circuits:[Reference-1]**

If you read article 1.4, you are probably convinced what is meant by minimization of energy in a system. Now, whenever we are dealing with circuits, finding the branch current, nodal voltages the basic thing we always forget is the main definition of circuit i.e. what circuit actually in the fundamental level is. Circuit normally means a round trip. Jet aircraft pilots say that we are closing the circuit if it goes back to where it started. E.M.F supplies the whole electrical circuit path with energy and whole electrical path is a system. So this energy must be distributed along the circuit in such a way that the energy is minimized in every element it has. Energy is dissipated as Joule heating in the resistors, stored as energy in the electric field of the capacitors and magnetic field in the inductor.

So, the sense we developed till now tells us that these stored and dissipated energies must be a minimum in this electrical circuit and exactly this was our motivation.

Let's just think yourself as a positive charge carrier what they do when they account for the electrical current. You are being energized by the E.M.F. and your energy is being distributed in the whole path in such a way that your energy in minimum.

### **1.6 An Example (from Reference-1):**

So, let's see an example from Reference-1 to make this concept clearer.

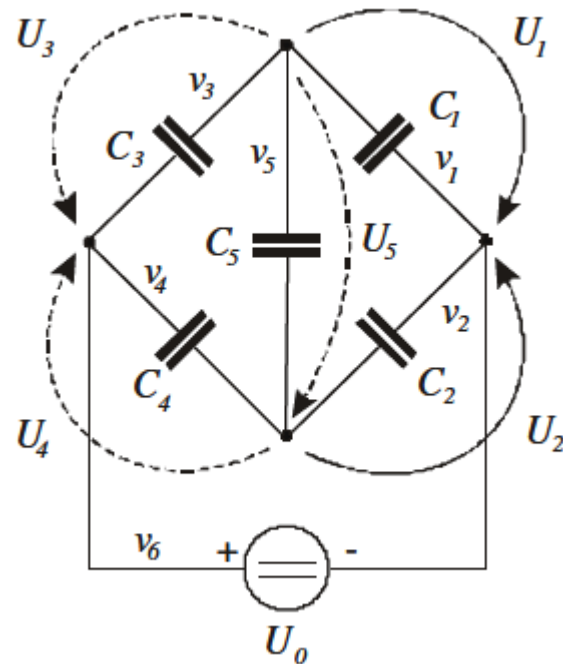

Figure-1.1

Consider this circuit of figure 1.1.  $U_0$  is the E.M.F. here which is providing the energy throughout the circuit. So, according to our previous concept, this energy is stored along the capacitors in such a way that the energy in minimum here. So, let's show you the equations and graphs.

For the numerical values of parameters of branch elements:  $C_1 = 2 \mu\text{F}$ ,  $C_2 = 5 \mu\text{F}$ ,  $C_3 = 1 \mu\text{F}$ ,  $C_4 = 4 \mu\text{F}$ ,  $C_5 = 3 \mu\text{F}$ ,  $U_0 = 100\text{V}$  the expression for energy is

$$W_e = U_1^2 + \frac{5}{2}U_2^2 + \frac{1}{2}(U_1 - 100)^2 + \\ + \frac{1}{2}(U_2 - 100)^2 + \frac{3}{2}(U_1 - U_2)^2$$

Now we have to take partial derivatives and make the gradient equal to zero in order to find the minimum value.

$$\frac{\partial W_e}{\partial U_1} = 0 \Rightarrow 6U_1 - 3U_2 = 100$$

$$\frac{\partial W_e}{\partial U_2} = 0 \Rightarrow -3U_1 + 12U_2 = 400$$

Solving these equations, we get,

$$U_1 = 38.095 \text{ Volts}$$

$$U_2 = 42.857 \text{ Volts}$$

You might not be satisfied with the results. So, let's see the graph in the next page.

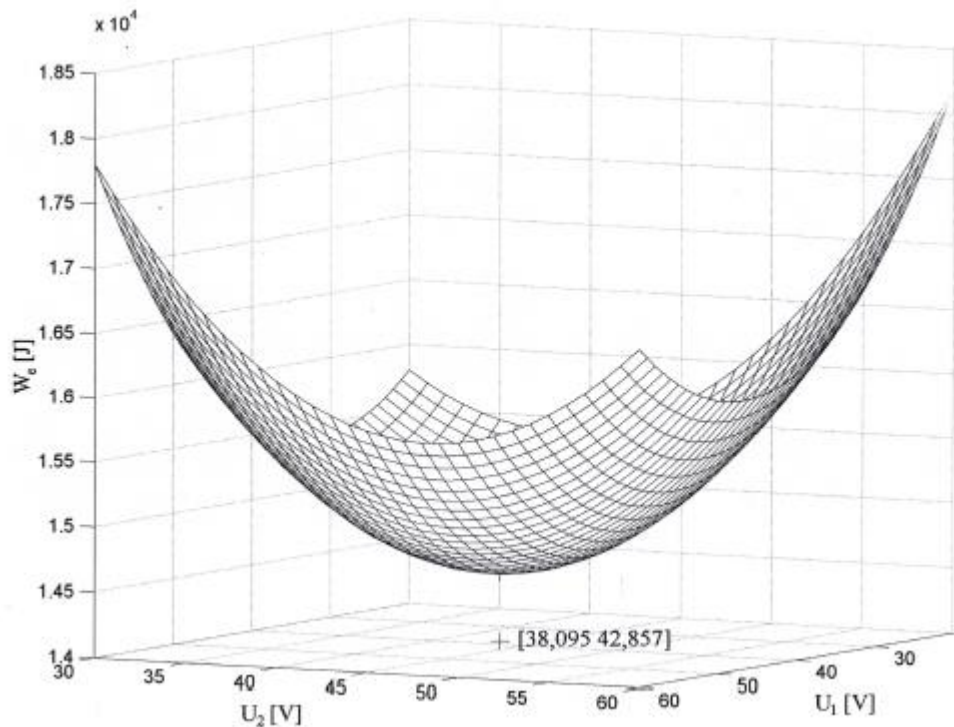

Figure 1.2, you can see the value we have here indeed expresses the minimum of this 3-D Graph, which confirms our previous conception.

At the end of this chapter, it can be said that we are still not satisfied, because it is fine that we have new a concept for the circuit but what is the use of it? The answer is that we need to build a circuit analysis step by step method if we want to apply this concept further into analysis. So, our current aim is to make a new circuit analysis technique based on the minimum distribution of energy from E.M.F throughout the circuit concept.

## Chapter 2

### Calculus of Variation

By Jamil Reza Chowdhury

#### 2.1 Introduction

Calculus of variation is a special branch of mathematical analysis which involves variations. Variations are small changes in functions and functional. A functional is a function of function. We can solve many problems of maxima and minima using the calculus of variations. In order to understand the basic idea of calculus of variation, we at first think about determining the maximum and minimum values of function,  $f(x)$  in ordinary calculus. We differentiate the function and get  $f'(x)$ . Then we set  $f'(x) = 0$ . The values of  $x$  obtained give us the points at which the slope of the function  $f(x)$  is zero. Now,  $f'(x) = 0$  is a necessary condition but not sufficient enough to find the minimum. To find the desired minimum, we have to find all the values of  $x$  such that  $f'(x) = 0$ , and then find the second derivative  $f''(x)$ . We plug in the values of  $x$  in  $f''(x)$  to get either a positive value or a negative value. A positive value gives us the value of  $x$  for which the function is minimum and a negative value gives us the value of  $x$  for which the function is maximum. But this can be done with much easiness if we consider functional that is function of function where we need to set the first derivative to zero to find the stationary points.

Now, the function ' $f(x)$ ' can be made stationary. That is, taking  $f'(x) = 0$  and finding the stationary points which consists of maximum points, minimum points and points of inflection with the horizontal axis.

So, a quantity which we can make stationary is an integral:

$$I = \int_{x_1}^{x_2} F(x, y, y') dx \quad \text{where, } y' = \frac{dy}{dx} \dots \dots \dots (2.1.1)[3]$$

Here I is a functional and  $x_1$  and  $x_2$  are lower and upper limits respectively of the integral and F is a function of x, y (a function of x) and derivative of y.

Now this 'F' can be called as a differential equation also because it contains the first derivative of y with respect to x and by solving this equation for stationary functions like  $y(x)$ , we can find  $y(x)$ , a value for which, 'I' is minimum. This approach is calculus of variation. This method is largely used in solving variation problems.

## 2.2 Calculus of Variation and Euler-Lagrange equation

We can use this concept of calculus of variation with the Euler-Lagrange equation. The following equation is the Euler equation:

$$\frac{d}{dx} \frac{\partial F}{\partial y'} - \frac{\partial F}{\partial y} = 0 \dots \dots \dots (2.2.1) \text{ (Euler-Lagrange Equation) [3]}$$

Now we can use any set of co-ordinates and separately write the independent and dependent variables and also their derivatives.

Finally applying the Euler-Lagrange equation, we can solve the resulting differential equations and we can obtain the required  $y(x)$  so that 'F' becomes

## 2.3 An example (Fermat's Principle)

A simple example of such a problem is to find the curve of shortest length connecting two points  $(x_1, y_1)$  and  $(x_2, y_2)$  in 'Cartesian Plane'.

One obvious solution is a straight line if we consider the linear geometric path and we can find the distance using Euclidian distance formula.

But if we consider curvature path, it is difficult to find obvious solutions, rather there can be many solutions of curved path.

However, Fermat's principle can be formulated by calculus of variation.

### **Fermat's Principle[5]:**

According to Fermat, the path between two points through which light travels is the path in which the time taken by light ray is minimum. [5]

Let us suppose that, the time  $T$  a point of the electromagnetic wave needs to cover a path between the points **A** and **B** is given by:

$$T = \int_{t_0}^{t_1} dt = \frac{1}{c} \int_{t_0}^{t_1} \frac{c}{v} \frac{ds}{dt} dt = \frac{1}{c} \int_A^B n ds \quad [5]$$

$c$  = speed of light in vacuum,

$ds$  = infinitesimal displacement along the ray,

$v = \frac{ds}{dt}$ , speed of light in a medium

$n = c/v$ , refractive index of that medium,  $t_0$  is the starting time (the wave front is in **A**),  $t_1$  is the arrival time at **B**.

The optical path length of a ray from a point **A** to a point **B** is defined by[5]:

$$S = \int_A^B n ds$$

which can be expressed by travel time. So,  $S = cT$ .

The optical path length is a considered a geometrical quantity because time is not counted in its calculation. An extremum in the light travel time between two points **A** and **B** can be said equivalent to the corresponding extremum of the optical path length between those two points.

The historical form that was proposed by Pierre de Fermat is incomplete.

A complete modern statement of the variational Fermat principle is that:

The optical length of the path travelled by light between two definite points, say **A** and **B**, is an extremum. The optical length is defined as the physical length multiplied by the refractive index of the material. [5]

In the context of calculus of variations this can be written as:

$$\partial S = \partial \int_A^B n ds = 0$$

Now if we choose the x-coordinate as the parameter along the path of light ray and  $y(x) = f(x)$  a function of x along the path then optical length, A can be as follows:

$A[f] = \int_{x=x_0}^{x=x_1} n(x, f(x)) \sqrt{1 + f'(x)^2} dx$ , where, the refractive index  $n(x, y)$  is material dependent.

Now by trying  $f(x) = f_0(x) + \epsilon f_1(x)$  then we get

$$\begin{aligned} \partial A[f_0, f_1] = \int_{x=x_0}^{x=x_1} & \left[ n(x, f_0) f_0'(x) f_1'(x) \frac{1}{\sqrt{1 + f_0'(x)^2}} \right. \\ & \left. + n_y(x, f_0) f_1 \sqrt{1 + f_0'(x)^2} \right] dx, \end{aligned}$$

After using integration by part of the 1<sup>st</sup> term in the brackets, we can get the Euler-Lagrange equation.

$$-\frac{d}{dx} \left[ \frac{n(x, f_0) f_0'}{\sqrt{1 + f_0'^2}} \right] + n_y(x, f_0) \sqrt{1 + f_0'^2} = 0 \dots \dots \dots [5]$$

Finally integrating this equation we can obtain the equation of paths the light rays which follow the Fermat's principle as already stated earlier.



---

## Chapter 3

# LAGRANGIAN MECHANICS

By Jamil Reza Chowdhury &

Md. Kamrul Hasan

### 3.1 Introduction

So in our previous chapter, we have discussed about the calculus of variation and used a function  $F$ . Here we will talk about “LAGRANGIAN” [4].

If kinetic energy and potential energy (K.E.-P.E.) replace function  $F$  of any system. This phenomenon is known as “LAGRANGIAN”.

This LAGRANGIAN, termed as  $L=K.E.-P.E.$  which actually is a function of some co-ordinates in a system.

Now our task is to find, the solution, so that we have to formulate the kinetic energy and potential energy equations of dependent variables in terms of independent ones. It is not the same as total energy.

### 3.2 Lagrange Equation

In this section, we shall repeat the steps of Calculus of variation discussed previously by using the LAGRANGIAN equation.

$$L=K.E.-P.E.$$

Here, K. E. = Kinetic energy,

P. E. =Potential energy

The Lagrange Equation is [4]:

$$\frac{d}{dt} \left( \frac{\delta L}{\delta \dot{x}} \right) - \frac{\partial L}{\partial x} = 0$$

Now, we can use this equation to prove Newton’s second law of motion.

Let’s consider for a system in which a body of mass,  $m$  is at a height  $h$  from the ground:

Kinetic energy of the body,  $KE = \frac{1}{2}mx^2$

Potential of the body, P.E. =  $mgx$

Hence,  $L = \frac{1}{2}mx^2 - mgx$

$$\frac{\delta L}{\delta x} = -mg$$

$$\frac{\delta L}{\delta x} = \frac{1}{2}m * 2x' - 0$$

$$= mx'$$

$$\frac{d}{dt} \left( \frac{\delta L}{\delta x'} \right) = \frac{d}{dt} (mx')$$

$$= mx''$$

$$mx'' + mg = 0$$

$$x'' + g = 0$$

$$x'' = -g$$

$$= -9.8 \text{ms}^{-2}$$

Here,  $x' = \frac{dx}{dt}$       and       $x'' = \frac{dx}{dt} * \frac{dx}{dt} = a$

so,       $mx'' = -mg$   
 $-mg = mx''$

$F = ma$  and  $\frac{d}{dt} \left( \frac{\partial L}{\partial x'} \right) - \frac{\delta L}{\delta x} = 0$  are equivalent

So, Newton's 2<sup>nd</sup> law is proved.

### 3.3 Some applications of Lagrange Equation

Now we can use this concept to prove the Coulomb's law in electrostatics:

**Coulomb's law** (using Lagrangian-mechanics)

Potential energy of an electrostatic charge,

$$W = qV$$

$$= (KQ/R) * q; \text{ here, } K = \frac{1}{4\pi\epsilon}$$

$L = \text{Kinetic Energy K.E.} - \text{Potential Energy P.E.}$

$$= \frac{1}{2}mx'^2 - KqQ/x \quad \text{here, } R = x;$$

$$\frac{dL}{dx} = + \frac{KqQ_2}{x}$$

$$= KqQ/x^2$$

$$= F$$

So,  $F = Kq_1q_2/R^2$  ; here we are replacing  $x$  with  $R$

Hence, in final step we find the Columbic force by applying the Lagrange equation.

### Simple Harmonic Motion with spring:

Potential energy in this case is the work done in stretching the spring having a spring constant= $k$

$$L = \text{K.E.} - \text{P.E.}$$

$$= \frac{1}{2}mx'^2 - \frac{1}{2}kx^2$$

$$\text{Now, } \frac{\delta}{\delta x'} \left[ \frac{1}{2}mx'^2 - \frac{1}{2}kx^2 \right] = mx' - 0$$

$$\begin{aligned} \frac{\delta L}{\delta x} &= \frac{\delta}{\delta x} \left[ \frac{1}{2}mx^2 - \frac{1}{2}kx^2 \right] \\ &= 0 - \frac{1}{2} * 2x * k \\ &= -Kx \end{aligned}$$

So, in final step we find the spring force by applying the Lagrange equation.

---

## Chapter 4

# Modifications of Euler-Lagrange Equation for Circuit Analysis

By Md. Shadman Matin

**This chapter was written under the shadow of Reference -1.**

In this chapter, we are going to modify the Euler-Lagrange equation that we learnt in the Lagrangian mechanics to apply it for circuit analysis. We are also going to talk about step by step procedure on how to apply this whenever we see a circuit.

### **4.1 The Energy Analogy:**

At first the Lagrangian has to be discussed. We took the Lagrangian to be the difference between Kinetic Energy and Potential energy of a system in mechanics. In circuits, we are going to replace the potential energy by the energy stored in the electric field of the capacitor and kinetic energy by the stored energy in the magnetic field of the inductor.

So, the first question comes right out of the box is why do we even do that? For answering this question, we have to have a feel for potential energy and kinetic energy.

Potential energy basically is something that can only be account for conservative forces. All inverse square forces like Gravity and Electric force are conservative forces. So, potential energy works more like a spring that we store something in a backpack and close it then, if you open it, it will jump right at you.

Remember the circuit of capacitor charging and discharging. A capacitor is connected with a resistor and a battery in series. When the charged voltage equal to the E.M.F, the current was zero. You can say the energy delivery is done. Now, as soon as the E.M.F is disconnected from the circuit, there are no element present to 'pressurize' the charging, so the energy reflects back in the opposite direction in the form of current when the capacitor discharging.

This whole concept of capacitor charging and discharging resembles with contracting a spring (charging) and letting it go (discharging). So, obviously this capacitor energy can be compared with potential energy.

Now, this kinetic energy is involved with object in motion. Something that moves possess kinetic energy. We know from faraday's laws of induction that in an inductor if the current changes in value, an EMF is induced to eliminate that change in current. So, think of a circuit having constant current (compare this with an object with constant velocity having constant

kinetic energy). Suddenly the current changes and an EMF is induced. As there is EMF, we say there is an energy. But from where we got this energy? This was stored in the magnetic field of the inductor and it came out as the induced EMF when we needed it. So, this comparison makes it clear that kinetic energy corresponds to the energy in the magnetic field of the inductor.

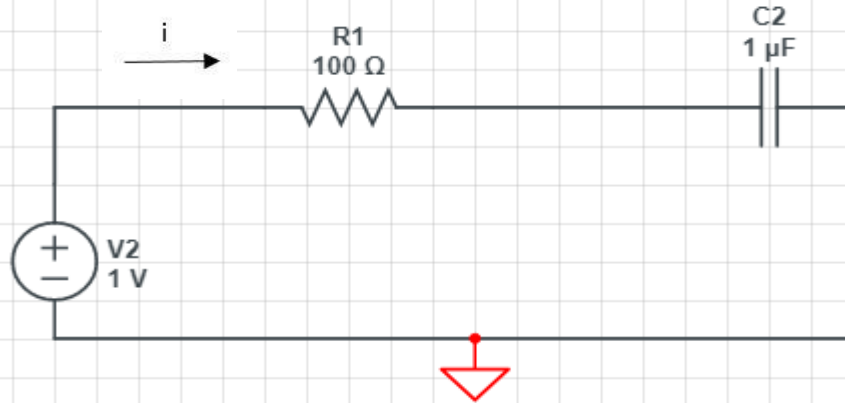

Figure 4.1, configuration for charging a capacitor.

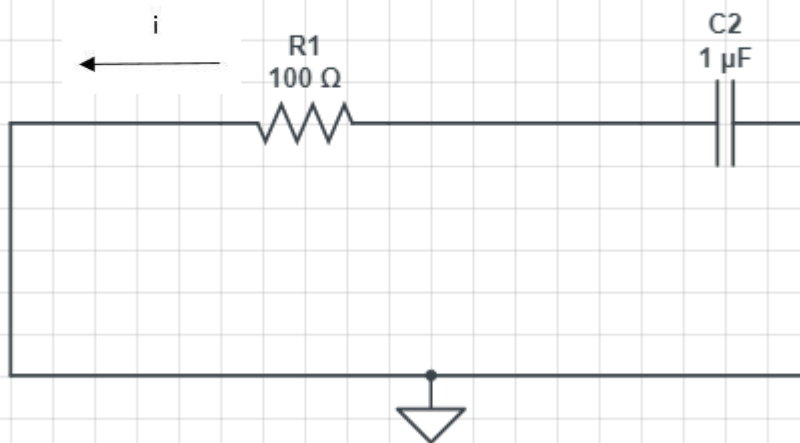

Figure 4.2, configuration when the initially charged capacitor in figure 4.1 starts to discharge and current flows in the opposite direction.

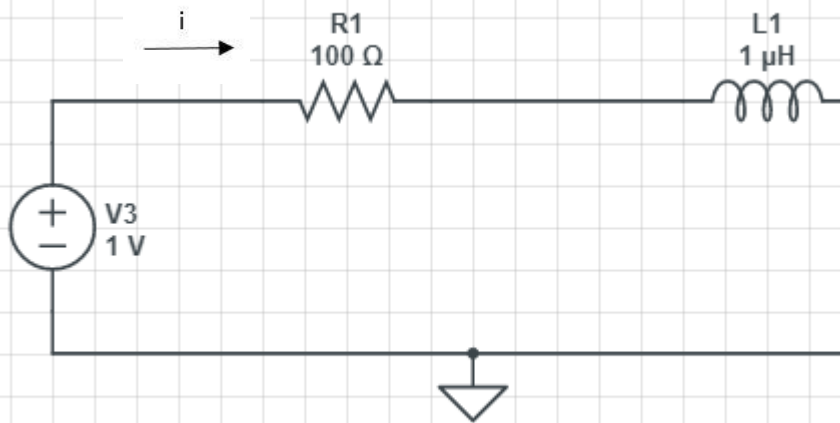

Figure 4.3, after switching on the circuit, after some transient current, a steady state current is achieved in the circuit.

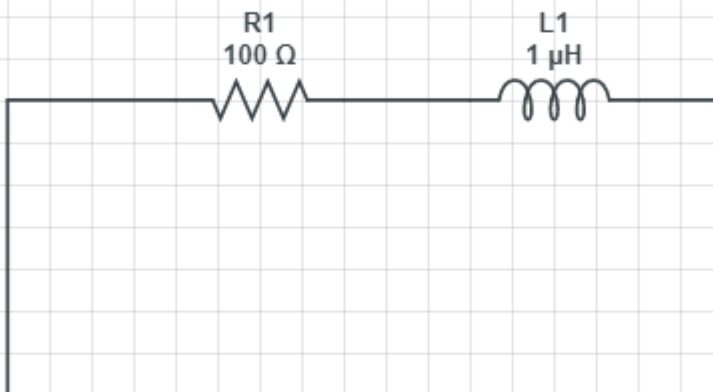

Figure 4.4, after taking off the voltage source, current tries to dissipate but to eliminate this change, inductor rises EMF to energize the fading current.

#### **4.2 New factors for the modified Euler Lagrange equation:**

After learning the energy analogy, we now know how to formulate the Lagrangian for circuit.

So, Lagrangian = (Energy of Inductor) - (Energy of Capacitor)

$$\Rightarrow L = (1/2)(\text{inductance})(\text{current})^2 + (1/2)(\text{charge})^2(1/\text{capacitance})$$

So, problem with Lagrangian is done.

Another problem is with generalized co-ordinates. In Lagrangian Mechanics, the generalized co-ordinates are position co-ordinates i.e.  $x$ ,  $y$ ,  $z$  which are ultimately function of time. We also have to keep in mind that, Lagrangian in mechanics is function of generalized co-ordinates. So this gives us a clue that the generalized co-ordinates for circuits will also be included in Lagrangian. So, it is very clear that, the co-ordinate is charge and its derivative, current. Now, next problem is to find the independent generalized co-ordinates. We can simply use KCL to find this out.

Suppose,  $(\text{current1}) = (\text{current2}) + (\text{current3})$ ;

So, I can say that, there are two independent currents here, say,  $\text{current1}$  and  $\text{current2}$  are independent and  $\text{current3}$  can be written as a combination of these two independent currents. This will be very easy to grasp when we are solving problems by this methods.

Now, we have learnt about the independent charge and current.

One main difference about the normal lagrangian mechanics with the circuit version lagrangian formulation is that, there is constraint in the circuit, simply put there is always an EMF to energize the independent current associated with it. So, while formulating anything with circuits we have to take account for these energizing constraint EMF. Check out figure 4.5.

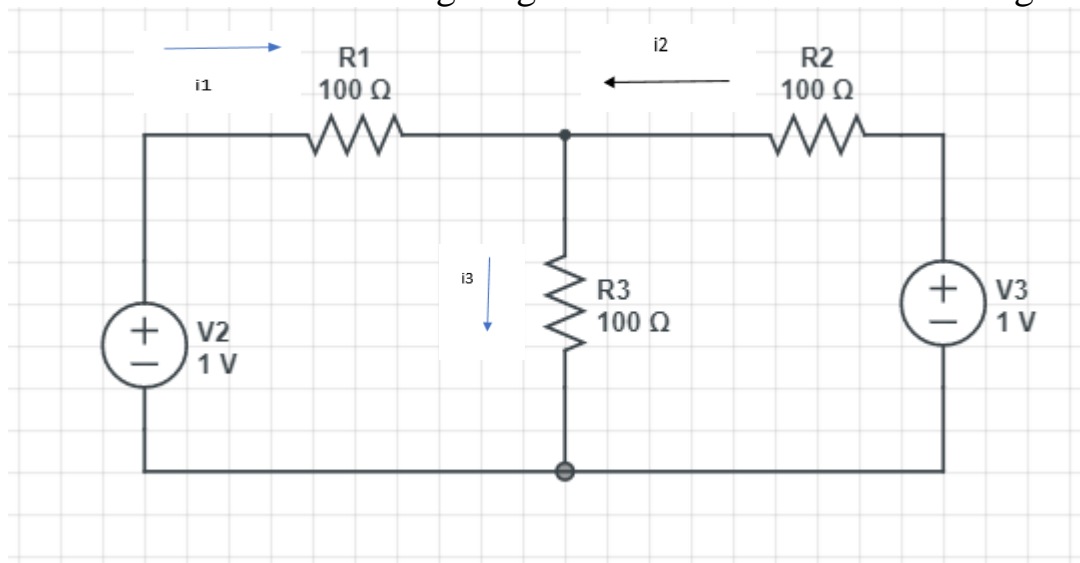
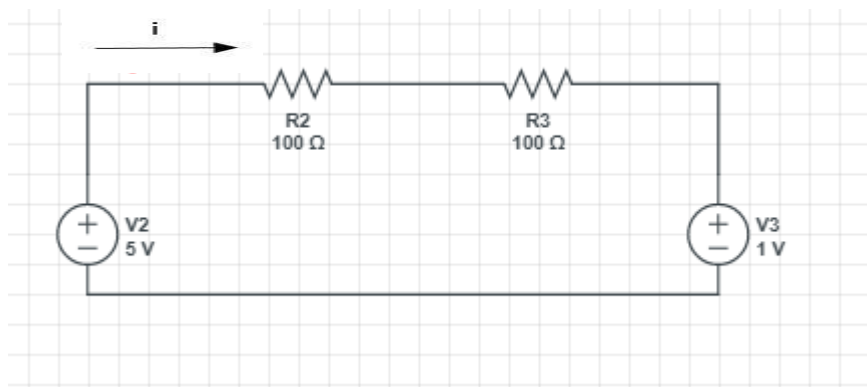

Figure 4.5, the constraint for  $i_1$  is  $+V_2$  because it is energizing the current and the constraint for  $i_3$  is  $+V_3$ , because it is working against the current.

Also notice that in figure 4.5, the constraints are directly involved with the current. If you are thinking that for  $i_3$  the constraint will be  $V_1 + V_2$ , then , you are certainly wrong, because no direct EMF is connected to it.

But yes, if this was a single loop circuit, then of course we will take the net EMF that is energizing the current. Check out figure 4.6



Figure, 4.6. The net constraint for current  $i$  is  $V_2 - V_3$ .

The final factor that we have to account for in the circuit is the dissipating element resistor. We have to form the Rayleigh dissipating function to account this.

Rayleigh Dissipating Function,

$$R = \sum_{i=1}^n ((i - \text{th resistance})(\text{current through that resistor})^2)$$

Where suppose that there are 'n' numbers of resistors are there in the circuit.

To sum up everything, let us see what changes we did,

1. Capacitor's energy is equivalent to potential energy.
2. Inductor's energy is equivalent to kinetic energy.
3. Rayleigh dissipation function accounts for the joule heating in resistors.
4. We have to find the independent currents in the circuit by KCL.
5. Each current if connected directly to any EMF, will be subjected to constraint force by that EMF. If there are no direct EMF connected to that independent current, the constraint is zero.

Now, we are ready to face the modified equation,

$$\frac{d}{dt} \left( \frac{\partial L}{\partial q'_j} \right) - \frac{\partial L}{\partial q_j} + \frac{\partial R}{\partial q'_j} = Q_j, \quad j=1, \dots, s$$

.....equation(4.1)

$L$  = Lagrangian,

$Q_j$  is the constraint EMF for  $j$ -th independent current,

There are 's' independent currents,

$q'_j$  is the independent current or the derivative of the independent charge,

$q_j$  is the independent charge,

$R$  is Rayleigh dissipation function.



Now, everything is ready, let's talk about the step by step procedure for analyzing circuit in this new procedure.

1. Find the resistors and draw a current passing through them.
2. Form the Rayleigh Dissipation Function with these resistors and the currents passing through them.
3. Use the KCL to find independent currents and edit the Rayleigh Dissipation Function in terms of the independent currents only.
4. Form the Lagrangian. Be sure to use the formula for capacitor in which the charge in the capacitor is included.
5. Count the independent currents and write the corresponding lagrange-euler equation accordingly. Be sure to include the constraint on the right side properly.
6. Solve the each resulting differential equation to get each independent current as a function of time.

# Chapter 5

## Series RL, RC, RLC Circuit Analysis by Lagrangian Formulation

By Md. Shadman Matin

In this chapter, we will apply the modified euler-lagrange equation for series RC, RL, RLC circuit. We will solve each one by the conventional way and then show that the new formulation gives birth to the same equation proving that the new theory is correct.

### 5.1 Series RC Circuit:

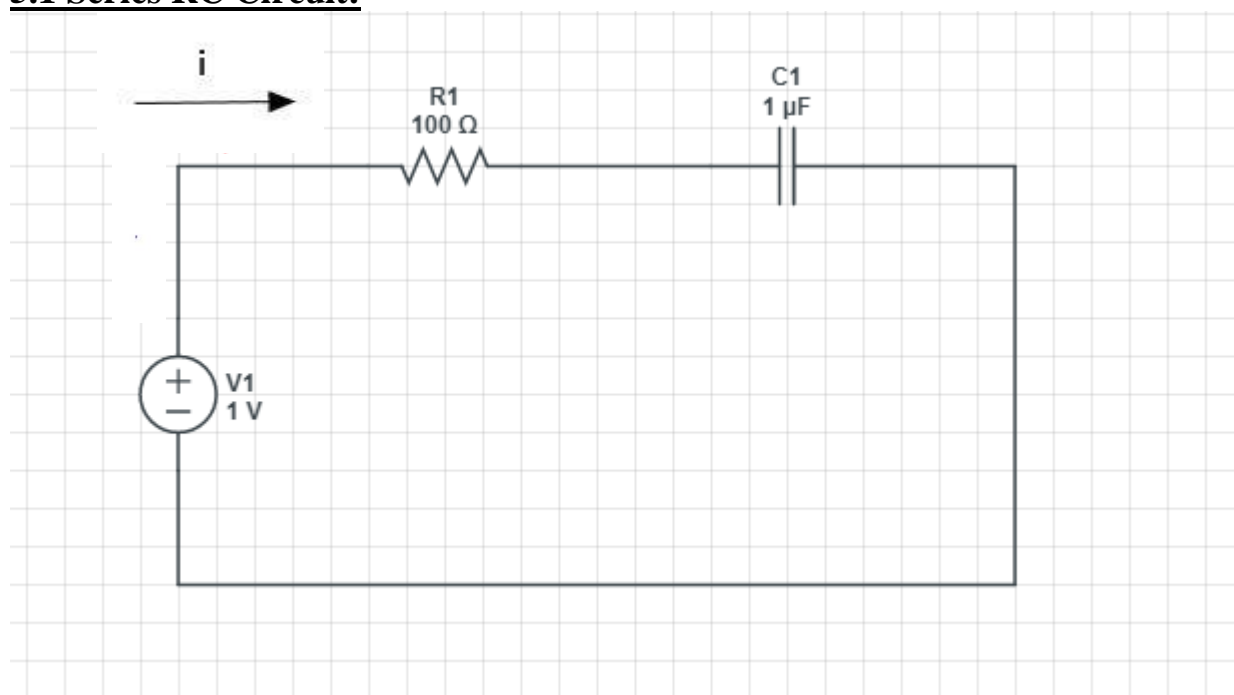

Figure 5.1, series RC configuration

Let's first solve this in the conventional way.

Applying KVL into the only loops results in,

$$V1 = i (R1) + (q1/C1)$$

We will now apply the new method,

$$\text{Lagrangian, } L = (-1)(0.5)(q1)^2 (1/C1)$$

$$\text{Rayleigh dissipative function, } R = (0.5) (R1) (i1)^2$$

Applying all these to the modified Euler-Lagrange equation 4.1, we get,

$$0 - (-1)(q1/C1) + i(R1) = V1$$

$$\text{Or, } q1/c1 + i(R1) = V1$$

Which is exactly the result we get from the conventional way. We should keep in mind that here, the constraint EMF for  $i$  is  $V1$  which energizes it.

## 5.2 Series RL circuit:

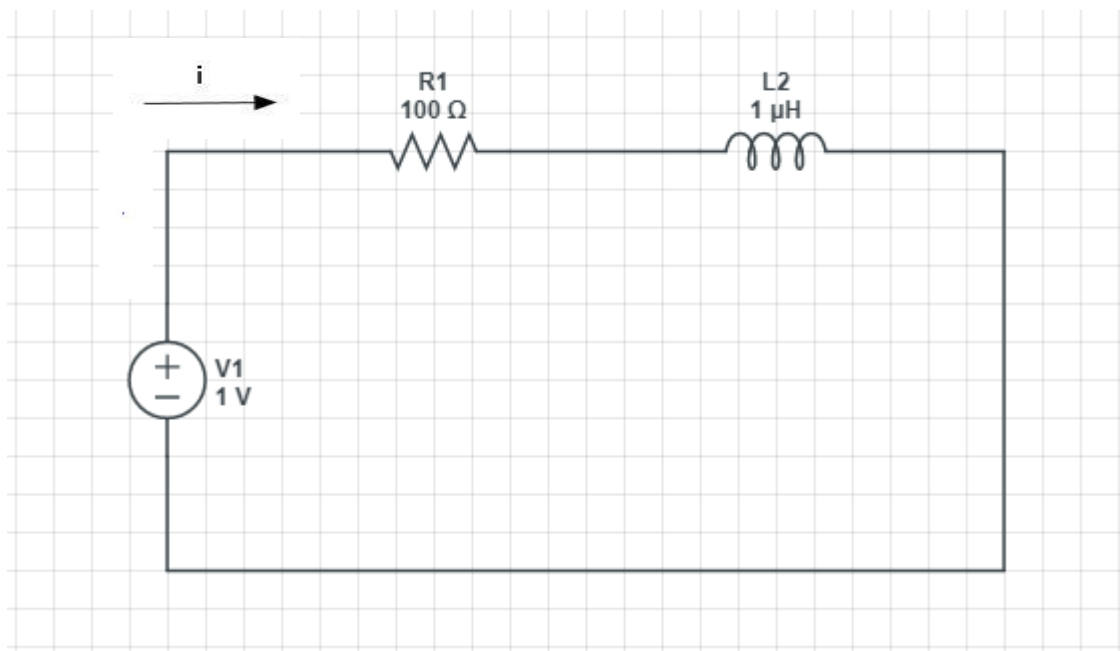

Figure 5.2, series RL configuration

We'll solve this circuit in the laplace domain conventionally.

Impedance of the inductor is  $sL2$

Impedance of the resistor is  $R1$

Applying by KVL in the only loop we get,

$$i(s)[R1 + sL2] = V1(s)$$

Now, we'll see whether our new approach gives us the same result or not.

Lagrangian,  $L = (0.5)(L2)(i)^2$ ;

Rayleigh dissipation function,  $R = (0.5)(R1)(i)^2$ ;

Applying these on modified euler-lagrange equation, 4.1 we get,

$$L1 (di/dt) + i(R1) = V1$$

This differential equation can be solved in the laplace domain.

So, we get,

$$(L1)(s)(i(s)) + i(s)(R1) = V1(s)$$

$$\text{Or, } V1(s) = i(s)[R1 + sL2]$$

So, we get the same equation we got in the conventional process.

### 5.3 Series RLC Circuit:

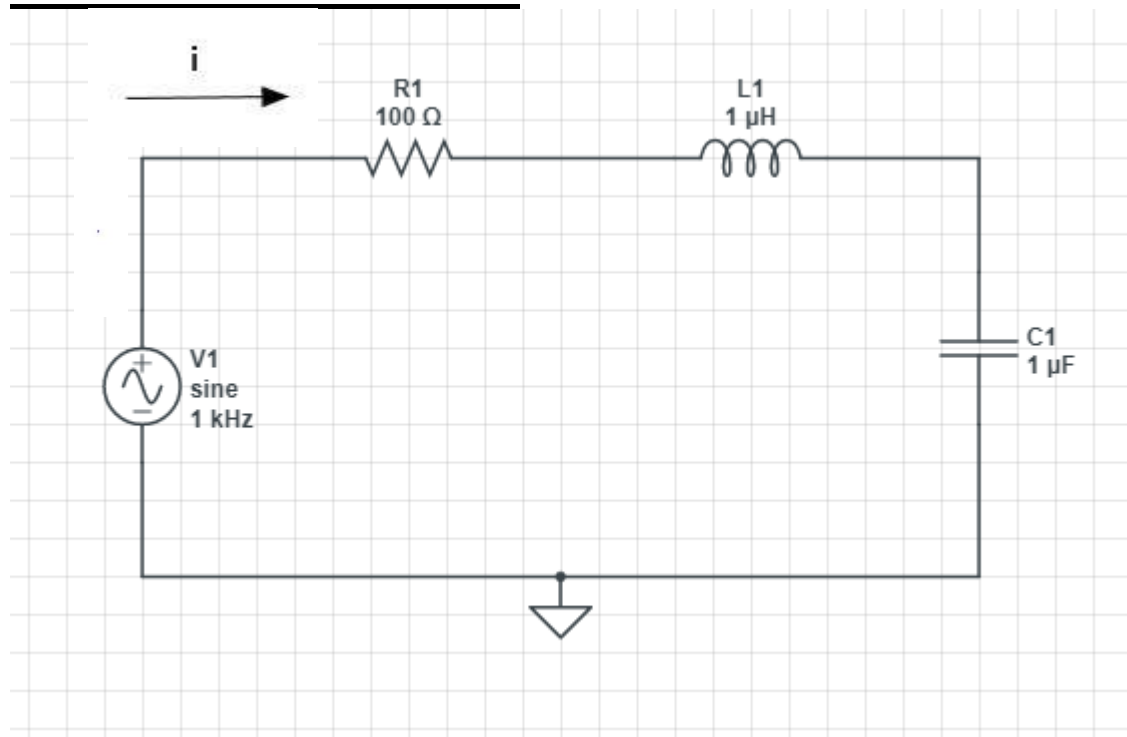

Figure 5.3, series RLC configuration

This is the first AC circuit that we are dealing with. Nothing changes except that the constraint EMF function is now a sinusoid. So, let's first apply the conventional method first.

Applying KVL in the only loop results in,

$$V1 = (\text{Voltage drop across resistor}) + (\text{Voltage drop across inductor}) + (\text{Voltage drop across capacitor})$$

$$\text{Or, } V1 = i(R1) + (L1)(di/dt) + q/(C1)$$

Now, let's apply the new method,

Lagrangian,  $L = (0.5)(L1)(i)^2 - (0.5)(q)^2(1/C1)$

Rayleigh Dissipation Function,  $R = (0.5)(R1)(i)^2$

The constraint for 'i' will be  $V1$ , which is a sinusoid in this case.

So, applying everything in the modified euler-lagrange equation, 4.1, we have,

$$(L1)(di/dt) + (q/C1) + (i)(R1) = V1$$

Which is the same equation we got in the conventional way.

So, these all examples prove that this lagrangian formulation is indeed an alternative way to analyze circuits. Analyzing circuit meant here to find out the branch current because, from that other quantities like initial charge of a capacitor, initial current of an inductor, voltage drop across resistor, capacitor or inductor can be determined easily just by using the relevant formula.

---

# Chapter 6

## Conclusions and Visions

By Md. Shadman Matin

In this final chapter, we will talk about the summary of this new technique and some works that are possible with it in the future.

When we are learning circuit analysis, we only don't need KVL and KCL, but also many other tools like many circuit theorems, nodal analysis, mesh analysis etc. When anyone is given a circuit and told to find the branch currents or nodal voltages or say the initial charge of a capacitor, that person has to rely on his/her experience on circuit analysis and practice to determine which approach will give him/her the easiest way.

But, we can now see that, no matter how complicated the circuit may be, you just have to apply this only one technique. Now you might argue that, this technique is rather very tedious and mathematically comparably complex because at least it involves solving the differential equations.

Now, it can be argued with two counter benefits. One is that, if you have the right mathematical model, you can use computer software like MATHEMATICA, MAPLE and MATLAB to solve these math problems for you. All you need is a correct mathematical modelling. Rest is the job for the computer.

Another one is, all you have to learn is a single approach. And this approach is quite soothing, because it is a fundamental understanding of the circuits.

As this approach is fundamental in nature and there is also another formulation of classical mechanics called Hamiltonian mechanics, so it is so much clear that, there must be another formulation for circuit analysis based of Hamiltonian mechanics. So, we have not done that yet.

Then, as it is been said before that, computers can be given the task to solve if the circuit is very complicated, new softwares or at least

functions in softwares like MATLAB, MATHEMATICA can be built according to this new algorithm.

So, at the end, it is evident that, classical mechanics and circuit analysis runs on the same basis and that is energy minimization throughout a system. And no matter how many formulations we make, this principle will be always valid.

# REFERENCES

- [1] “Hamilton’s Principle and Electric Circuit Theory”, D.Mayer  
AEEE-2006-5-3-185-mayer.pdf
- [2] Physics-Volume 2, Resnick, Halliday, Krane.
- [3] Mathematical Methods for Physical Science, Mary L. Boas
- [4] Classical Mechanics, John R Taylor
- [5] [https://en.wikipedia.org/wiki/Calculus\\_of\\_variations](https://en.wikipedia.org/wiki/Calculus_of_variations)  
[https://en.wikipedia.org/wiki/Functional\\_\(mathematics\)](https://en.wikipedia.org/wiki/Functional_(mathematics))
- [6] Classical Mechanics, Goldstein.
- [7] Fundamentals of Electric Circuits, Alexander-Sadiku (Fourth Edition)