



ISLAMIC UNIVERSITY OF TECHNOLOGY
ORGANIZATION OF ISLAMIC COOPERATION



EFFECT OF RAKE ANGLE & RELIEF ANGLE IN CHIP FORMATION DURING TURNING OPERATION

PREPARED BY-

Tanvir Ahmed(141425)

Eftekharul Hoque Anik (141427)

Fahim Ajmal Rythm (141428)

SUPERVISED BY :

Prof. Dr. Md. Anayet Ullah Patwari

Professor, Department of Mechanical and Chemical Engineering(MCE)

Department of Mechanical and Chemical Engineering(MCE)

CERTIFICATE OF RESEARCH

The thesis title “**EFFECT OF RAKE ANGLE & RELIEF ANGLE IN CHIP FORMATION DURING TURNING OPERATION**” submitted by **TANVIR AHMED(141425),EFTEKHARUL HAQUE ANIK(141427),FAHIM AJMAL RYTHM(141428)** has been accepted as satisfactory in partial fulfillment of the requirement for the Degree of Bachelor of Science in Mechanical & Chemical Engineering on November,2018.

Supervisor-

PROF. DR. MD. ANAYET ULLAH PATWARI

Professor, Department of Mechanical and Chemical Engineering (MCE)

ISLAMIC UNIVERSITY OF TECHNOLOGY (IUT)

DECLARATION

THIS IS TO CERTIFY THAT THE WORK PRESENTED IN THIS THESIS IS AN OUTCOME OF THE ANALYSIS, SIMULATION & RESEARCH BY THE AUTHOR THEMSELVES UNDER THE WATCHFUL SUPERVISION OF PROF. DR. MD. ANAYET ULLAH PATWARI.

AUTHORS:

TANVIR AHMED(141425)

EFTEKHARUL HAQUE ANIK(141427)

FAHIM AJMAL RYTHM(141428)

PROF. DR. MD. ANAYET ULLAH PATWARI
(Project supervisor)

ACKNOWLEDGEMENTS

We would like to express our deepest appreciation to our respectable supervisor **PROF. DR. MD. ANAYET ULLAH PATWARI** for his support, guidance, care, tutelage, motivation and patience throughout the research period. We appreciate his talent and the encouragement which he provided us throughout this academic year. All credit goes to him who made our project successful. Without his help and contribution our work would not have been able to come to this stage of completeness and fulfilment of our bachelor degree. Apart from him we would like to thank each and every faculties of our **Department of Mechanical & Chemical Engineering (MCE)** for their knowledge, assistance, motivation and care throughout the study period. We also place on record, our sense of gratitude to one and all, who directly or indirectly, have lent their hands in successful completion of this project work. Finally we want to express our gratitude to **ALLAH, THE ALMIGHTY**.

Contents

- **CERTIFICATE OF RESEARCH.....2**
- **DECLARATION.....3**
- **ACKNOWLEDGEMENTS.....4**
- **ABSTRACT.....7**
- **Chapter 1: Introduction**
 - 1.1 Importance of the study.....11**
 - 1.2 Methodology..... 15**
 - 1.3 Metal Cutting.....16**
 - 1.3.1 Brief history of metal cutting.....17**
 - 1.4 Turning Operation.....20**
 - 1.4.1 Turning.....22**
 - 1.4.1.1 Tapered turning.....22**
 - 1.4.1.2 Spherical generation22**
 - 1.4.1.3 Hard turning22**
 - 1.4.2 Facing23**
 - 1.4.3 Parting.....23**
 - 1.4.4 Grooving.....24**
 - 1.4.4.1 Boring.....24**
 - 1.4.4.2 Drilling24**
 - 1.4.4.3 Knurling.....24**
 - 1.4.4.4 Reaming.....25**
 - 1.4.4.5 Threading26**
 - 1.4.4.6 Polygonal turning.....26**
 - 1.4.5 Process Cycle.....26**
 - 1.4.6 Cutting parameters27**
 - 1.4.7 Tooling..... 27**

1.5 Chip morphology.....	28
1.6 Chip Classification.....	29
1.7 Mechanisms of Chip Formation:.....	31
1.8 Chip reduction coefficient or cutting ratio.....	40
1.9 Chip Thickness Measurement Technique.....	44
• <u>Chapter 2 :LITERATURE REVIEW.</u>	
2.1 The Review of Major Research on Chip Formation.....	46
2.1.1 Modeling of chip formation.....	49
2.1.2 Chip curling mechanisms.....	53
2.1.2.1 Chip up-curling.....	53
2.1.2.2 Chip side-curling.....	53
2.1.3 Chip breaking Modeling.....	54
2.2 The further review of chip control research.....	57
• <u>Chapter 3:Methodology and Experimental investigation</u>	
3.1 Numerical Modeling.....	66
3.2 Experimental setup.....	67
3.3 EXPERIMENTAL RESULT.....	68
3.3.1 Aluminium(Tempersture).....	69
3.3.2 Cast Iron(Tempersture).....	74
3.3.3 Stainless Steel(Tempersture).....	75
3.4 Chip thickness.....	76
3.4.1 Aluminium.....	77
3.4.2 Cast Iron.....	79
3.4.3 Stainless steel.....	80
3.4 Result analysis.....	82
• <u>Chapter 4: REFERENCES</u>	85
• <u>Chapter 5:Appendixes</u>	87
5.1 Simulations.....	88

Abstract

The simulation of various machining processes is a matter of interest in active research for over two decades. This study develops a combined simulation based and experimental approach to find the effect of rake Angle & relief Angle in chip formation during turning operation to get deeper insight into chip formation mechanism of three different types of materials-Aluminium(Al-6061),Cast Iron(J431 G1800) and Stainless Steel(304L). In this paper, the morphology of chip formation during turning operation of Aluminium,Cast Iron and Stainless Steel are investigated based on simulation done by software “**AdvantEdge**”. In this research work optimum rake angle and relief angle of Aluminium(Al-6061),Cast Iron(J431 G1800) and Stainless Steel(304L) are being used for experimental investigation and different range of chip thickness in different zone are observed.

Keywords-Turning operation, Simulation, Chip thickness.

1 Introduction

Chapter 1: Introduction

Turning is a form of machining, a material removal process, which is used to create rotational parts by cutting away unwanted material. In this process cutting tool, typically a non-rotary tool bit, describes a helix toolpath by moving more or less linearly while the workpiece rotates. The tool's axes of movement may be literally a straight line, or they may be along some set of curves or angles, but they are essentially linear. Usually the term "turning" is reserved for the generation of *external* surfaces by this cutting action, whereas this same essential cutting action when applied to *internal* surfaces (that is, holes, of one kind or another) is called "boring". Thus the phrase "turning and boring" categorizes the larger family

of (essentially similar) processes known as lathing. The cutting of faces on the workpiece (that is, surfaces perpendicular to its rotating axis), whether with a turning or boring tool, is called "facing", and may be lumped into either category as a subset. Turning can be done manually, in a traditional form of lathe, which frequently requires continuous supervision by the operator, or by using an automated lathe which does not. Today the most common type of such automation is computer numerical control, better known as CNC. (CNC is also commonly used with many other types of machining besides turning.) When turning, a piece of relatively rigid material (such as wood, metal, plastic, or stone) is rotated and a cutting tool is traversed along 1, 2, or 3 axes of motion to produce precise diameters and depths. Turning can be either on the outside of the cylinder or on the inside (also known as boring) to produce tubular components to various geometries. Although now quite rare, early lathes could even be used to produce complex geometric figures, even the platonic solid; although since the advent of CNC it has become unusual to use non-computerized toolpath control for this purpose. The turning process requires a turning machine or lathe, workpiece, fixture, and cutting tool. The workpiece is a piece of pre-shaped material that is secured to the fixture, which itself is attached to the turning machine, and allowed to rotate at high speeds. The cutter is typically a single-point cutting tool that is also secured in the machine, although some operations make use of multi-point tools. The cutting tool feeds into the rotating workpiece and cuts away material in the form of small chips to create the desired shape.

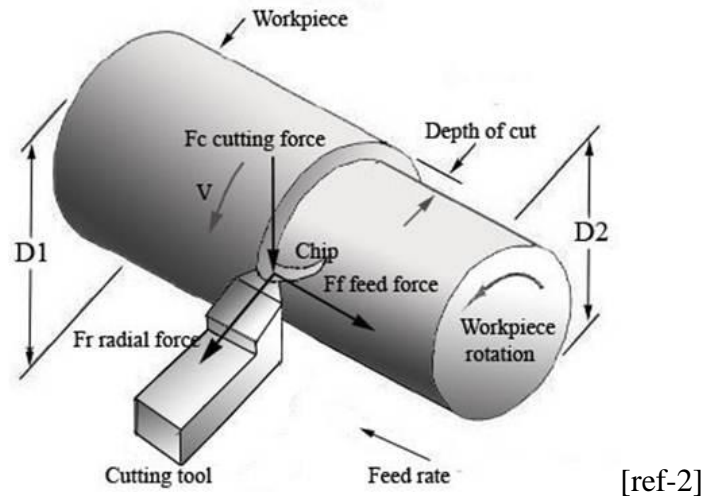

AdvantEdge is the premier Finite Element Analysis (FEA) product used to understand the metal cutting process. It features a full suite for analysis including chip formation, temperature and stresses and forces on the tool and workpiece. The software has a validation process and materials models built into the program specifically for the metal cutting, which allows for confident decision making without physical testing.

1.1 Importance of the study

To boundary value problems for partial differential equations. It is also referred to as finite element analysis (FEA). It subdivides a large problem into smaller, simpler parts that are called finite elements. The simple equations that model these finite elements are then assembled into a larger system of equations that models the entire problem. FEA then uses variation methods from the calculus of variations to approximate a solution by minimizing an associated error function.

In the recent past, Finite Element (FE) modeling has emerged as one of the most effective tools that could substitute the conventional time consuming and expensive experimental tests to a great extent.

With the expanding use of automation in machining technology, the modern manufacturing is toward achieving high productivity without close human supervision. It requires reliable machining process. As a result an urgent need for the unmanned automated machining has arisen to integrate manufacturing, product/process design,

life-cycle considerations. Such is needed to develop a Computer Integrated Manufacturing (CIM) system. The Computer Integrated Manufacturing (CIM) is recognised as an effective platform for increasing manufacturing competitiveness. It includes the Computer Aided Manufacturing (CAM), Computer Aided Process Planning (CAPP) and Computer Aided Quality Control Systems (CAQC). The advances in CAPP and CIM leading towards unmanned system inevitably require a Computer Integrated Predictive (CIP) System for total chip control in metal cutting process as highlighted in Fig. 1

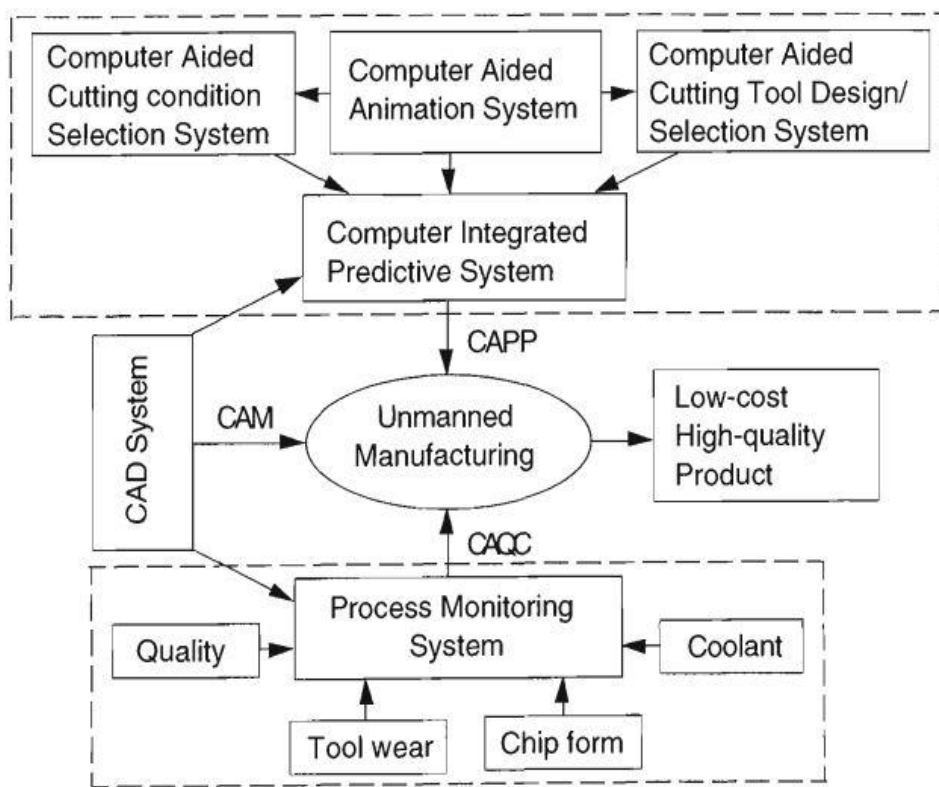

Fig.1.10 Advanced Computer Integrated Manufacturing System [ref-4]

The Computer Aided Animation System (CAA) is an essential key for achieving CIP. The basis of the system is the development of a method for characterising the cutting tool and workpiece materials response to the conditions created during metal cutting process, such as turning, milling and drilling. Since the present knowledge of chip control is inadequate to describe quantitatively the processes of chip flow, chip curl and chip breaking, it becomes very

difficult to predict chip forming behaviour in the actual machining process with a high degree of accuracy. This is attributed to the extremely complex nature of chip formation patterns with varying tool configuration/geometry features and their interactions with work materials under various cutting conditions. Indeed, the present knowledge of chip control is found to be segmented and scattered; and currently available machinability database systems have not incorporated the chip control factor either. Individual factors influencing chip breakability, such as tool chip breaker configurations, tool geometry, work material properties and cutting conditions, have not been fully studied to provide a basis for optimal chip breaking. Although several hundred types of cutting tools, with different toolface configurations involving various chip groove profiles, obstruction lumps, wavy cutting edges and curved rake faces, have become commercially available. As stated previously most of these cutting tools are designed on the basis of the traditional "try and see" experimental methods. Thus it is apparent that a more scientific methodology is required to avoid these time-consuming and less-accurate methods. Therefore it has been recognised that there is a great need to develop the theoretical models of metal cutting process for the Computer Aided Animation System. It is expected that these theories would enable predictions of chip flow, chip curl, chip forms, chip breakability, stresses, strain and cutting forces, etc. from the basic work material properties, cutting conditions and cutting tool geometry. Almost all of the major metal cutting theories known to the world today are based on the orthogonal cutting process producing a continuous chip. While it is fully acknowledged that these theories have in the past laid a strong foundation in our understanding of the process of metal cutting, it is also to be recognized that recent advances in automated machining systems now inevitably require the modelling, predicting, and monitoring of the process of chip breaking for which the traditional theories on chip formation need to be extended in three ways: (1) to include the dynamics of the chip formation process; (2) to develop three-dimensional chip formation models; and (3) to include chip breakage (van Luttervelt, 1977). To accomplish these major objectives it is essential to understand the mechanisms and mechanics of chip flow, chip curling and chip breakage. The need for developing the theoretical models to address the problems

concerning chip control has been highlighted based on the results of an extensive survey on chip control covering over 550 published papers (Jawahir and van Luttervelt 1993).

It is noticed, however, that much of the knowledge, many theories and practical techniques about machining have not been fully utilised in assessing the chip control effects. Therefore it is imperative to develop a Computer Animation System which integrates them with the theoretical models developed in this thesis to achieve total control.

It should be recalled that the goal of metal cutting research is to establish the theory or analytical system which enables machining performance prediction without any cutting experiment.

Hence in this thesis, the main objective of the research will be concentrated towards development of the theoretical models of the 3-D chip curling to analyse the geometry and mechanics of curled chips, and to develop a computer animation system to simulate the process of chip curling in 3-D metal cutting. Consequently, in terms of ultimate application, the work described in this thesis is devoted to the development of an effective theoretical means for chip control in automated machining systems. The theoretical models will describe the curling process of 3-D chip curling, including the geometry model, mechanics model, animation model. This research focuses on the following four aspects:

- (a) Building of a new systematic comprehensive 3-D chip curling formation process model. This model subsequently forms the basis for further theoretical modelling of the geometry and mechanics of 3-D chip curling in metal cutting.
- (b) Development of a geometry model of 3-D curling chip to predict the chip forms/shapes efficiently according to the proposed 3-D chip curling developing process proposed.
- (c) Development of the mechanics models of 3-D curling chip to analyse the force system and bending moment and torque acting on the chip body and so predict the chip deformation and subsequent breakage.
- (d) Development of a computer animation system to animate the 3-D chip curling

form and the cutting process performance, including the animation model and the animation software.

1.2 Methodology

In cutting and abrasive processes, the cutting edge penetrates into the work piece material, which is thus plastically deformed and slides off along the rake face of the cutting edge. This is called chip formation. The processes in chip formation can be examined within the orthogonal plane, because essential parts of the material flow take place within this plane. We can assume that the deformation is two-dimensional. The two-dimensional deformation is only disturbed at the edges of the cross section of the un-deformed chip, at the free surface and in front of the cutting-edge corner, as there is material flow at an angle towards the orthogonal plane, which is caused by linkage to the un-deformed material by the free surface respectively. Depending on the deformation behavior of the work piece material, there are different mechanisms of chip formation with either continuous or discontinuous chip flow. Chip formation methodology will be discussed throughout the introduction.

The form of the chips is an important index of machining because it directly or indirectly indicates:

- Nature and behavior of the work material under machining condition
- Specific energy requirement (amount of energy required to remove unit volume of work material) in machining work
- Nature and degree of interaction at the chip-tool interfaces. The form of machined chips depends mainly upon:
 - Work material
 - Material and geometry of the cutting tool
 - Levels of cutting velocity and feed and also to some extent on depth of cut
 - Machining environment or cutting fluid that affects temperature and friction at the chiptool and work-tool interfaces.

Knowledge of basic mechanism(s) of chip formation helps to understand the characteristics of chips and to attain favorable chip forms.

1.3 Metal Cutting

Metal cutting is one of the most important methods of removing unwanted material in the production of mechanical components. This metal removing treatment involves numerous fields the description of which demands application of fundamentals of physics, chemistry, materials behaviour, and the engineering sciences of heat transfer, solid mechanics, and surface science (tribology). It would serve no useful purpose to attempt a precise definition of metal cutting. Here the term is intended to include operations in which a thin layer of metal, the chip or swarf, is removed by a wedge-shaped tool from a larger body. There is no hard and fast line separating chip-forming operations from others such as the sheet metal shearing, the hole punching or the bar cropping into lengths. These also can be considered as metal cutting, but the action of the tools and the process of separation two parts are so different from those encountered in chip-forming operations that the subject requires a different treatment and these operations are not considered here. There is a great similarity between the operations of cutting and grinding. Our ancestors ground stone tools before metals were discovered and later used the same process for sharpening metal tools and weapons. The grinding wheel does much the same job as the file, which can be classified as a cutting tool, but has a much larger number of cutting edges, randomly shaped and oriented. Each edge removes a much smaller fragment of metal than is normal in cutting, and it is largely because of this difference in size that conclusions drawn from investigations into metal cutting must be applied with reservations to the operation of grinding. In the engineering industry, the term machining is used to cover chip-forming operations, as defined in many dictionaries. Most machining is carried out to shape metals and alloys, but the lathe was first used to turn wood and bone, and today many plastic products also are machined. The term metal cutting is used here because research has shown certain characteristic features of the metal behaviour during cutting which dominate the process. Hence without further work, it is not possible to extend the principles described here to embrace the cutting of other materials.

1.3.1 Brief history of metal cutting

Before the middle of the 18th century the main material used in engineering structures was wood. The lathe and a few other machine tools existed, mostly constructed in wood and most commonly used for shaping wooden parts. The boring of cannons and the production of metal screws and small instrument parts were the exceptions. It was the steam engine, with its requirement of large metal cylinders and other parts of unprecedented dimensional accuracy, which led to the first major developments in metal cutting. The materials of which the first steam engines were constructed were not very difficult to machine. Grey cast iron, wrought iron, brass and bronze were readily cut using hardened carbon steel tools. The methods of heat treatment of tool steel had been evolved by centuries of craftsmen, and reasonably reliable tools were available, although rapid failure of the tools could be avoided only by cutting very slowly. At the inception of the steam engine, no machine tool industry existed. Hence the whole of this industry is the product of the last two hundred years. Notably the century from 1760 to 1860 saw the establishment of enterprises devoted to the production of machine tools. Maudslay, Whitworth, and Eli Whitney, among many other great engineers, devoted their lives to perfecting the basic types of machine tools required for generating, in metallic components, the cylindrical and flat surfaces, threads, grooves, slots and holes of many shapes required by the developing industries.

The lathe, the planer, the shaper, the milling machine, drilling machines and power saws were all developed into rigid machines capable, in the hands of good craftsmen, turning out large numbers of very accurate parts and structures of sizes and shapes that had never before been contemplated. By 1860 the basic problems of how to produce the necessary shapes in the existing materials had largely been solved. There had been little change in the materials which had to be machined - cast iron, wrought iron and a few copper based alloys. High carbon tool steel, hardened and tempered by the blacksmith, still had to answer all the tooling requirements. The quality and consistency of tool steels had been greatly improved by a century of experience with the crucible steel

process, but the limitations of carbon steel tools at their best were becoming an obvious constraint on speeds of production. From 1860 to the present day, the emphasis has shifted from development of the basic machine tools and the know-how of production of the required shapes and accuracy, to the problems of machining new metals and alloys and to the reduction of machining costs. With the Bessemer and Open Hearth steel making processes, steel rapidly replaced wrought iron as a major construction material. The tonnage of steel soon vastly exceeded the earlier output of wrought iron and much of this had to be machined. Alloy steels in particular proved more difficult to machine than wrought iron. Towards the end of the 19th century the costs of machining were becoming very great in terms of manpower and capital investment. The incentive to reduce costs by cutting faster and automating the cutting process became more intense, and, up to the present time, continues to be the mainspring of the major developments in the metal cutting field.

The technology of metal cutting has been improved by contributions from all the branches of industry with an interest in machining. Development of cutting tool materials has held a key position. Productivity could not have been increased without the replacement of carbon tool steel by high-speed steel and cemented carbide which allowed cutting speeds to be increased by many times. The special properties required by the cutting edge of tools to machine steel at high speed have led to the development of the most advanced tool materials. This development continues today with employment of ceramic and ultra-hard tool materials. Machine tool manufacturers have developed machines capable of making full use of the new tool materials, while automatic machines, numerically controlled (NC) machines, often with computer control (CNC), and transfer machines greatly increase the output per worker employed. Tool designers and machinists have optimised the shapes of tools to give long tool life at high cutting speed. Lubricant manufacturers have developed many new coolants and lubricants to improve surface finish and permit increased rates of metal removal. The producers of those metallic materials which have to be machined played a double role. Many new alloys were developed to meet the increasingly severe conditions of stress, temperature and corrosive atmosphere imposed by the

requirements of our industrial civilisation. Some of these, like aluminium and magnesium, are easy to machine, but others, like high-alloy steels and nickel-base alloys, become more difficult to cut as their useful properties improve. On the other hand, metal producers have responded to the demands of production engineers for metals which can be cut faster. New heat treatments have been devised, and the introduction of alloys like the free-machining steels and leaded brass has made great savings in production costs. Today metal-cutting is a very large segment indeed of our industry. The motor car industry, electrical engineering, railways, shipbuilding, aircraft manufacture production of domestic equipment and the machine tool industry itself. All of them have large machine shops with many thousands of employees engaged in machining. Metal cutting is a very major industrial activity and the cheapest way to make very many shapes and is likely to continue to be so for many years. The further evolution of the technology of machining to higher standards of efficiency and accuracy and with less intolerable working conditions is of great importance to industry generally. Progress in the technology of machining is achieved by the ingenuity and experiment, the intuition, logical thought and dogged worrying of many thousands of practitioners engaged in the many-faceted art of metal cutting. Notably the worker operating the machine, the tool designer, the lubrication engineer, the metallurgist, are all constantly probing to find answers to new problems created by the necessity to machine novel materials, and by the incentives to reduce costs, by increasing rates of metal removal, and to achieve greater precision or improved surface finish. However competent they may be, there can be few craftsmen, technologists or scientists engaged in this field who do not feel that they would be better able to solve their problems if they had a deeper knowledge of what was happening at the cutting edge of the tool. It is what happens in a very small volume of metal around the cutting edge that determines the performance of tools, the machinability of metals and alloys and the qualities of the machined surface. During cutting, the interface between tool and work material is largely inaccessible to observation, but indirect evidence concerning stresses, temperatures, metal flow and interactions between tool and work material has been contributed by many researches.

1.4 Turning Operation

Turning specific operations include:

1.4.1 Turning

This operation is one of the most basic machining processes. That is, the part is rotated while a single point cutting tool is moved parallel to the axis of rotation.^[1] Turning can be done on the external surface of the part as well as internally (boring). The starting material is generally a workpiece generated by other processes such as casting, forging, extrusion, or drawing. Turning is a process using a single point tool that removes unwanted material to produce a surface of revolution. The machine tool on which this is accomplished is a lathe. This basic operation is the one most commonly employed on metal cutting. The work material is held in the chuck of a lathe and rotated. The tool held rigidly in a tool post and moved at a constant rate along the axis of the bar, c away a layer of metal to form a cylinder or a surface of more complex profile.

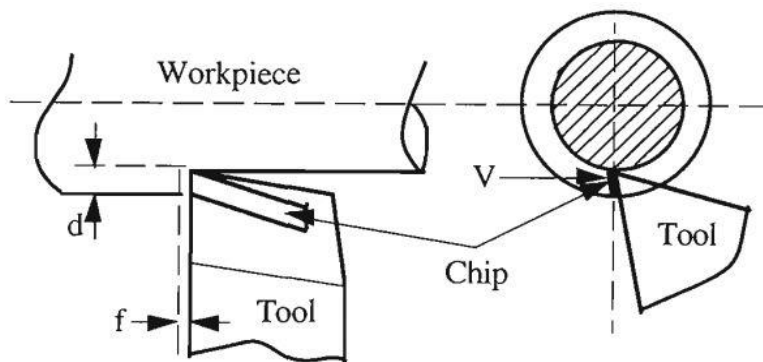

Fig. 1.1 Lathe turning

[ref-5]

The variables adjusted by the operator are the cutting speed V , the feed f , and the depth of cut d . The cutting speed (V) is the rate at which the uncut surface of the work passes the cutting edge of the tool. The feed (f) is the distance moved by the tool in an axial direction at each revolution of the work. The depth of cut (d) is the thickness of metal removed from the bar, measured in a radial direction. The cutting speed and the feed are the two most important parameters which can be adjusted by the operator to achieve optimum cutting conditions. The depth of cut is often fixed by the initial size of the bar and the required size of the product. The geometry of a cutting tool consists of the following elements: rake face,

flank face, cutting edge and nose. The surface of the tool over which the chip flows is known as the rake face. Flank faces are those facing the workpiece. Consequently there are two flank faces, principal and end flank faces. Hence the cutting edges are formed by the intersection of the rake face with the flank faces of the tool. The principal cutting edge performs the major portion of cutting. The nose of the tool is at the intersection of all three faces and may be sharp, but more frequently there is a nose radius between the two flank faces. The tool is so designed and held in such a position that the flank faces do not rub against the freshly cut metal surface. The cutting tool terminology is shown in Fig 1.2. The rake face is inclined at an angle to the axis of the bar of work material and this angle can be adjusted to achieve optimum cutting performance for particular tool materials, work materials and cutting conditions. The rake angle is measured from a line parallel to the axis of rotation of the workpiece (Fig. 1.2b). The tool term is an end flank face, Fig. 1.2a, which also is inclined at such an angle as to avoid rubbing against the freshly cut surface.

This very simplified description of the geometry of one form of turning tool is intended to help the reader without practical experience of cutting to follow the text used later in the thesis. The design of tools involves an immense variety of shapes and the full nomenclature and specifications are very complex. It is difficult to appreciate the action of many types of tool without actually observing or, preferably, using them. The performance of cutting tools is very dependent on their precise shape. In most cases there are critical features or dimensions which must be accurately formed for efficient cutting. These may be, for example, the clearance angles, the nose radius and its blending into the faces, or the sharpness of the cutting edge. The importance of precision in tool making, whether in the tool room of the user, or in the factory of the tool maker, cannot be over estimated. This is an area where excellence in craftsmans

is still of great value.

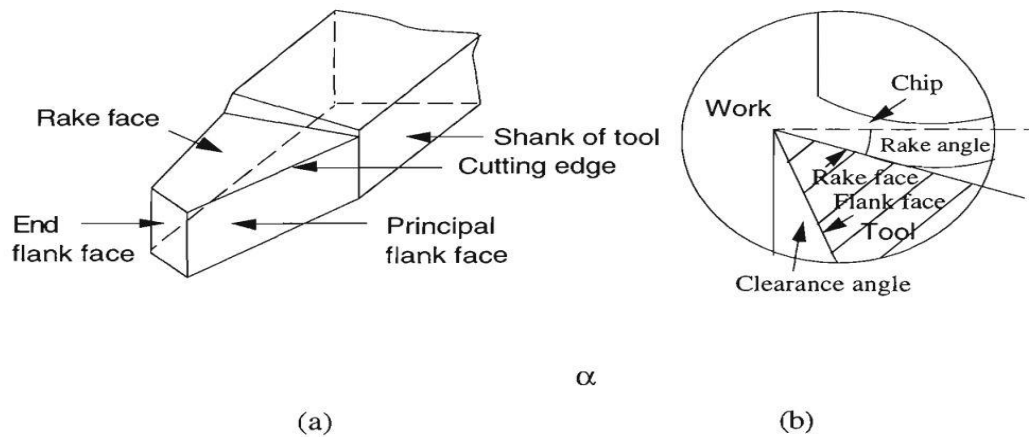

Fig. 1.2 Cutting tool terminology

[ref-3]

1.4.1.1 Tapered turning

a) from the compound slide b) from taper turning attachment c) using a hydraulic copy attachment d) using a C.N.C. lathe e) using a form tool f) by the offsetting of the tailstock - this method more suited for shallow tapers.^[2]

1.4.1.2 Spherical generation

The proper expression for making or turning a shape is to generate as in to generate a form around a fixed axis of revolution. a) using hydraulic copy attachment b) C.N.C. (computerised numerically controlled) lathe c) using a form tool (a rough and ready method) d) using bed jig (need drawing to explain).^[2]

1.4.1.3 Hard turning

Hard turning is a turning done on materials with a Rockwell C hardness greater than 45. It is typically performed after the workpiece is heat treated^[3].

The process is intended to replace or limit traditional grinding operations. Hard turning, when applied for purely stock removal purposes, competes favorably with rough grinding. However, when it is applied for finishing where form and dimension are critical, grinding is superior. Grinding produces higher dimensional accuracy of roundness and cylindricity. In addition, polished surface finishes of $R_z=0.3-0.8\mu m$ cannot be achieved with hard turning alone. Hard turning is appropriate for parts requiring roundness accuracy of 0.5-12 micrometres, and/or

surface roughness of Rz 0.8–7.0 micrometres. It is used for gears, injection pump components, hydraulic components, among other applications.^[3]

1.4.2 Facing

Facing in the context of turning work involves moving the cutting tool at right angles to the axis of rotation of the rotating workpiece.^[1] This can be performed by the operation of the cross-slide, if one is fitted, as distinct from the longitudinal feed (turning). It is frequently the first operation performed in the production of the workpiece, and often the last—hence the phrase "ending up".

1.4.3 Parting

This process, also called **parting off** or **cutoff**, is used to create deep grooves which will remove a completed or part-complete component from its parent stock.

1.4.4 Grooving

Grooving is like parting, except that grooves are cut to a specific depth instead of severing a completed/part-complete component from the stock. Grooving can be performed on internal and external surfaces, as well as on the face of the part (face grooving or trepanning).

Non-specific operations include:

1.4.4.1 Boring

Enlarging or smoothing an existing hole created by drilling, moulding etc.i.e. the machining of internal cylindrical forms (generating) a) by mounting workpiece to the spindle via a chuck or faceplate b) by mounting workpiece onto the cross slide and placing cutting tool into the chuck. This work is suitable for castings that are too awkward to mount in the face plate. On long bed lathes large workpiece can be bolted to a fixture on the bed and a shaft passed between two lugs on the workpiece and these lugs can be bored out to size. A limited application but one that is available to the skilled turner/machinist.^[2]

1.4.4.2 Drilling

It is used to remove material from the inside of a workpiece. This process utilizes standard drill bits held stationary in the tail stock or tool turret of the lathe. The process can be done by separately available drilling machines.

1.4.4.3 Knurling

The cutting of a serrated pattern onto the surface of a part to use as a hand grip using a special purpose knurling tool.^[2]

1.4.4.4 Reaming

The sizing operation that removes a small amount of metal from a hole already drilled.^[2] It is done for making internal holes of very accurate diameters. For example, a 6mm hole is made by drilling with 5.98 mm drill bit and then reamed to accurate dimensions.

1.4.4.5 Threading

Both standard and non-standard screw threads can be turned on a lathe using an appropriate cutting tool. (Usually having a 60, or 55° nose angle) Either externally, or within a bore.^[4] Generally referred to as single-point threading. tapping of threaded nuts and holes a) using hand taps and tailstock centre b) using a tapping device with a slipping clutch to reduce risk of breakage of the tap.^[2]

Threading operations include a) all types of external and internal thread forms using a single point tool also taper threads, double start threads, multi start threads, worms as used in worm wheel reduction boxes, leadscrew with single or multistart threads. b) by the use of threading boxes fitted with 4 form tools, up to 2" diameter threads but it is possible to find larger boxes than this.^[2]

1.4.4.6 Polygonal turning

In which non-circular forms are machined without interrupting the rotation of the raw material.

1.4.5 Process Cycle

The time required to produce a given quantity of parts includes the initial setup time and the cycle time for each part. The setup time is composed of the time to setup the turning machine, plan the tool movements (whether performed manually or by machine), and install the fixture device into the turning machine. The cycle time can be divided into the following four times:

1.4.5.1 LOAD/UNLOAD TIME

The time required to load the workpiece into the turning machine and secure it to the fixture, as well as the time to unload the finished part. The load time can depend on the size, weight, and complexity of the workpiece, as well as the type of fixture.

1.4.5.2 Cut time

The time required for the cutting tool to make all the necessary cuts in the workpiece for each operation. The cut time for any given operation is calculated by dividing the total cut length for that operation by the feed rate, which is the speed of the tool relative to the workpiece.

1.4.5.3 Idle time

Also referred to as non-productive time, this is the time required for any tasks that occur during the process cycle that do not engage the workpiece and therefore remove material. This idle time includes the tool approaching and retracting from the workpiece, tool movements between features, adjusting machine settings, and changing tools.

1.4.5.4 Tool replacement time

The time required to replace a tool that has exceeded its lifetime and therefore become too worn to cut effectively. This time is typically not performed in every cycle, but rather only after the lifetime of the tool has been reached. In determining the cycle time, the tool replacement time is adjusted for the production of a single part by multiplying by the frequency of a tool replacement, which is the cut time divided by the tool lifetime.

Following the turning process cycle, there is no post processing that is required. However, secondary processes may be used to improve the surface finish of the part if it is required. The scrap material, in the form of small material chips cut from the workpiece, is propelled away from the workpiece by the motion of the cutting tool and the spraying of lubricant. Therefore, no process cycle step is required to remove the scrap material, which can be collected and discarded after the production.

1.4.6 Cutting parameters

In turning, the speed and motion of the cutting tool is specified through several parameters.

These parameters are selected for each operation based upon the workpiece material, tool material, tool size, and more.

1.4.6.1 Cutting feed

The distance that the cutting tool or workpiece advances during one revolution of the spindle, measured in inches per revolution (IPR). In some operations the tool feeds into the workpiece and in others the workpiece feeds into the tool. For a multi-point tool, the cutting feed is also equal to the feed per tooth, measured in inches per tooth (IPT), multiplied by the number of teeth on the cutting tool.

1.4.6.2 Cutting speed

The speed of the workpiece surface relative to the edge of the cutting tool during a cut, measured in surface feet per minute (SFM).

1.4.6.2 Spindle speed

The rotational speed of the spindle and the workpiece in revolutions per minute (RPM). The spindle speed is equal to the cutting speed divided by the circumference of the workpiece where the cut is being made. In order to maintain a constant cutting speed, the spindle speed must vary based on the diameter of the cut. If the spindle speed is held constant, then the cutting speed will vary.

1.4.6.3 Feed rate

The speed of the cutting tool's movement relative to the workpiece as the tool makes a cut. The feed rate is measured in inches per minute (IPM) and is the product of the cutting feed (IPR) and the spindle speed (RPM).

1.4.6.4 Axial depth of cut

The depth of the tool along the axis of the workpiece as it makes a cut, as in a facing operation. A large axial depth of cut will require a low feed rate, or else it will result

in a high load on the tool and reduce the tool life. Therefore, a feature is typically machined in several passes as the tool moves to the specified axial depth of cut for each pass.

1.4.7 Tooling

The tooling that is required for turning is typically a sharp single-point cutting tool that is either a single piece of metal or a long rectangular tool shank with a sharp insert attached to the end. These inserts can vary in size and shape, but are typically a square, triangle, or diamond shaped piece. These cutting tools are inserted into the turret or a tool holder and fed into the rotating workpiece to cut away material. These single point cutting tools are available in a variety of shapes that allow for the formation of different features. Some common types of tools are as follows:

- Style A - 0 degree lead-angle turning tools
- Style B - 15 degree lead-angle turning tools
- Style C - 0 degree square nose tools
- Style D - 80 degree included angle pointed-nose tools
- Style E - 60 degree included angle pointed-nose tools
- Cutoff tools
- Form tools

The above tools are often specified as being right or left handed, which indicates in which direction they move along the workpiece while making a cut.

As described in the previous section, live tooling can also be used for turning, which includes the use of mills, drills, reamers, and taps. These are cylindrical multi-point cutting tools that have sharp teeth spaced around the exterior. The spaces between the teeth are called flutes and allow the material chips to move away from the workpiece. The teeth may be straight along the side of the cutter, but are more commonly arranged in a helix. The helix angle reduces the load on the teeth by distributing the forces. Also, the number of teeth on a cutter varies. A larger number of teeth will provide a better surface finish. The cutter teeth cover only a portion of the tool, while

the remaining length is a smooth surface, called the shank. The shank is the section of the cutter that is secured inside the tool holder.

All cutting tools that are used in turning can be found in a variety of materials, which will determine the tool's properties and the workpiece materials for which it is best suited. These properties include the tool's hardness, toughness, and resistance to wear. The most common tool materials that are used include the following:

- High-speed steel (HSS)
- Carbide
- Carbon steel
- Cobalt high speed steel

The material of the tool is chosen based upon a number of factors, including the material of the workpiece, cost, and tool life. Tool life is an important characteristic that is considered when selecting a tool, as it greatly affects the manufacturing costs. A short tool life will not only require additional tools to be purchased, but will also require time to change the tool each time it becomes too worn.

1.5 Chip morphology

The term, chip morphology incorporates the complete geometry of a chip and is influenced to a large extent by the tool geometry and process mechanics. Hence the characterization of chip morphology is defined by analyzing the chip both at the micro and macro level. On the micro level, the chip is characterized as chip shape and at the macro level as chip curl. The chip shape characterizes the chip's cross section in a plane perpendicular to the rake face and the cutting plane. Continuous chips, segmented chips and discontinuous chips could be defined as the most important classification of chip shape and is influenced to a large extent. The chip curl starts at the instance where the chip leaves the rake face. It is characterized by chip flow

direction and is defined by chip flow angle. The chip curl geometry is defined by three important parameters, chip up curl, chip side curl and chip side flow angle, Fig. 1.

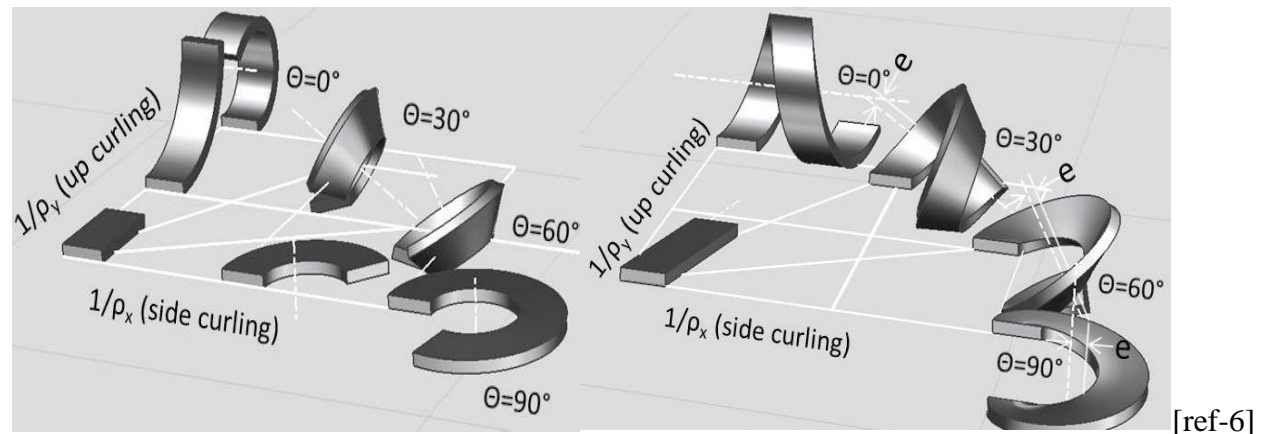

Figure 1 Chip curl variation from up curl to side curl for two different chip flow angles based on Nakayama

In addition, twist angle is used to measure the influence of chip up curl and chip side curl in a 3D chip. Mathematical formulations employing the above defined geometrical parameters were later developed by Nakayama et al to define the chip in 3D practical applications. In addition to chip flow direction, the chip shape also influences the chip curl. Chip flow direction and chip shape are in turn influenced by the chip formation process at the primary deformation zone and friction at the secondary deformation zone.. A more systematical study on chip curl was developed by various research groups over several decades. In addition, chip curl research has been well reviewed and documented through and has resulted in a more quantifiable chip form classification. Among all these fundamental influences, from a cutting tool geometry view point, the cutting tool macro geometry influences chip curl to a large extent. 2D orthogonal cutting would primarily result in an up curled chip with side curling to a very small extent. In 3D oblique cutting, chips are a combination of both side curl and up curl. Chip curl is also influenced to a large extent by the nose configuration and its effect is dependent on the relations between the nose radius and process parameters selected

1.6 Chip Classification:

The first three chip types are the original characterisation, by Dr. Norman Franz. The type of chip that forms depends on many factors, of both tool and material. In general, main factors are

the angle formed by the edge faces of the tool and also the angle at which this is presented to the surface.

Sharpness of the cutting tool does not usually define the type of chip, but rather the quality of the chip, and the clear distinctions between types. A blunt tool produces a degenerate chip that is large, torn and varies from one means of formation to another, often leaving behind a poor quality surface where this means changes.

1.6.1 TYPE I CHIP

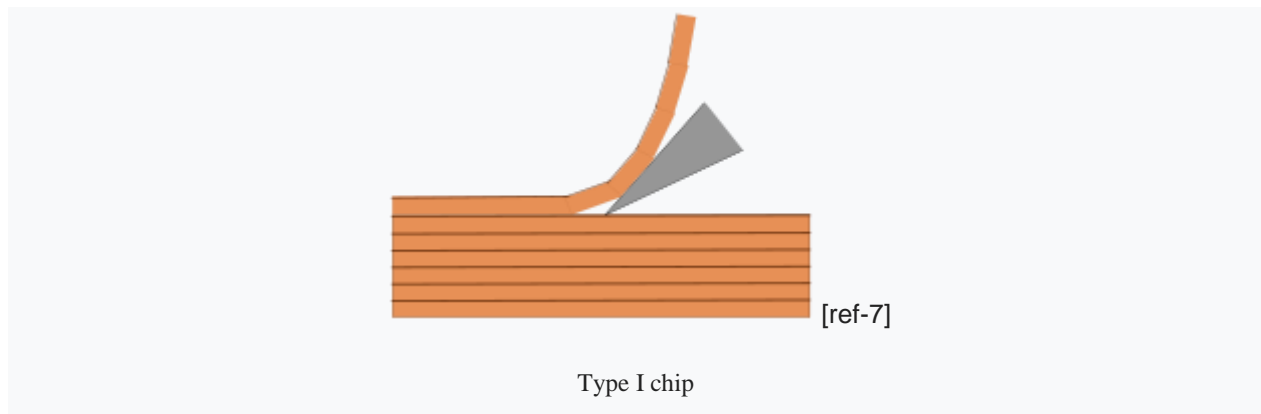

Type I chips form when a material splits *ahead* of the cutting edge, owing to some upwards wedge action of the tool exceeding the tensile strength of the material, perpendicular to the surface. They are thus particularly important in fibrous materials, such as wood, where individual fibres are strong but they may be levered apart relatively easily. Type I chips generally form in cutting by tools with shallow cutting angles.

Type I chips may form long, continuous swarf, limited in size only by the length of cut.

This is the idealised chip formation for wood shavings,^[4] particularly those produced by a well-tuned plane with a finely adjusted mouth.

1.6.2 TYPE II CHIP

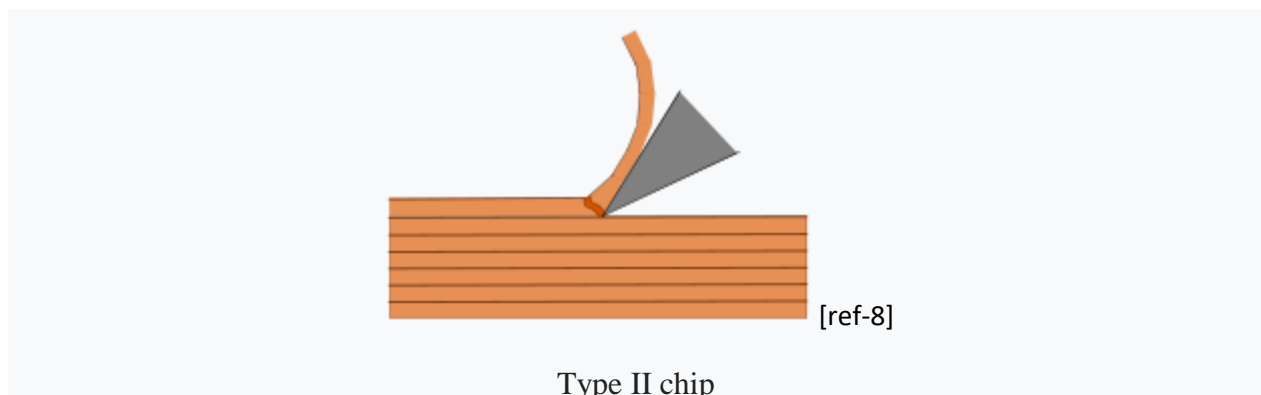

Type II chips form when a shearing force is produced by the wedge of the tool angle. The material fails along a short angled plane, from the apex of the tool edge, diagonally upwards and forwards to the surface. The material deforms along this line, forming an upward curling chip. These chips generally form from intermediate cutting angles. Type II chips may form in ductile materials, such as metals. Type II chips may also form long, continuous swarf.

1.6.3 TYPE III CHIP

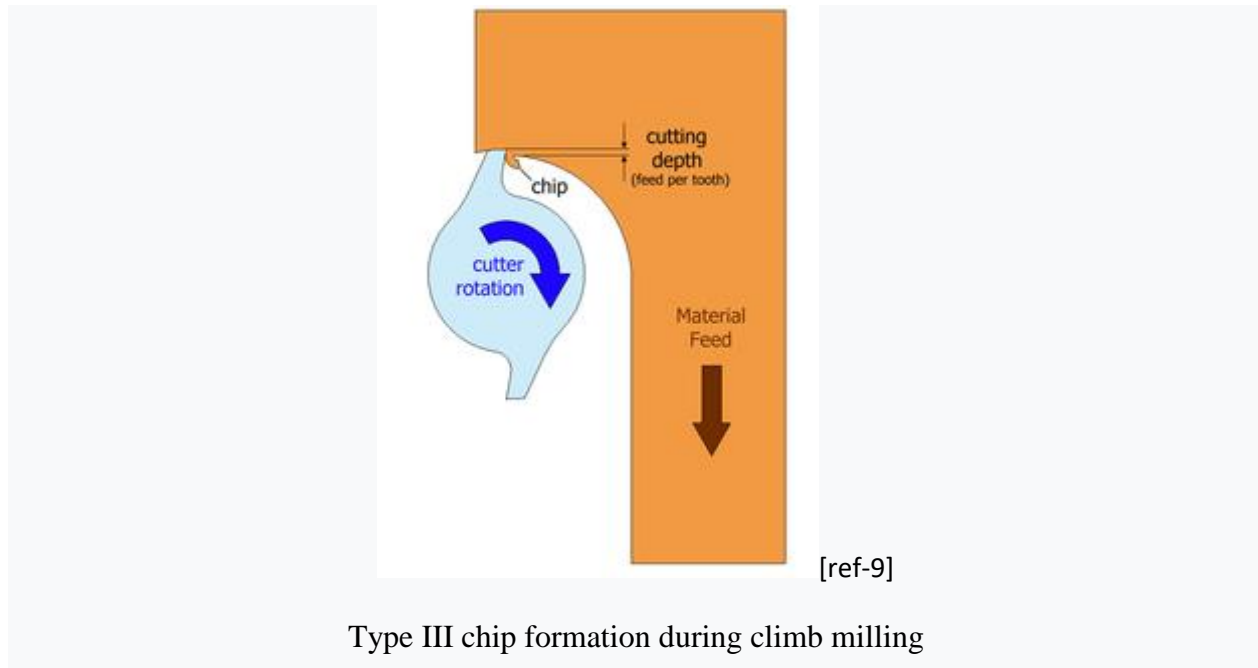

Type III chips form a compression failure of the material, ahead of a relatively obtuse cutting angle, approaching 90° . In some weak or non-ductile materials this may form an acceptable chip, usually as a fine dust, but often it gives rise instead to a random "snowplough" effect where the waste material is bunched up ahead of the tool but not cleared decisively away as a well-formed chip.

This type of chip is formed by routers. It is also formed by woodworking scrapers, although when properly sharpened and used, these form such a thin Type III chip that it instead appears as a well-formed Type II chip. Their waste chip is thin enough that the compression failure volume is small enough to act as for the well-defined shear plane of the Type II.

1.6.4 TYPE 0 CHIP

This type was characterised later, by William McKenzie (1960)

1.7 Mechanisms of Chip Formation:

Depending on the work piece material and the cutting conditions, the following mechanisms of chip formation can be distinguished:

- Continuous chip formation
- Discontinuous chips or Segmented chip formation
- Continuous Chips with built up edge

1.7.1 CONTINUOUS CHIPS:

According to its name, continuous chips have a continuous segment. This chip is form during cutting of ductile material like aluminum, mild steal, cooper etc. with a high cutting speed. The friction between tool and material is minimum during this process. This is form due to continuous plastic deformation of the material by application of tool. These chips have equal thickness throughout the length. It generally gives good surface finish.

However, there are variations in the deformation process that cause more or less significant cleavages or even concentrated shear bands. The lamellae are produced due to thermal or electromechanically processes with a high formation frequency within the kHz range. Lamellar chips occur with highly ductile work piece materials with an increased strength, especially at high cutting speeds (q. v. high speed cutting).

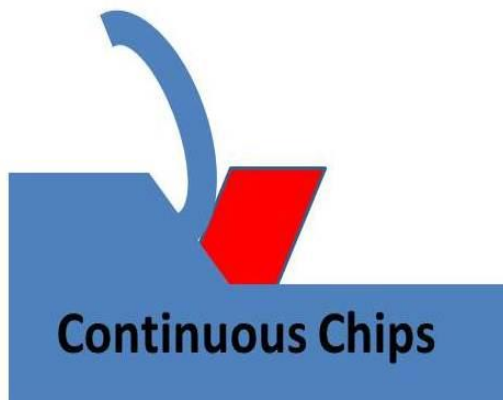

[ref-10]

The most favorable conditions of forming continuous chips are

1. Work piece should have ductile in nature.
2. The rack angle should be large.
3. Friction between work piece and tool should minimum.

4. Cutting speed should high.
5. Deft of cut should be small.
6. Proper use of coolant and lubricant.
7. Tool should have low coefficient of friction.

Continuous chips are the most preferable type of chip due to following benefits.

1. It gives high surface finish of machining ductile material.
2. Continuous chips form when low friction which minimize friction loss.
3. Due to low friction, tool life is high
4. Power consumption is low.

1.7.2 DISCONTINUOUS CHIPS OR SEGMENTAL CHIPS:

According to its name, this chips form in segment. It is form when machining of brittle material like cast iron, brass etc. with slow cutting speed. Chips cut into small segment during cutting. This is formed during slow cutting speed with small rack angle. This chips form in ductile material when the friction between tool and work piece is high. Discontinuous chips in ductile material give poor surface finish and slow machine. It is suitable form of chips of machining brittle material.

The favorable conditions of forming this type of chip are

1. The work piece should have brittle in nature.
2. Slow speed of cutting
3. Small rack angle of tool
4. Depth of cut should large



[ref-11]

1.7.3 CONTINUOUS CHIPS WITH BUILT UP EDGE:

This type of chip is same as the continuous chips except a built edge is form at the face of tool. It is form during machining of ductile metal with excessive friction between tool and work piece. This chip is not smooth as continuous chips. The built up edge form due to high temperature between tool and work piece. This high temperature is due to high friction force between tool and work piece.

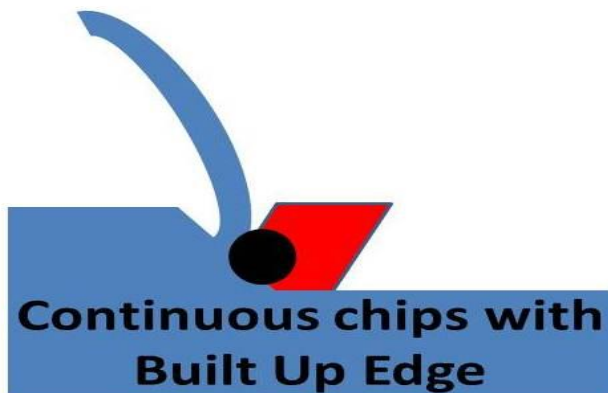

[ref-12]

The common factors promoting built up edge are

1. Cutting of ductile metal.
2. High friction force at the face of tool.
3. High temperature between tool and work piece.
4. Lack of coolant and lubricant.

1.7.4 COMPARISON OF CONTINUOUS CHIPS, DISCONTINUOUS CHIPS AND CONTINUOUS CHIPS WITH BUILT EDGE:

S. No.	Material type	Rack angle	Depth of cut	Cutting speed
Continuous Chips	Ductile	High	Small	Large/medium
Discontinuous Chips	Brittle, Ductile but hard	Medium	High	Low
Continuous chips with built edge	Ductile	Low/Medium	Medium	Medium

[ref-13]

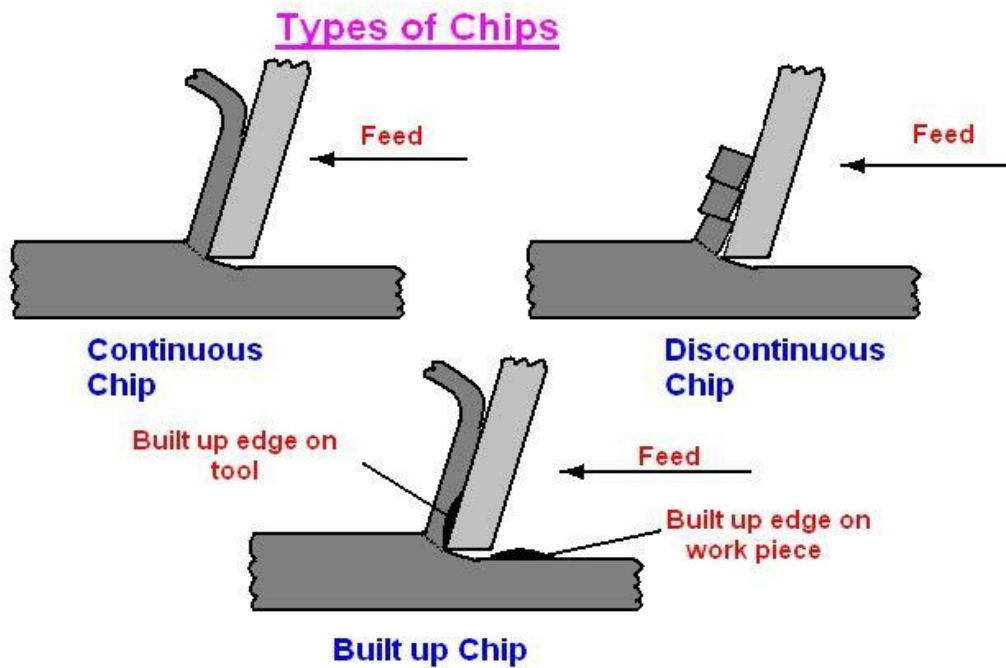

[ref-14]

Fig -Types of chips

1.7.5 CHIP CONTROL:

- The control of chips in high speed production turning, is important to protect both the operator

and the tool.

The long continuous chip that curls round the cutting tool has sharp edges and can inflict deep, painful and

dangerous cuts. It should never be handled with bare hands.

- The usual procedure to avoid the formation of continuous chips is to break the chip intermittently with a chip

breaker, which is clamped on the rake face of the cutting tool.

- The Chip breaker decreases the radius of curvature of the chip.

- A wide variety of cutting tools and inserts with chip breaker features are available. However, with soft work

piece materials, such as mild steel, aluminum chip breaker is generally not as effective.

- With proper lubrication the flow of chips can be controlled and also better tool life can be given.

1.7.6 Mechanism of chip formation in machining ductile materials

During continuous machining the uncut layer of the work material just ahead of the cutting tool (edge) is subjected to almost all-sided compression as indicated in Fig. 1.

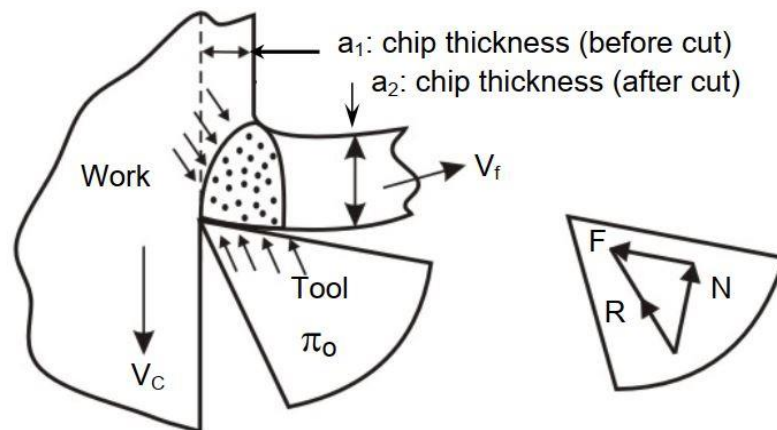

[ref-14]

Fig 1

The force exerted by the tool on the chip arises out of the normal force, N and frictional force, F as indicated in Fig.1. Due to such compression, shear stress develops, within

that compressed region, in different magnitude, in different directions and rapidly increases in magnitude. Whenever and wherever the value of the shear stress reaches or exceeds the shear strength of that work material in the deformation region, yielding or slip takes place resulting shear deformation in that region and the plane of maximum shear stress. But the forces causing the shear stresses in the region of the chip quickly diminishes and finally disappears while that region moves along the tool rake surface towards and then goes beyond the point of chip-tool engagement. As a result the slip or shear stops propagating long before total separation takes place. In the mean time the succeeding portion of the chip starts undergoing compression followed by yielding and shear. This phenomenon repeats rapidly resulting in formation and removal of chips in thin layer by layer. This phenomenon has been explained in a simple way by Piispanen [1] using a card analogy as shown in Fig. 2. In actual machining chips also, such serrations are visible at their upper surface as indicated in Fig..2. The lower surface becomes smooth due to further plastic deformation due to intensive rubbing with the tool at high pressure and temperature. The pattern of shear deformation by lamellar sliding, indicated in the model, can also be seen in actual chips by proper mounting, etching and polishing the side surface of the machining chip and observing under microscope. The pattern and extent of total deformation of the chips due to the primary and the secondary shear deformations of the chips ahead and along the tool face, as indicated in Fig.3, depend upon

[1] Piispanen V., "Theory of formation of metal chips", J. Applied Physics, Vol. 19, No. 10, 1948, pp. 876.

- work material
- tool; material and geometry
- the machining speed (VC) and feed (so)
- cutting fluid application.

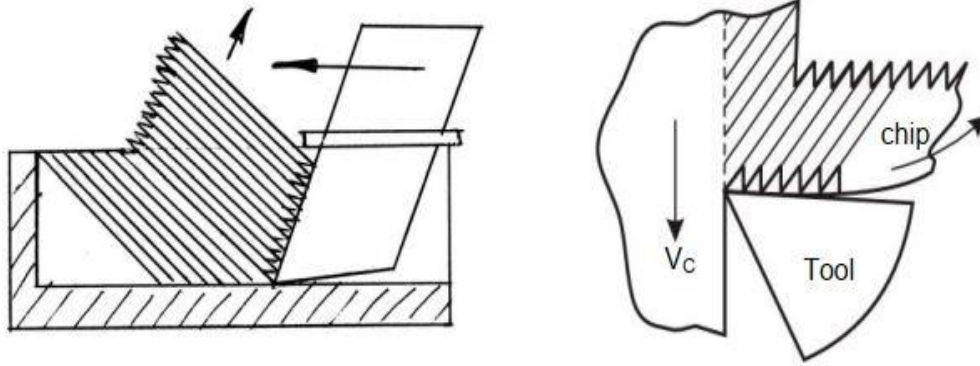

(a) Shifting of the postcards by partial sliding against each other

(b) Chip formation by shear in lamella.

[ref-14]

Fig 2

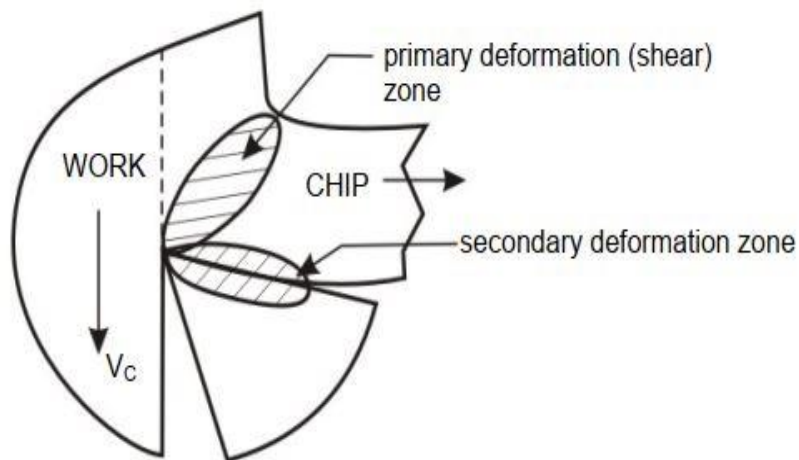

[ref-14]

Fig 3

The overall deformation process causing chip formation is quite complex and hence needs thorough experimental studies for clear understanding the phenomena and its dependence on the affecting parameters. The feasible and popular experimental methods [2] for this purpose are:

- Study of deformation of rectangular or circular grids marked on the side surface as shown in Fig. 4.

- Microscopic study of chips frozen by drop tool or quick stop apparatus
- Study of running chips by high speed camera fitted with low magnification microscope.

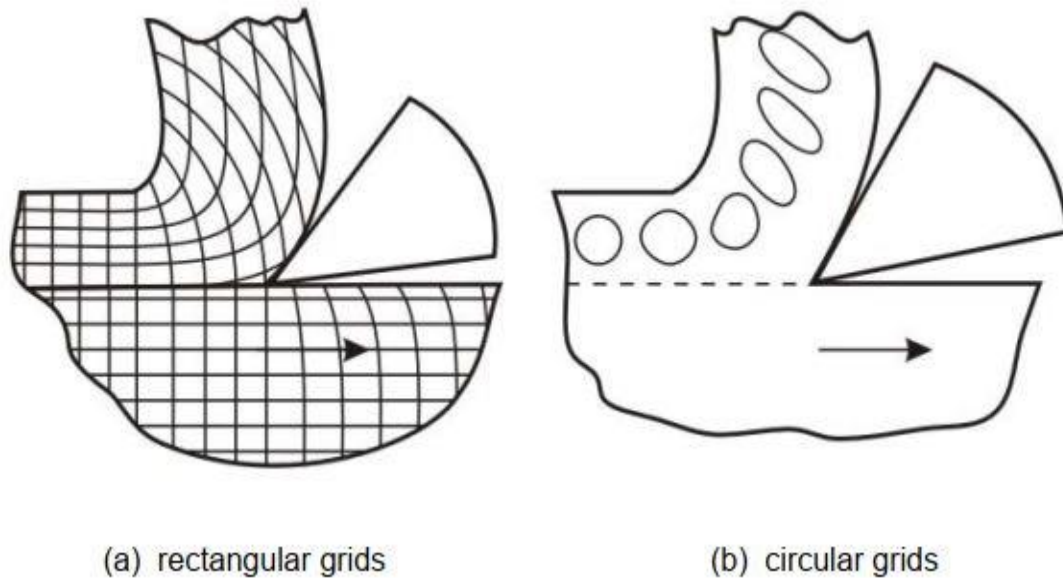

[ref-15]

Fig 4

It has been established by several analytical and experimental methods including circular grid deformation that though the chips are initially compressed ahead of the tool tip, the final deformation is accomplished mostly by shear in machining ductile materials. However, machining of ductile materials generally produces flat, curved or coiled continuous chips.

•1.7.7 Mechanism of chip formation in machining brittle materials

The basic two mechanisms involved in chip formation are

- Yielding – generally for ductile materials
- Brittle fracture – generally for brittle materials

During machining, first a small crack develops at the tool tip as shown in Fig. 5 due to wedging action of the cutting edge. At the sharp crack-tip stress concentration takes place. In case of ductile materials immediately yielding takes place at the crack-tip and reduces the effect of stress

concentration and prevents its propagation as crack. But in case of brittle materials the initiated crack quickly propagates, under stressing action, and total separation takes place from the parent workpiece through the minimum resistance path as indicated in Fig.5. Machining of brittle material produces discontinuous chips and mostly of irregular size and shape. The process of forming such chips is schematically shown in Fig. 6.

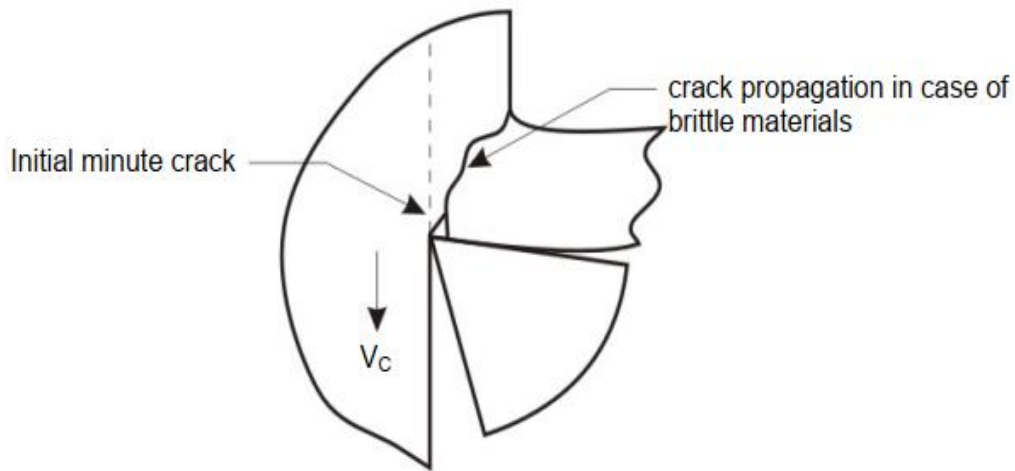

[ref-15]

Fig 5

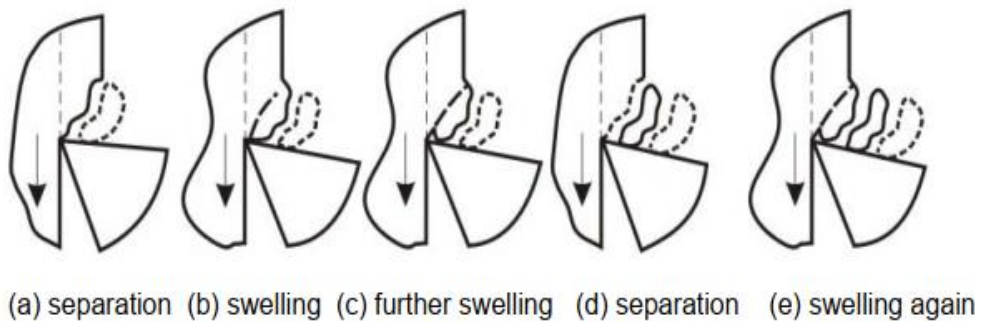

[ref-15]

Fig 6

1.8 Chip reduction coefficient or cutting ratio

The usual geometrical features of formation of continuous chips are schematically shown in

Fig.7.

The chip thickness (a_2) usually becomes larger than the uncut chip thickness (a_1). The reason can be attributed to

- compression of the chip ahead of the tool
- frictional resistance to chip flow
- lamellar sliding according to Piispanen

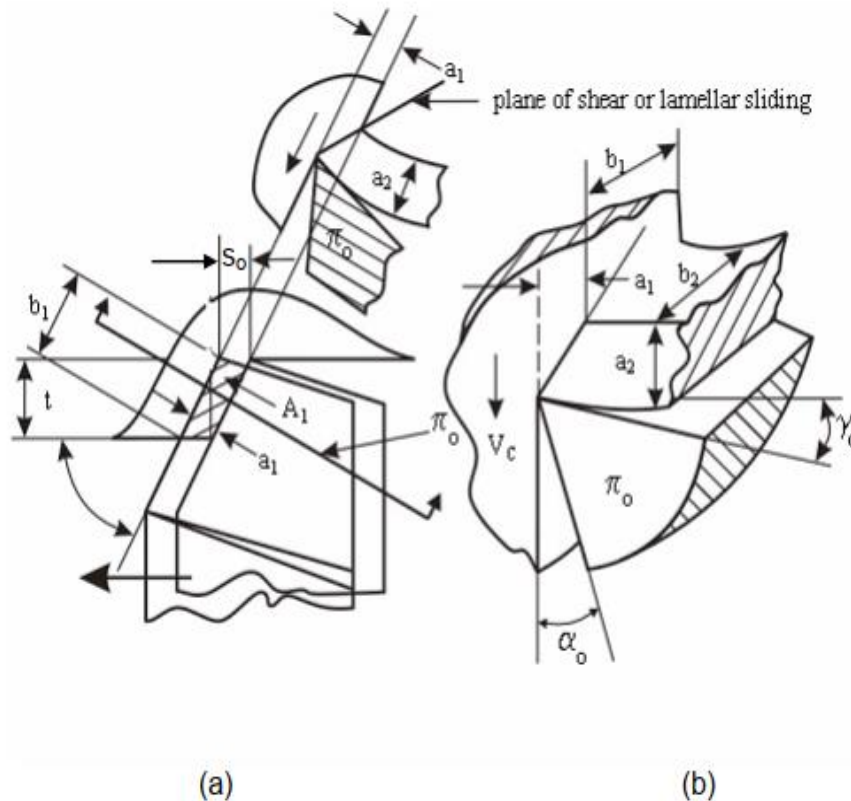

[ref-15]

Fig 7

The significant geometrical parameters involved in chip formation are shown in Fig. 5.7 and those parameters are defined (in respect of straight turning) as:

t = depth of cut (mm) – perpendicular penetration of the cutting tool tip in work surface

s_o = feed (mm/rev) – axial travel of the tool per revolution of the job

b_1 = width (mm) of chip before cut

b2 = width (mm) of chip after cut

a1 = thickness (mm) of uncut layer (or chip before cut)

a2 = chip thickness (mm) – thickness of chip after cut

A1 = cross section (area, mm²) of chip before cut

The degree of thickening of the chip is expressed by

ζ

$\zeta = a_2/a_1$

$\zeta = a_2/a_1 > 1.00$ (since $a_2 > a_1$)

where, ζ = chip reduction coefficient

$$a_1 = s_o \sin \phi \quad (5.2)$$

where ϕ = principal cutting edge angle

Larger value of ζ means more thickening i.e., more effort in terms of forces or energy required to accomplish the machining work. Therefore it is always desirable to reduce a_2 or ζ without sacrificing productivity, i.e. metal removal rate (MRR).

Chip thickening is also often expressed by the reciprocal of ζ as,

$$\frac{1}{\zeta} = r = \frac{a_1}{a_2} \quad (5.3)$$

where, r = cutting ratio

The value of chip reduction coefficient, ζ (and hence cutting ratio) depends mainly upon

- tool rake angle, γ
- chip-tool interaction, mainly friction, μ

Roughly in the following way [3]

$$\zeta = e^{\mu(\frac{\pi}{2} - \gamma_o)} \quad \text{[for orthogonal cutting]} \quad (5.4)$$

$\pi/2$ and γ_o are in radians

The simple but very significant expression (5.4) clearly depicts that the value of ζ can be desirably reduced by

- Using tool having larger positive rake
- Reducing friction by using lubricant

The role of rake angle and friction at the chip-tool interface on chip reduction coefficient are also schematically shown in Fig. 5.8.

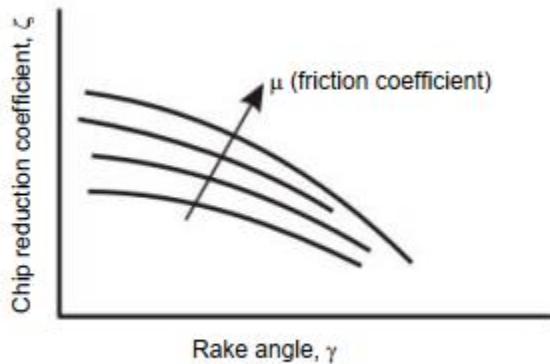

Fig. 5.8 Role of rake angle and friction on chip reduction coefficient

[ref-15]

1.8 The Factors Influencing the Chip Form

There are many factors to influence the chip formation as shown as Fig. 1.7. Apart from the operator's safety, efficiently broken chips may also eliminate the danger of unbroken, hard, hot, long and snarled chips, to the machine tool, cutting tool and the machined surface. Further, the efficiency and effectiveness of a machining operation, among many other influencing factors, are also dependent on the likely chip forms and the breakability of the chip into such forms. Therefore, in planning/designing for machining operations, there arises a need for assessing the breakability for the conditions specified.

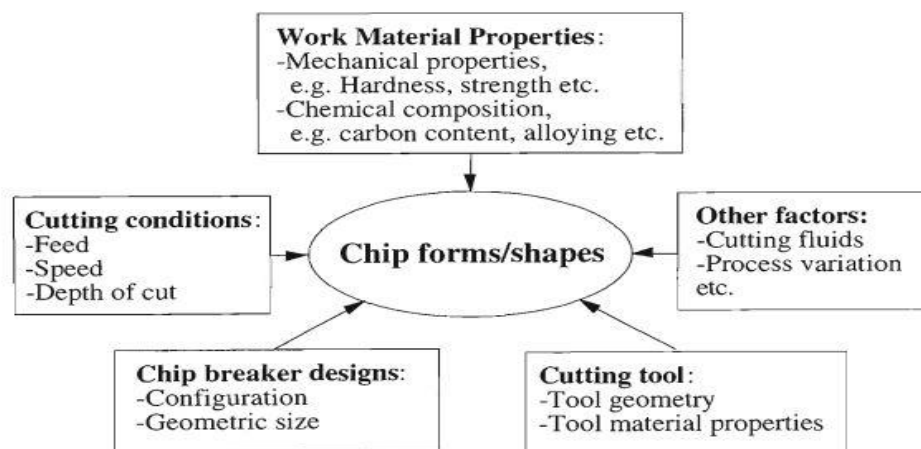
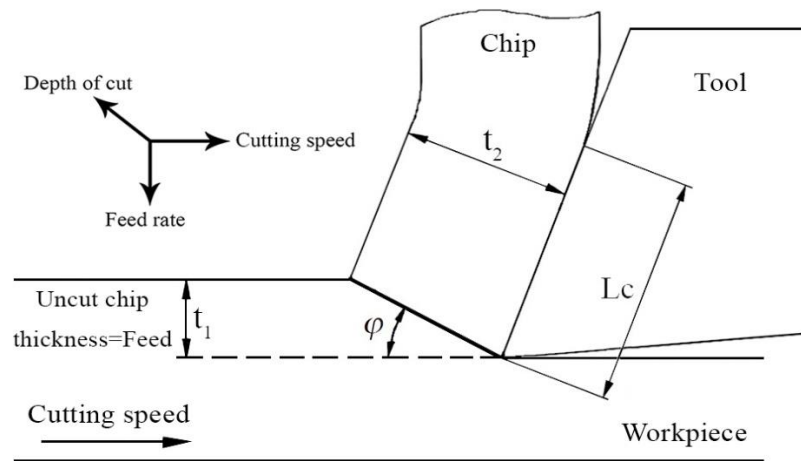

Fig.1.7 The factors influencing the chip forms/shapes

[ref-16]

1.9 Chip Thickness Measurement Technique



[ref-17]

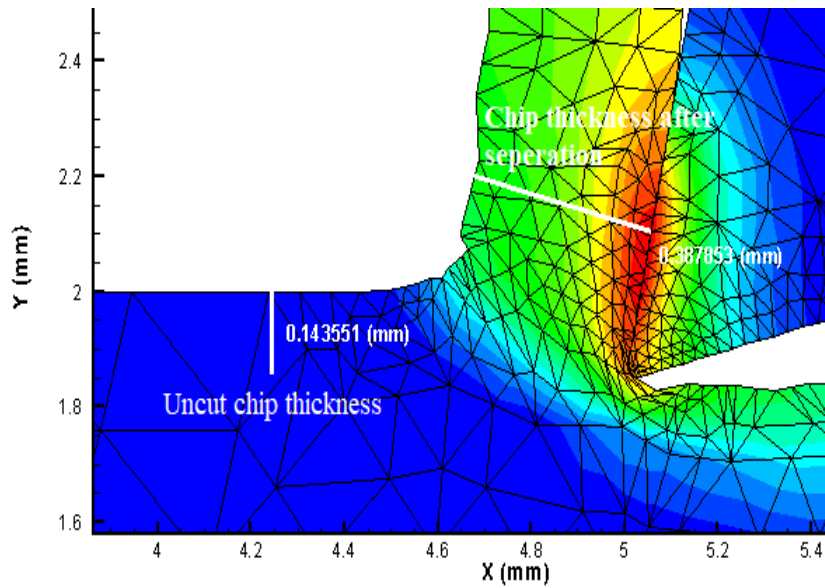

Figure-Chip thickness measurement technique.

2 Literature review

Chapter 2 :LITERATURE REVIEW

2.1 The Review of Major Research on Chip Formation

It has become the elementary knowledge of chip control investigators that there exists a very close relationship between chip flow, chip curling and chip breakage. These components are the basic elements of chip formation. In the past, all the elements were respectively studied in certain machining conditions and their internal relation was investigated in some of the research. The process of chip formation has been investigated by several notable researchers since the beginning of the century. The early work by F.W. Taylor in 1906 in which he introduced an empirical approach to metal cutting, is still regarded as significant in metal cutting research and applications (Taylor, 1907). Since then a number of researchers have developed cutting models and presented theories on chip formation. The chips produced in metal cutting belong to the following model-based classes of chip formation:

- (1) quasi-static 2-D chip formation models for continuous chips;
- (2) dynamic 2-D chip formation models for segmented chips and elemental chips;
- (3) 3-D chip formation models for continuous chips; and

(4) chip formation models for chip breaking. The basic aim of the theoretical research in metal machining is to provide a comprehensive system of ideas and procedures upon which the future technology of metal cutting is expected to operate. Some of the research effort is also of immediate applicability thus providing a rational basis for many rules sanctioned hitherto by experience. It is well known that the central problem of the chip formation mechanism is that it involves a complicated process of plastic deformation. Almost all of the major metal cutting theories known to the world today are based on the orthogonal cutting process producing a continuous chip. While it is fully acknowledged that these theories have in the past laid a strong foundation in our understanding of the process of metal cutting, it is also to be recognised that recent advances in automated machining systems now inevitably require the modelling, predicting, and monitoring of the process of chip breaking for which the traditional theories on chip formation need to be extended in three ways: (1) to include the dynamics of the chip formation process; (2) to develop three-dimensional chip formation models; and (3) to include chip breaking (van Luttervelt, 1977). To accomplish these major objectives it is essential to understand the mechanisms and mechanics of chip flow, chip curling and chip breakage.

Chip formation is part of the process of cutting materials by mechanical means, using tools such as saws, lathes and milling cutters. An understanding of the theory and engineering of this formation is an important part of the development of such machines and their cutting tools.

The formal study of chip formation was encouraged around World War II and shortly afterwards, with increases in the use of faster and more powerful cutting machines, particularly for metal cutting with the new high speed steel cutters. Pioneering work in this field was carried out by Kivima (1952) and Franz (1958).^{[1][2]}

Chip formation is usually described according to a three-way model developed by Franz. This model is best known within the field of machine tool design, although it is also used when an application area, such as woodworking, requires a vocabulary to describe chip formation in more detail than is usually attempted.^{[3][4]}

Many surveys have been done considering different rake angles. Researchers have long investigated its effect on cutting forces, temperature and tool life etc. The works of various authors from various fields have been referred from 2000 onwards. In this paper, previous research and important findings in the orthogonal machining process is critically reviewed. Peng Lo 2000[5] worked on the elastic plastic finite element method so as to investigate the effect of tool rake angle on the chip formed and the machined work piece in precision cutting process. The results indicates that with increase in rake angle cutting force, maximum equivalent strain on the section decreases and top of the chip contour become smoother. McClain et al. 2002 [6] focused on the shear and normal stress distribution in orthogonal metal cutting by the help of FEM (Finite Element Model) Fang and Jawahir 2002 [7] predicted three important machining parameters, i.e. the cutting force ratio, chip thickness, and chip back-flow angle, on the basis of: the universal slip-line mode. Again Fang 2002 [8] discussed and analyzed the forces, chip thickness, and natural tool–chip contact length in machining with a double-rake-angled tool and demonstrated that double-rake-angled tool increases the thrust forces in comparison with single rake angled tool. It is found that tool–chip friction on the tool secondary rake face plays an important role in machining than the tool–chip friction on the tool primary rake face. Tool chip length is one of the important parameter in orthogonal cutting. Toropov and Lim Ko 2003[9] they proposed a new formula for tool chip contact length as a result there is same correspondence between theoretical and experimental results. This research could also be helpful for the analysis of, temperature phenomena, tool strength and wear problems. Fang 2002 [10] proposed a slip-line model in favor of the tool–chip contact on the tool secondary rake face. Chip curl in machining was also taken in to account. Huang and Liang 2003 [11] focused on the finish turning in which the applied feed rate and depth of cut are usually very small. They initially predicted the chip formation forces by transforming the 3-D cutting geometry into an equivalent 2-D cutting geometry. Sutter 2005 [12] in orthogonal turning process at very high speeds investigated the chip geometries formed during cutting by the help of high speed numerical camera with a very short time aperture. Son et al. 2006 [13] showed that because of large rake angle there is unstable cutting process without continuous chip. In this investigation, they applied vibration cutting method for the possibility to reduce the minimum cutting thickness by changing the friction coefficient between tool and work piece. The vibration cutting method is applied to increase the friction coefficient. On the basis of

theoretical investigation and experimental verification results show that the cutting technology is efficient by decreasing the minimum cutting thickness and increasing the friction coefficient. Depending upon materials and vibration conditions the minimum cutting thickness was considerably reduced by 0.02–0.04 mm. Fang and Fang 2007 [14] worked on the theoretical and experimental results in finish machining with a rounded edge tool. The analytical results concludes that with increase in cutting speed and feed rate the tool-chip friction along tool rake face and the round tool edge decreases on the other hand the FE (Finite Element) shows that near the round tool edge high temperature exists there. Yanda et al. 2010 [15] focused on the effectiveness of rake angle. They found that cutting force decreases by increasing rake angle in positive side whereas cutting force increases by increasing rake angle in negative side. Totis and Sortino 2011 [16] worked on the measurement of cutting forces in turning by specifically designed an innovative dynamometer for tri axial cutting on modern CNC lathes. The measured cutting forces were finally compared with theoretical values obtained from mathematical modeling. Kosaraju et al. 2011[17] presented the effects of rake angle and feed rate on cutting forces in orthogonal metal cutting process. On the basis of results they found that with increase in feed rate and rake angle cutting force increases and decreases respectively.

2.1.1 Modelling of chip formation

The following will give a summary of the historical review of major chip formation models available to date that are relevant to chip control studies. It will also provide a description of the basic mechanisms of chip flow, curling, and breakage. F.W.Taylor (1907) realized that the description of the machinability of a material is possible only, if one establishes an empirical relationship between the tool life and cutting process parameters. The result of his research was a deterministic tool life model based on empirically established values of the exponents. Many researchers followed this approach, providing perhaps more detailed insight into the machining process itself, and trying to explain the material removal mechanism. This work eventually resulted in an analytical model of the manufacturing process. Merchant (1944-1945) presented a mathematical model to determine the shear angle by using the minimum energy principle. Outputs of his equations and his experimental

results were not matched well, but this research significantly influenced much of the research that followed in the machining area. A major impact in this field was accomplished by M.E. Merchant (1945) developing the first shear plane model of the cutting process. In this work an initial model of chip flow over plane rake face was developed. This model used the plasticity theory to attempt to obtain a unique relationship between the chip shear plane angle, the tool rake angle, and the friction angle between the chip and tool. This work was instrumental for an intensive research and further developments in process modelling, considering in addition to classical mechanics, the behaviour of material under load and dislocation theory. Shaw et al. (1953), having reviewed all previous shear angle relationships, proposed a modification to the model presented by Lee and Shaffer (1951). An excellent and comprehensive review of the cutting process models was given by M.C. Shaw (1984). Shaffer (1956), in his analysis of orthogonal boring, considered the chip to flow flatly over the tool face to maintain continuity of material a downwards curved shear surface was needed. On the basis of plasticity the position of the shear surface was calculated. This led to a prediction of the chip thickness and cutting force. Okushima and Minato (1959), with the help of their experiments, described the effect of various factors on chip flow. They also derived the equation for the chip angle. They concluded that an increase of nose radius, decrease of depth of cut or a increase of feed makes the chip move away from the workpiece and that cutting speed does not have any effect on the direction of chip flow. By allowing for the variation of the flow stress, for a work hardening material, Palmer and Oxley (1959) presented the shear zone theory. Expanding on the consequences of variable flow stress model, Oxley (1963a) discussed, in detail, the influence of the shear zone mechanism on the frictional angle along the tool-chip interface. Here the chip material adjacent to the interface is under a constant stress and in-plastic state. It is then possible to deduce the interaction between the normal stress in the flow zone and the friction angle. It is shown that the calculated values of the shear angle are not a simple function of the difference between the friction and rake angles. Notably there appears to be a limiting value of friction angle (Oxley, 1963b).

The flow zone chip formation model permits the appraisal of the influence of strain rate in metal cutting and provides a means to investigate the material properties at high strain rates. By devising a somewhat simplified deformation zone concept Oxley (1963c) found that an increase in strain rate is accompanied by an increase in initial shear yield stress. This phenomenon is followed by a decrease in the slope of the plastic stress-strain curve.

Christopherson (1963) discussed a problem somewhat related to Oxley's work. Specifically, the analysis was directed toward the phenomena associated with a curved thin shear zone. One of the virtues of this paper was the careful development of the mathematical arguments and their simplification in view of the basic assumptions. The significance of work material properties and the cyclic nature of the chip formation process in metal cutting was shown by von Turkovich (1967). Also, as an alternative to describing the mechanics of orthogonal cutting through shear angle relationship, a work proposed the use of relationships between the chip compression factor and the contact length factor (De Chiffre, 1990). This contact length approach gives a number of advantages, such as explanation of the operation of tools with restricted contact and of the lubricating action of cutting fluids. Spaans (1970) published fundamental studies of the problem of chip control. He studied the combined effect of a tool corner and cutting edge inclination of chip flow angle. He found that the resultant chip flow angle is found by superposition of the chip flow angle caused by the tool corner and the one caused by the inclination of the straight major cutting edge. The sideward curvature of the chip was neglected in this investigation. Subsequently Spaans and Van Gee(1970) presented a basic analysis of break mechanisms with obstruction chip formers and have laid stress on the effect of preceding chip in chip breaking. Through their high speed filming technique, they have shown that the chip does not break on its root but at the cross section which is subjected to the highest bending moment. Mallock (1981) published chip section micrographs which clearly showed the existence of a secondary shear zone and curled chips presumably formed from a curved primary shear plane. Mallock discussed the role of rake face friction and analyzed forces in terms of a metal's flow stress responding to pressure in the same manner as

soil

deformation.

It was also shown both theoretically and experimentally that a unique relationship in machining is not to be expected (Hill, 1954; and Pugh, 1958). Subsequently, a number of authors charted the manner of non-uniqueness by slip-line field modelling (Kudo, 1965; Dewhurst, 1978; and Childs, 1980). Two qualitative conclusions relevant to chip curl may be drawn. One is that a rake face friction, reducing with distance from the cutting edge, promotes a chip of small radius, and this is in accord with low speed lubricated cutting experiments (Childs, 1972). Second, a straight chip is promoted by a short contact of uniform friction, and this is in accord with chip streaming at high cutting speeds. The slip-line field models demonstrate chip flow is not only non-unique but also very sensitive to small changes in friction. The bounds are so wide as to be of little predictive value. Finite element modelling is now being developed to analyse this more rigorously for plane rake face tools in plane strain (Iwata et al., 1986; Strenkowski, 1990; Moon, 1990; Lin & Lin, 1992; and Wu et al., 1992) for orthogonal chip breaker geometries (Usui, 1990) and, most recently, for non-orthogonal 3-D machining. These

2-6

analyses are computationally successful, but in many cases their predictions do not agree with experiment. One reason could be the lack of knowledge of the high strain rate and temperature flow properties of the chip material. The use of mechanically sound simulation techniques for the design of improved tool geometries remains for the future, and most advances have been made experimentally. In related areas of concern the tool-chip contact length and the associated temperature effects have been extensively studied both theoretically and experimentally (Friedman, 1971; Lenz and Friedman, 1970; Goldblatt, 1988; and Ber and Goldblatt, 1989). Much of the knowledge has come from the process of continuous chip formation and some research findings are from discontinuous (or segmented) chip formation. Not much attention has been paid to the mechanics of the chip breaking process. The "chip producibility" (whether or not broken) has been a major objective in research and applications, not specifically considering the need for breaking the chip into small and manageable size and shapes.

2.1.2 Chip curling mechanisms

2.1.2.1 Chip up-curling

In most shear plane model-based analyses, the chip velocity is considered as constant across the chip thickness and the chip is assumed straight. This is far from a real machining situation, as the chip curls away from the tool face when the tool/chip natural contact length is reached. Significant contributions have been made analytically as well as experimental modelling of chip curl in orthogonal machining (Henriksen, 1953 and Hahn, 1953). Furthermore Kudo (1965) and Dewhurst (1978) have presented slip-line fields to account for this. Shi and Ramalingam (1991) developed a cutting model with a kinematically admissible slip-line field for machining with a cutting tool having a flank wear land. An analysis of chip curvature developed in machining with an obstruction type chip breaker is also given in this work. Subsequently, they extended this work to include an admissible slip-line field for machining with a grooved tool (1992) and compared their simulated results with those previously obtained by Jawahir (1986) experimentally. The curling of chip is the subject of an investigation by Cook and co-workers (1963). In addition to a study of kinematics of chip curl, these authors consider the formation of the built-up edge (BUE) and the influence of additives in the workpiece material. They gave an entirely new explanation of chip curl. Then they proposed that chip curl is a cause rather than the effect and that the BUE and crater may be caused by a predetermined chip curl characteristic. They also presented various experimental facts to support their proposition. They also attempted to explain the mechanism of chip curl and chip straightening with the help of plastic theory, although a complete plasticity solution was not given. They also devised a simple graphical technique to describe the kinematics of curling. They also gave an exponential equation for the radius of curvature of a spiral chip. All these published works considered the machining process under orthogonal conditions only. Nakayama (1962a) in his early work, observed the chip up-curl as a natural phenomenon and considered the effects of chip breakers, built-up edge, and the secondary flow on chip curl. Worthington and Redford (1973) also considered the chip up-curl as resulting from a stable built-up edge.

Okushima et al (1960) described the behaviour of chip in steel cutting in lathe processing with parallel type chip breakers. They derived the chip curl radius of the chip bent by the chip breakers. Using the derived equation for the chip curl radius, propose an expression to represent the conditions in which chips are properly broken. On the basis of this representation, they have drawn a chart for the design of chip breakers.

When machining with grooved tools, owing to the effect of tool restricted contact, the chip flows back into the groove and then, by the obstruction action of the groove-backwall, is curled away from the groove, acquiring a curvature. This effect, which is most commonly utilized in many commercially available chip breakers, has been studied extensively with varying chip groove parameters and tool restricted contact values (Jawahir and Oxley, 1988b). Three chip groove sizes and four chip groove styles were used in the experimental work.

2.1.2.2 Chip side-curling

Certain cutting conditions and tool geometric parameters cause a sideward curvature in the chip. Following early models for chip side-curl (Nakayama, 1972, Bhaktavachalam and Venuvinod, 1973), it has been shown that several major factors influence chip side-curl (van Luttervelt, 1976). These are: (a) the cutting edge is not straight; (b) the primary motion is not rectilinear; (c) the cutting edge is not perpendicular to the primary motion; and (d) the chip compression rate varies along the chip-width.

All these factors cause variations in the chip velocity along the chip width. However, experimental work with certain work materials and cutting conditions has shown that this effect can result from other effects as well. Results of an extensive experimental work, indicating a direct relationship between the chip side-curl radius and the chip side-flow angle, were reported by van Luttervelt (1989). The effect of contact length on chip side-curl has been visualized through a simple experiment by De Chiffre (1990). Nakayama (1992) has exhaustively classified chips according to the degree of

side-curling and up-curling, for both positive and negative values. Based on the cutting mechanism, the following three forms of chip curling, with the geometric analysis of the origin of chip forms, has been shown in two modes-with and without up-curling (Fig.2.1)

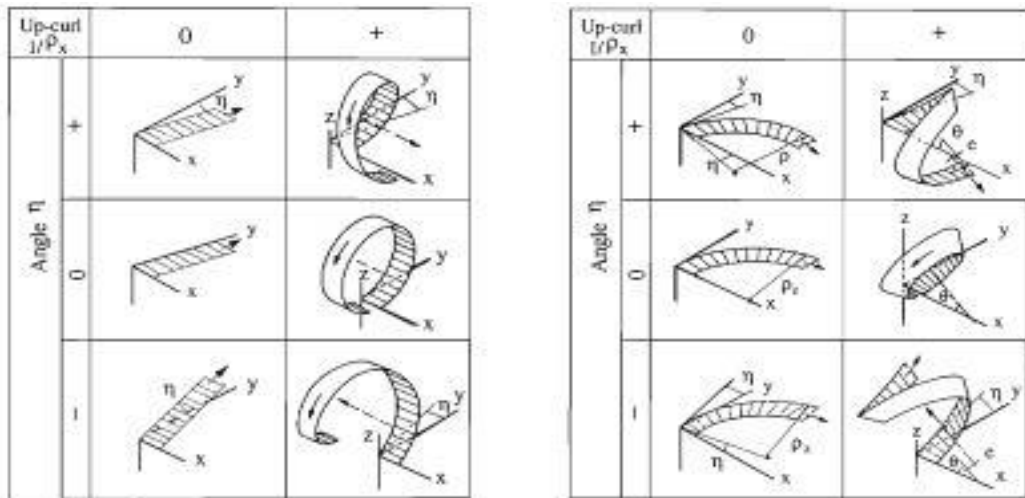

(a) Chip flow with no side-curling

(b) Chip flow with side-curling in the normal direction

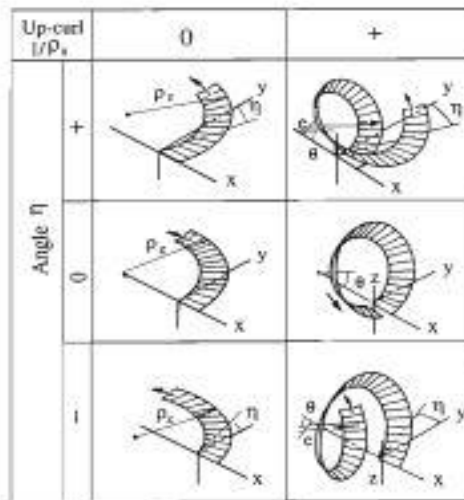

(c) Chip flow with side-curling in the opposite direction

Fig. 2.1 Nakayama's three chip flow modes (1992)

[ref-17]

2.1.3 Chip Breaking Modelling

Henriksen (1954) pioneered the study in chip breaking from the practical point of view. He derived the equation for the radius of chip curvature using an obstruction type chip former. From his fundamental observations, he also proposed a general principle of chip breaker action viz. "Two chip breakers, having the same size of chip flow circle, will break the chip in (practically) the same manner". A significant shortcoming of his analysis was ignoring the effect of tool-chip contact on the rake face.

Nakayama's early work on chip breaking is considered significant in that he presented in it the very first chip breakability criterion (Nakayama, 1962b). This criterion is simply described by

$$\epsilon < \frac{1}{2} \left(\frac{R_0}{R_L} - 1 \right)$$

where, ϵ_b is tensile strain on the chip, t is chip thickness, R_0 is the radius of initial chip curl and R_L is radius of the final chip curl prior to fracture. Having shown three different modes of chip breaking, Nakayama investigated the case involving chip up-curl with a slight side-flow (or side-curl) which results in the free-end of the chip hitting the tool flank surface and thus breaking the chip. In this work, however, Nakayama considered only the most dominant effect of chip up-curl. Several researchers seem to have attempted to develop valid chip breakability criteria, with none fully succeeding because of the complex nature of the problem. Notably chip breakability is a very complicated physical phenomenon which is influenced by numerous factors. Unfortunately, no acceptable theory is available for chip breaking for use at the shop floor level, as almost every theory that has been presented to date seems to be either of academic nature or of a descriptive type with no

specific applications methods recommended. It was also observed that the present knowledge on chip breaking has been incomplete and scattered without much reference to each other. Most notable of these studies are the works by Spaans (1970), Kaldor et al. (1979), Ber et al. (1979), Jawahir (1988c), and Nedess and Hintze (1989). A subsequent study using a high speed filming technique reveals the effects of chip groove configurations on the tool face in orthogonal machining, producing chip up-curl rad (Jawahir, 1990). The early attempt by Henriksen (1953, 1955) to assess chip breakability with an obstruction chip former required enormous experimental work, resulting only in empirical relationships. Subsequently, Kane (1969,1971,1987) provided geometric data for obstruction chip formers through extensive experimental and analytical work by considering the direction of chip flow. A work by Worthington and Rahman (1979) included a modelling of the chip curl mechanisms in machining with grooved chip formers. Many of the previous approaches, however, consider neither the force equilibrium conditions of the chip breaking process nor a valid criterion for chip breaking. A realistic predictive theory must be based on a valid chip breaking model. Therefore, the development of such a model in turn is limited by the lack of fundamental knowledge on the mechanics of chip breaking. X.D. Fang and Jawahir (1989 and 1991a,b) presented a knowledge-based chip breakability rating systems approach for machining with seven steel work materials using eight different chip groove geometries and a flat-faced tool insert. A fuzzy rating system in conjunction with a knowledge database and the corresponding set of knowledge rules is used for predicting the possible levels of chip breakability in of a fuzzy membership value which is allowed to vary between 0 and 1.

2.2 The further review of chip control research

In 1954, L.V. Colwell presented a simple method for predicting the chip flow angle. He proposed that the chip flow direction depends on tool geometry and forces

acting on the chip. Filolenko and Gonchar (1962) measured cutting forces in cylindrical internal and external turning. The ratio of cutting force in internal to external turning increased up to nearly 3 at small diameters (15 mm) and small depth of cut (0.1 mm). Furthermore the chip compression ratio reached values up to 6. The authors explain their findings by a rough analysis of the shear angle. Usui and Hoshi (1963) presented a complete mathematical analysis of the cutting process with controlled contact tools. The method is based upon ideal plastic material theory. The paper is unusually complete since these authors have taken care to include a discussion of nonsteady plastic flow during tool engagement. Oxley (1962) has also analysed the effect of the controlled chip-tool interface obtaining theoretically that the shear angle increases as the contact length decreases. This result is in concordance with the experimental findings. In two papers Trigger and von Turkovich [Trigger and von Turkovich, 1963 and von Turkovich and Trigger, 1963] reported on their investigation of chip formation at high cutting speeds when cutting copper and aluminum of high purity. The analysis involves also a discussion of the physical, i.e., microstructural aspects of high speed shear at very low as well as high initial workpiece temperatures. These two papers contain comprehensive experimental data which are interpreted in conjunction with Merchant's flow zone models. Sata (1963) and von Turkovich (1963) gave reviews of the current standing of metal cutting theory. The shear stresses in the shear plane, tool face friction, and the problem of determination of shear angle are the main concern of the first paper. The second paper is a brief survey of two basic models, i.e., the single shear plane model and the flow zone concept. Albrecht (1963) discussed and criticised the deficiency of the simple shear plane theory, and has shown that flowing effect must be taken into account if an understanding of the deformation process near the tool edge is to be achieved. Considering further the influence of the variable chip thickness he has derived a formula for the "dynamic" shear angle relationship which contains a rate of penetrate factor and the uncut surface slope factor. In 1965 he made a theoretical study of the shape and position of the shear surface in orthogonal cutting on internal and external

cylindrical surfaces. The chip is considered to flow flatly over the tool face. The relations are used to predict cutting forces. Okoshi and Kawata (1967) conducted experimental investigation on the effects of the curvature of work surface on metal cutting and provide experimental data on cutting forces, shear angle, tool chip contact length chip forms, cutting temperature roughness with HSS and cemented carbide tools on various work materials. The tendencies found varied with the combination of material, rake angle and cutting speed. This makes it hard to summarise the results. They conclude that the effects of curvature must be taken into account when a workpiece with a diameter less than 50 mm is machined. Nakayama (1963) found the values of shear stress on shear plane during metal cutting. By performing the test on the chip and not on the uncut metal, he took into consideration the shear strain undergone by the chip during machining, which is in the range of 200% - 500%. Otherwise, it is not possible to attain such high values of strain in test material during bending tests. He also found that the ductility or ultimate surface of chips is larger for Cr-Mo steel and smaller for stainless steel than for carbon steels. Also, the carbon content has no effect on ductility of the chip. Nakayama and Arai (1976), with the help of their experiments on various steels, have expressed the value of shear angle by a simple empirical equation with sufficient accuracy. Using this and analytical equations, three components of cutting forces can be predicted with the error of less than 10%. Since only six data for each work material, which are obtained from a series of cutting tests, are required for this prediction, the storage of cutting force data for flat rake face tool can be simplified remarkably. The values may easily be stored in a data file and are sufficient for prediction of forces. Nakayama and Arai (1977) have studied the roles of brittleness of work material in metal cutting. They have discussed the improvement of machinability due to the brittleness of work material for several steels. The formation of saw-toothed chip, which reduces the cutting force, in case of high speed cutting of hardened steel with a negative rake tool and not in case of normalised steels is major finding of their research. The roughness of the chip surface has been shown to contribute to the chip brittleness considerably. The brittleness of chip of various steels has been measured by a simple bending test. They also find that the chip temperature in conventional cutting of steel is just below the critical temperature, over which the chip becomes very ductile.

Nakayama has been trying to correlate basic theory to the practical problems. Notably in 1978 he carried out a fundamental study on the nature of chip form. He has given a set of basic rules on the form of chip which can be summarised as:

1) Basically the chip has a screw surface. The rake face of cutting tool is tangent to the surface.

2) When the rake face is flat, the radius and pitch of the screw and the inclination and location of the screw axis relative to the cutting edge are determined 2-15

three independent quantities, which are the chip flow angle and the radii of curvature of up-curl and side-curl.

3) When the cutting tool has a helical rake face as in the case of twist drill, the helix angle of the rake face also changes the screw surface. By simple geometrical analysis, he has also given equations for radius of chip helix, pitch and location of chip helix axis.

Nakayama et al (Kluft et al, 1979) conducted a commendable work by reviewing a considerable amount of present knowledge of chip control. They exhaustively collected information on chip classification, fundamental mechanisms of chip formation, alteration of chip material properties, chip flow, upward and sideward curling, effect of tool nose radius, forced chips and the means available for chip control.

The authors conclude that even with an abundance of knowledge of the principles of chip formation, chip breaking and chip control, it is still not possible to predict chip form with sufficient reliability. They also show that the role of work material and cutting fluid is too complicated to be generalised into a set of rules.

Nakayama (1980) presented the first criterion of chip breakability based on his theoretical and experimental work with obstruction chip formers. Accordingly, he identified ultimate tensile strain, chip thickness, inherent radius of curvature of chip, chip cross-section and the limiting radius for the chip to dodge the tool shank as the important parameters in deciding chip breakability. He has also exhaustively discussed the effect of various factors on these parameters like temperature, chip brittleness, feed, chip curl and chip flow space.

Nakayama et al (1981) have investigated the problem of "thin" chip breaking. In

this extensive experimental work they have shown that chips with a curved section can be broken by a small deflection even when they are very thin. This work contributed to 2-16

the design and development of several new and innovative rake face configurations in the manufacture of finish turning inserts. Subsequently Nakayama (1984) identified three parameters for defining the helix forms, namely, outside diameter, pitch and the angle between the chip face and coil axis. He also provided information on the classification of chips, various modes of curling and various radii of curvature given by the "chip disposal", Subcommittee on Machinability in the Japan Society of Precision Engineering (JSPE). Via the use of comprehensive diagrams, he explained four modes of chip breaking. Boothroyd and Trim (1968) were the first to take into account the effect of toolchip contact length and the variation of chip thickness to determine the radius of chip curvature for an obstruction type chip breaker. They also proved their model with the help of experimental results. From their experiments, they also showed that while natural radius of curvature increases with feed, the radius of curvature, when using a chip breaker, decreases with an increase in feed. Also, the chip tool contact length increases with an increase in feed. Furthermore the tool-chip contact length is approximately equal to the chip thickness after deformation. They also concluded that cutting speed has no major influence on the radius of curvature, although an increase in speed increases the value of lower limiting feed. Lambert et al (1968) described the development of a cutting force equation for single point orthogonal cutting which incorporates cutting speed, feed, depth of cut and side rake angle. They firstly derived the basic form of the equation for cutting force and subsequently, with the help of experiments, they found the values of the constants in the equation.

Friedman and Lenz (1970) proposed that contact length and chip curl are predominantly governed by the variation of the temperature field in the tool-chip contact length zone. They base their conclusion on the observation that there is a wide variation of the contact length in machining of steel with tool of different grades, all other variables being constant. Also, their experiments show that there is a good

correlation between contact length and the thermal conductivity of the tool material. van Luttervelt (1976) dealt with the effect of workpiece diameter on chip formation. He introduced the concept of a "kinematical dead" zone between the chip and tool face. The concept proved to be useful in the study of the effect of chip curl steps or grooves on the upward curvature of the chip. He also described the mechanism of chip segmentation, based on a study of movie pictures taken during his experiments. From this experimentation he found that the principal shear zone splits periodically into two zones which move away from each other. Notably between the two shear zones is a growing semi-chip that "slides" over the "kinematically dead" zone of growing dimensions. It was stated that the kinematical model and experimental evidence was found to be in good agreement. Jawahir (1988a) emphasises the need for considering the chip control factor as a machinability criterion along with other conventional criteria such as tool life criterion, material removal rate criterion, force/power criterion, surface finish criterion and machining accuracy criterion. He identified the prediction of chip form and continuous process monitoring, for controlling unforeseen chip form variations, as the two major research directions in the future. In the same work, he also presented a wide literature survey concerning obstruction type and groove type chip breaker, restricted contact length, chip classification and chip breakability. Subsequently Jawahir and Oxley (1988b), through their experiments, showed that a reduced contact length, while increasing the chip stream angle also contributes the reduction in chip curl radius, facilitating better chip breaking. To confirm these findings Jawahir (1988c) conducted a series of experiments on commercially available chip forming tool inserts. This work aimed at assessing the effect of tool restricted contact length on chip streaming and chip breaking. He also investigated the mechanisms of chip up-curling and side curl. He also concluded that chip former tools with rake face lumps cause plastic deformation of the chip leaving wear traces of these lumps on the underside of the chip. He also identified that the effect of such deformation contributes to the chip breaking due to weakening of the chip cross-section. In this work he identified the present trend in chip former tool development as the design and manufacture of a very wide range of specialised chip

formers, each one recommended for specific machining operation. Jawahir and Oxley (1988e) presented the results of a study on chip breaking using tool inserts with grooved chip breakers. From this work they established the effects of tool restricted contact length and the undeformed chip thickness on chip c chip breaking and power consumption rates for a range of different tool geometries. By comparing the power consumption rates for different grooves, they concluded that a raised backwall type is the most uneconomical and the grooves with reduced or no backwall are most economical in terms of power consumed. The most significant conclusion of their work is that efficient chip breaking is achievable at minimum pow consumption.

Johnson (1962) presented a slip-line field theory to explain chip behaviours and a corresponding hodograph for machining with a restricted contact tool. This was further investigated by Usui et al (1962 and 1964) and Oxley (1962) for specific aspe such as the tool face stresses, tool/chip interface friction, cutting forces, chip thi etc.

Worthington and Redford (1973) explained the mechanism of natural chip curl. They also reported the existence of a special built-up edge (BUE) on the tool face whe machining with a restricted contact tool, which causes the chip streaming. They also proposed that the amount of chip curl depends upon the BUE angle, material and cutting conditions. Worthington also found that this special B U E is modified in shape at higher cutting speeds.

Worthington (1975) proposed that the value of undeformed chip thickness, that causes the length of the sticking friction zone to coincide with the land length, is the same as that which causes the chip to straighten. H e also determined the influence of the configuration of primary land.

In another work, Worthington (1976) contacted exhaustive analysis of groove type chip breakers. A s a result he proposed a mechanism for the operation of groove type chip former at high speeds. Furthermore it was suggested that the mechanism is affected by the configuration of special B U E which occurs at high cutting temperatures. H e also suggested that the value of feed, at which groove type chip former begins to operate, can be determined from the discontinuity in cutting force-undeformed chip

thickness relationship. In addition he suggested that chip curl can be predicted if the results for a single test are known, for the same work material. Nakamura (1982) et al conducted an experimental study on the effect of side cutting edge angle, cutting speed, material and chip breaker shape on chip breakage. They also discussed ways to estimate chip breakage for the combination of workpiece material and cutting tools using experimental constants. From their experiments, they found that the side cutting *edge* has no major influence on lower limiting feed while increases in cutting speed and hardness increases the lower limiting feed. Trent (1984) presented an analysis of machinability criteria by considering the chip form/shapes. Zhang (1980) identified three important factors affecting chip curl and breaking, namely chip thickness, radius of chip curvature and the mechanical properties of chip material. Formulae for calculating the width of chip breaker groove were developed according to the elastic and plastic theory. A criterion for chip breaking was also derived, taking into consideration the yield stress, breaking strain of chip material thickness, radius of chip curvature formed in the groove of chip breaker and radius of chip curvature at chip breaking point. De Chiffre (1985) highlighted the limitations of the simple shear zone model in describing the mechanics of chip formation. The main reasons given by him are that the frictional conditions on the rake face, which are not taken into account by the simple shear zone model, play a very important role in determining the process geometry. Also, the application of principle of minimum energy and assumption of a constant friction angle cannot be expected to hold under practical conditions. He discussed some steps that can be made to extend the range validity of the simple shear zone models. He suggested that the stress distribution on the tool rake face and chip curl are inter and should be taken in account. He also presented a mode for chip formation mechanics which incorporates stress distribution on the rake face. Kane (1987) derived the equations for predicting the chip flow direction. From his experiments, he collected data on the chip flow direction and proper width of chip breaker that generated satisfactory chips. He concluded the chip flow direction can be determined prior to the experiment and that a single chip breaker can cover a wide

range of finish cutting conditions. Also, the chip breaker design, that can offer control of chips, is unique to the type of material machined. Nedess (1989) presented analytical and experimental research dealing with the modelling of the chip formation process when using inserts with different three-dimensionally shaped rake face geometries. These models lead to the definition of characteristic parameters with regard to the preliminary assessment of chip control. Characteristic parameters of the modes were the chip flow angle, the effective rake angle and the chip flow radius. Furthermore the up-curling tendency of the chip was expressed by the chip flow radius. Another introduced parameter, chip breaking frequency, proved to be useful in distinguishing quantitatively between broken and unbroken chips. The more relevant literature survey has been integrated into the Introduction of each relevant chapter.

3

Methodology and Experimental investigation

Chapter 3:Methodology and Experimental investigation

The research in this work is based on thickness of chip in different zone during operation of different material like Aluminium,Cast Iron and Stainless Steel.Temperature different of workpiece material in different zone during operation is also investigated.

3.1. Numerical Modeling

The AdvantEdge 3D software uses Finite Element Analysis(FEA) to compute various properties of the tool and workpiece at a certain time. As a machining process involves a lot of mechanical and thermophysical phenomena, the numerical modeling of the process is difficult. So some level of generalization is established in the finite element modeling.

3.2. Experimental setup

The experimental setup is shown in Fig 2

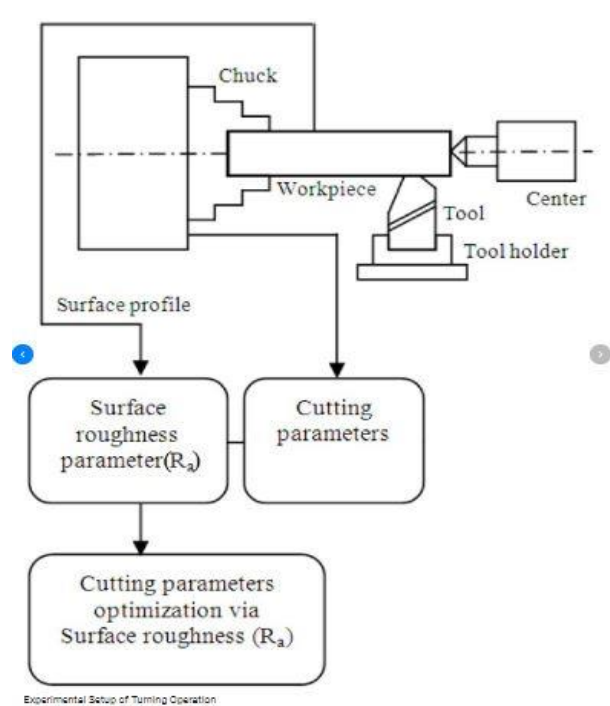

[ref-17]

3.3. EXPERIMENTAL RESULT

Turning operation performed on lathe machine using Aluminium, Cast Iron and Stainless Steel as a work piece and high speed steel as cutting tool. Machining is done at constant depth of cut and varying feed rate and cutting speed. Measuring chip thickness using digital vernier caliper. Results are evaluated after the plotting different graphs.

3.3.1 For Aluminium

Temperature :

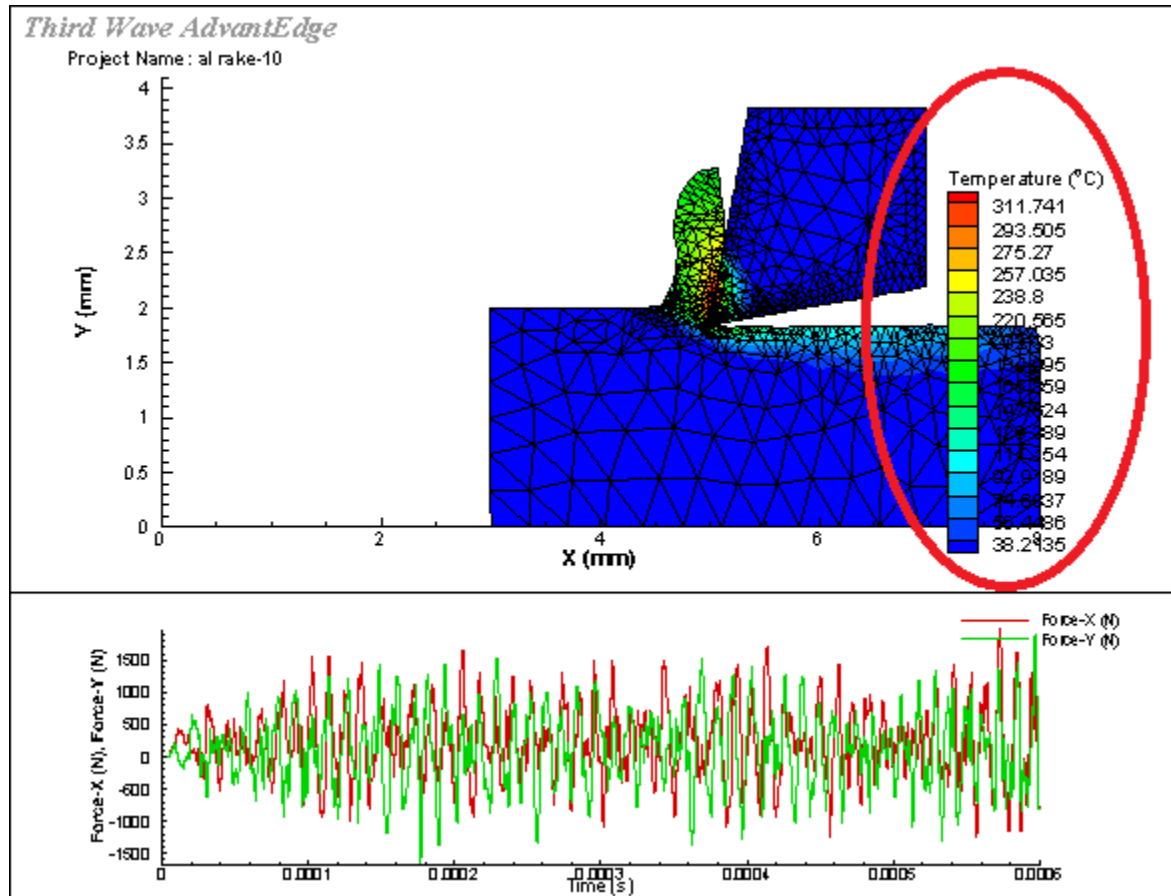

Figure 3.1:Simulation on AdvantEdge.

- **Taken Parameter:**

Material : Aluminium(Al-6061)

Length : 2 m

Depth of cut : 1 m

RPM : 250

Relief Angle : 10 Degrees

Changing Parameter : **Rake Angle**

zone	Rake 10	Rake 12	Rake 14	Rake 16	Rake 18	Rake 20	Rake 22
2	94.614	107.098	88.614	101.855	99.0963	97.4099	99.5326
4	152.23	203.091	135.28	200.83	151.024	180.845	151.174
6	250.23	240.02	201.365	239.603	244.085	214.448	169.408
8	244.019	270.391	203.842	257.325	259.353	230.299	204.22
10	277.346	265.128	252.471	251.166	263.15	247.943	243.784
12	285.65	266.876	276.113	263.844	269.269	263.727	267.308
14	295.611	271.748	286.919	257.906	270.895	261.523	271.01
16	290.637	288.633	275.446	270.133	288.834	262.372	278
18	297.586	297.797	278.022	276.848	290.023	295.792	278.91
20	312.286	285.638	297.543	289.329	284.521	294.347	281.953
22	296.439	286.136	305.323	277.289	270.053	297.679	289.25
24	302.232	297.643	306.912	274.859	275.353	282.93	285.299
26	299.188	292.226	311.694	278.065	280.699	301.192	280.023
28	301.328	301.226	301.974	291.539	292.283	289.163	289.546
30	302.167	314.029	312.258	312.727	291.542	280.637	299.608

Table 3.1-Variation of chip temperature with varying rake angle for Aluminium(Al-6061) at different zone.

Chip Temperature:

Rake Angle	Avg. Temp (degree celsius)
10	261.38
12	262.88
13	265.8453
14	266.9835
15	255.5851
16	256.2212
18	255.3454
20	253.3538
22	245.935

Table- Variation of average chip temperature with varying rake angle for Aluminium(Al-6061).

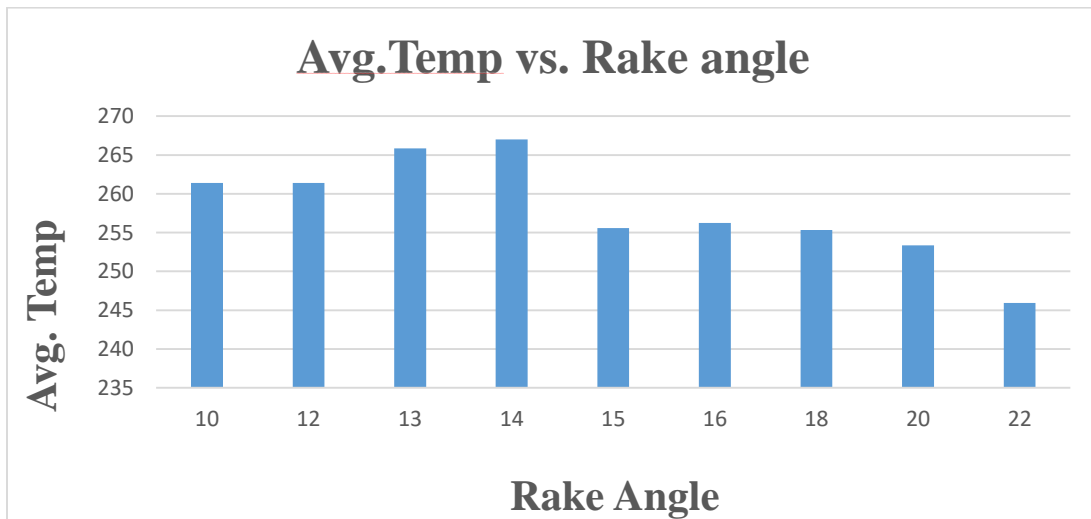

Table-Variation of average chip temperature with varying rake angle for Aluminium (Al-6061)

- **Taken Parameter:**

Material : Aluminium(Al-6061),

Length : 2 m

Depth of cut : 1 m

RPM : 250

Rake Angle : 12 Deg

Changing Parameter : Relief Angle

Relief angle	Avg. temp
8	260.957
10	252.2892
12	264.2978
14	261.9224

Table-Variation of average chip temperature with varying relief angle for Aluminium(Al-6061).

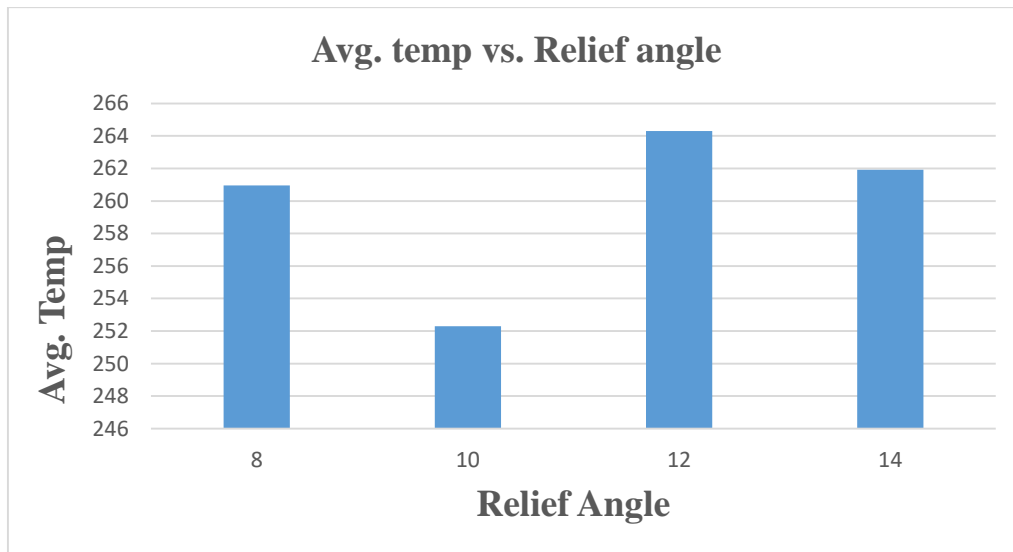

Variation of average chip temperature with varying relief angle Aluminium(Al-6061)

- **Taken Parameter:**
 Material : Cast Iron(J431 G1800)
 Length : 2 m
 Depth of cut : 1 m
 RPM : 250
 Relief Angle : 8
Changing Parameter : Rake Angle

Aluminium(Al-6061)

Relief angle	Avg. temp
8	260.957
10	252.2892
12	264.2978
14	261.9224

Table -Variation of average chip temperature with varying relief angle for **Aluminium(Al-6061)**

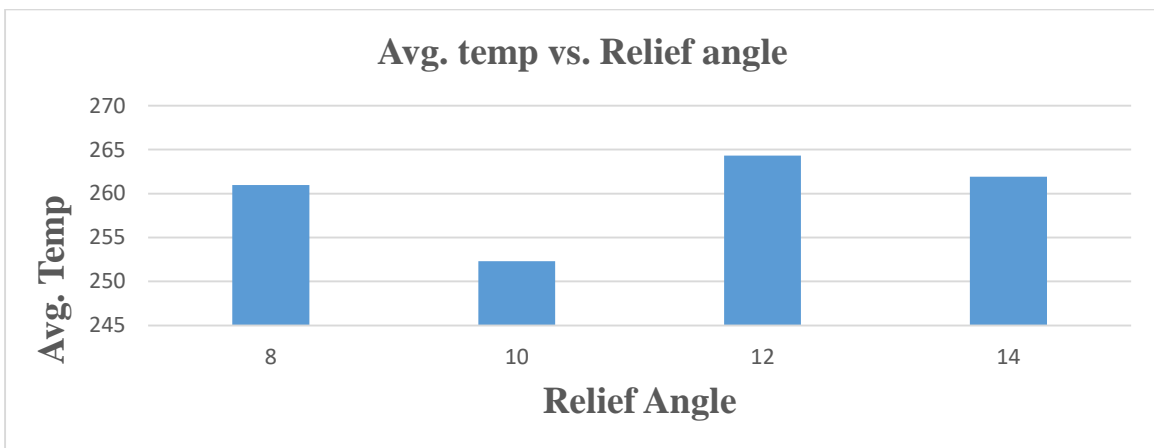

Variation of average chip temperature with varying relief angle Aluminium(Al-6061)

- **Taken Parameter:**

Material : Cast Iron(J431 G1800)
Length : 2 m
Depth of cut : 1 m
RPM : 250
Relief Angle : 8
Changing Parameter : Rake Angle

Cast Iron(J431 G1800)

Rake angle	Avg. temp
0	382.2507
1	370.9271
2	363.339
3	364.7622
4	358.3618

Table- Variation of average temperature with varying rake angle for Cast Iron(J431 G1800)

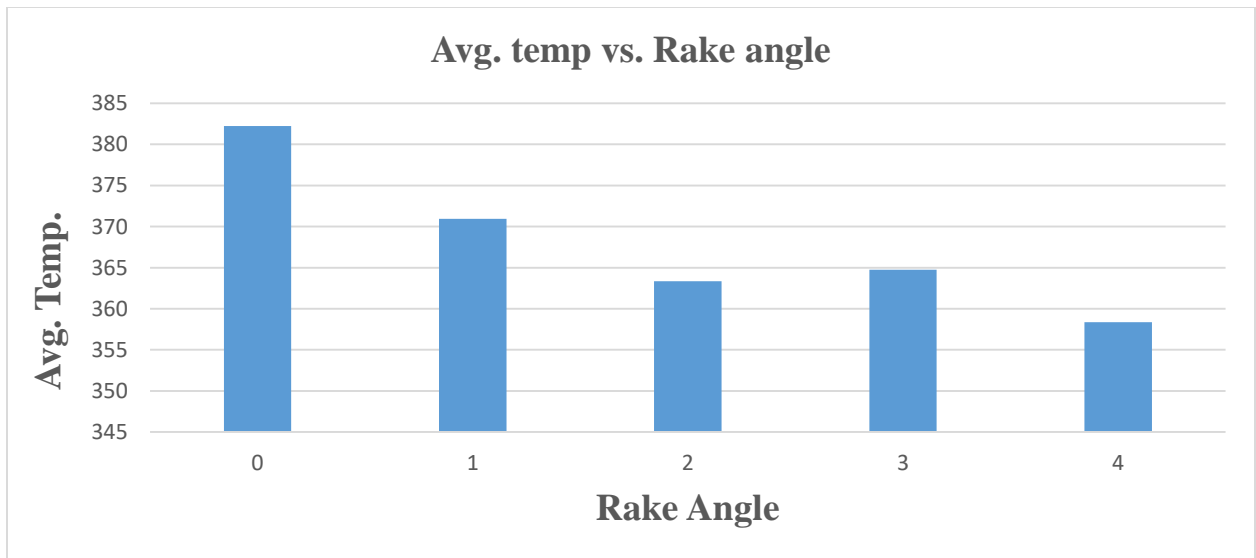

Figure- Variation of average temperature with varying rake angle for Cast Iron(J431 G1800)

Stainless Steel(304L)

- **Taken Parameter:**
Material : Stainless Steel(304L).
Length : 2 m
Depth of cut : 1 m
RPM : 250
Relief Angle : 8
Changing Parameter : Rake Angle

Rake angle	Avg. temp
8	501.5819
9	505.6829
10	510.5254

Table-Variation of average temperature for varying rake angle for Stainless Steel(304L).

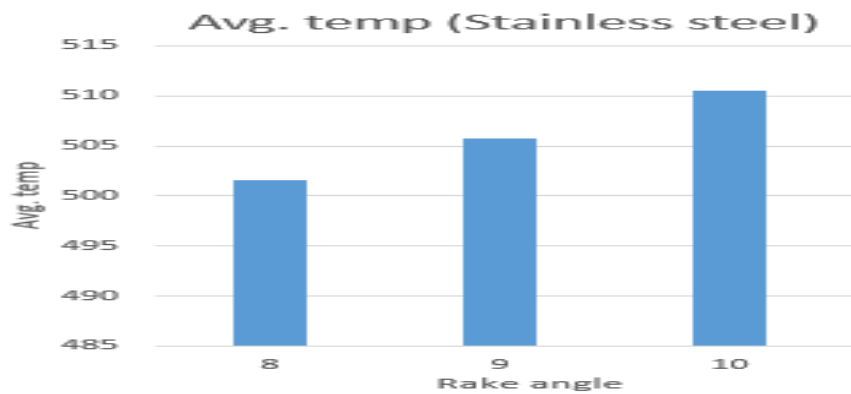

Figure-Variation of average temperature for varying rake angle for Stainless Steel(304L)

Chip Thickness

- **Taken Parameter:**
Material : Aluminium(Al-6061),
Length : 2 m
Depth of cut : 1 m
RPM : 250
Relief Angle : 8
Changing Parameter : Rake Angle

Rake angle	zone 10	zone 20	zone 30	uncut
12	0.365532	0.449151	0.395865	0.143227
13	0.3888	0.40924	0.39558	0.136362
14	0.36844	0.4096	0.37648	0.14038
15	0.361974	0.471503	0.353865	0.14733
16	0.349888	0.399915	0.342244	0.151991
17	0.386024	0.415614	0.376072	0.145627
18	0.360382	0.344234	0.382333	0.153663
19	0.358165	0.359967	0.374783	0.138365
20	0.334325	0.376219	0.334026	0.136364
21	0.304252	0.36286	0.383744	0.137465
22	0.318077	0.360574	0.354023	0.141697

Table-Variation of chip thickness with varying rake angle for Aluminium(Al-6061)

Aluminium(Al-6061)

Average thickness:

Rake angle	Avg.thickness
12	0.403516
13	0.397873
14	0.38484
15	0.395781
16	0.364016
17	0.39257
18	0.362316
19	0.364305
20	0.34819
21	0.350285
22	0.344225

Table-Variation of average thickness for varying rake angle for Aluminium(Al-6061)

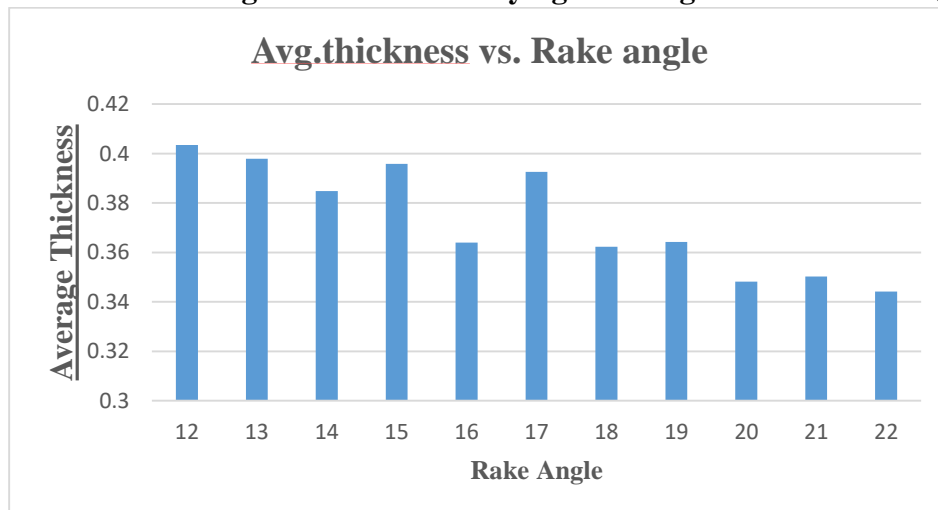

Figure-Variation of average chip thickness for varying rake angle for Aluminium(Al-6061)

Relief angle	Avg.thickness
8	0.420074
9	0.400396
10	0.403486
11	0.413602
12	0.394213
13	0.377862
14	0.408229

Table-Variation of average temperature for varying relief angle for Aluminium(Al-6061)

- **Taken Parameter:**
Material : Aluminium(Al-6061),
Length : 2 m
Depth of cut : 1 m
RPM : 250
Rake Angle : 12 Deg
Changing Parameter : Relief Angle

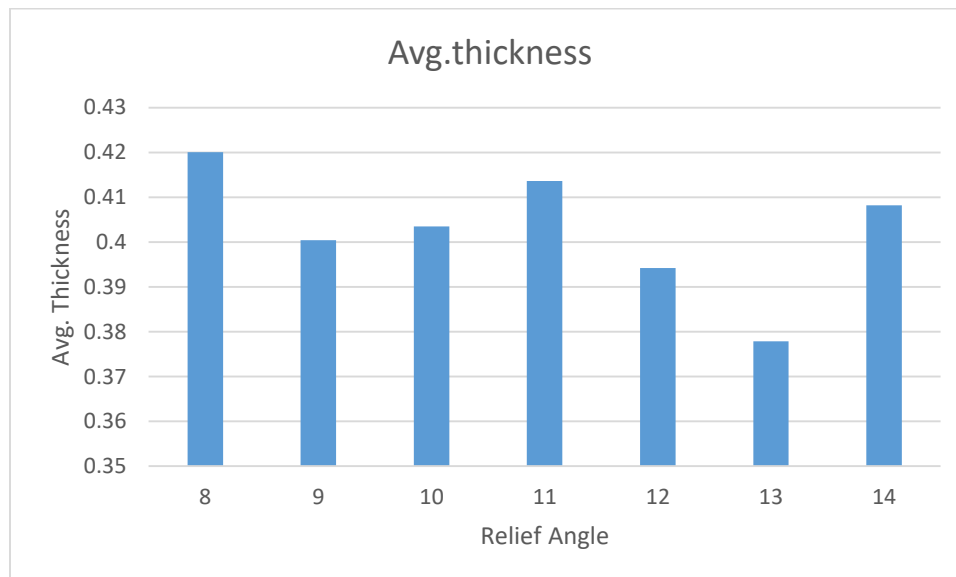

Figure-Variation of average thickness for varying relief angle for Aluminium(Al-6061)

Cast Iron(J431 G1800)

- Taken Parameter:
Material : Cast Iron(J431 G1800)
Length : 2 m
Depth of cut : 1 m
RPM : 250
Relief Angle : 8
Changing Parameter : Rake Angle

<u>Rake angle</u>	<u>Avg.thickness</u>
<u>0</u>	<u>0.332983</u>
<u>1</u>	<u>0.302763</u>
<u>2</u>	<u>0.253685</u>
<u>3</u>	<u>0.244566</u>
<u>4</u>	<u>0.331384</u>
<u>5</u>	<u>0.31369</u>

Table-Variation of average thickness for varying rake angle for Cast Iron(J431 G1800)

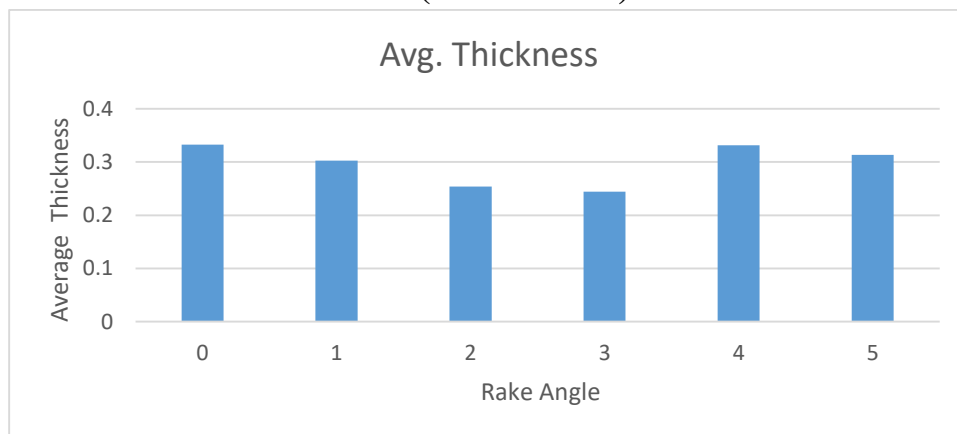

Figure-Variation of average thickness for varying rake angle for Cast Iron(J431 G1800) .

Stainless Steel(304L)

- **Taken Parameter:**
Material : Stainless Steel(304L)
Length : 2 m
Depth of cut : 1 m
RPM : 250
Relief Angle : 8
Changing Parameter : Rake Angle

Rake angle	Avg. thickness
7	0.316815
8	0.296001
9	0.272298

Table-Variation of average thickness for varying rake angle for Stainless Steel(304L).

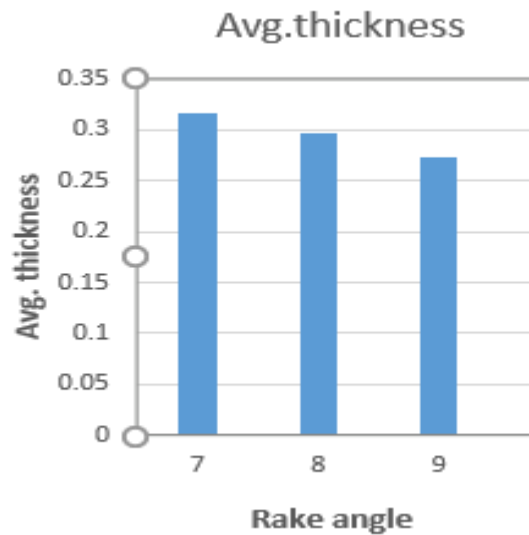
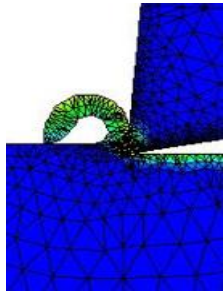
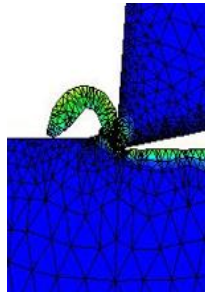

Figure-Variation of average thickness for varying rake angle for Stainless Steel(304L)

3.3.2 For Stainless Steel



Rake 1



Rake 2

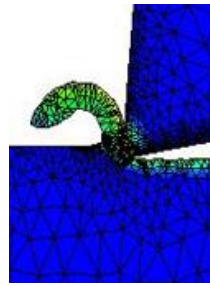

Rake 2

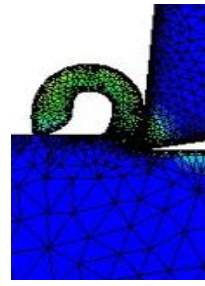

Rake 5

3.3.3 For Cast Iron

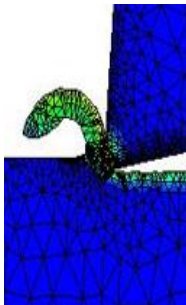

Rake 7

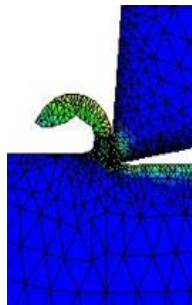

Rake 8

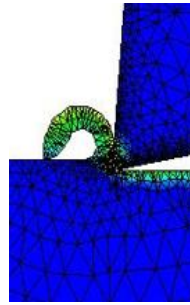

Rake 9

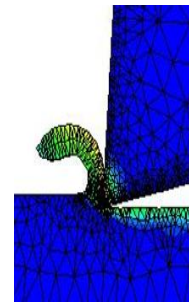

Rake 10

3.4 Result Analysis

Temperature

- Aluminium(Al-6061)-

1. For Rake angle **14** degree the average chip temperature is **highest** and for **22** degree it is **lowest**.
2. For Relief angle **12** degree the average chip temperature is **highest** and for **10** degree it is **lowest**.

- Cast Iron(J431 G1800)

For Rake angle **0** degree the average chip temperature is **highest** and for **4** degree it is **lowest**.

- Stainless Steel(304L)

For Rake angle **10** degree the average chip temperature is **highest** and for **8** degree it is **lowest**.

Chip Thickness

- Aluminium(Al-6061)-

1. For Rake angle **12** degree the average chip thickness is **highest** and for **22** degree it is **lowest**.
2. For Relief angle **8** degree the average chip temperature is **highest** and for **13** degree it is **lowest**.

- Cast Iron(J431 G1800)

For Rake angle **0** degree the average chip thickness is **highest** and for **3** degree it is **lowest**.

- **Stainless Steel(304L)**

For Rake angle 7 degree the average chip temperature is **highest** and for 9 degree it is **lowest**.

4

REFERENCES

Chapter 4: REFERENCES

- [1] Atkins, Anthony G. (2008). *The Science and Engineering of Cutting*. Butterworth. p. 102. ISBN 0-7506-8531-X.
- [2] Lee, Leonard (1995). "Appendix 1: Chip Classification". *Complete Guide to Sharpening*. Taunton Press. pp. 229–234. ISBN 1-56158-125-9.
- [3] Hoadley, R. Bruce (2000). *Understanding Wood: A Craftsman's Guide to Wood Technology* (2nd. ed.). Taunton Press. pp. 162–163. ISBN 1-56158-358-8
- [4] Steve Elliott. "Shaving Formation
- [5] Ship-Peng Lo, —An analysis of cutting under different rake angles using the finite element method|| *Journal of Materials Processing Technology*, 105; 43-151, 2000.
- [6] Ben McClain, Stephen A. Batzer, G. Ivan Maldonado, —A numeric investigation of the rake face stress distribution in orthogonal machining|| *Journal of Materials Processing Technology* 123,pp. 114-119, 2002.
- [7] N. Fang a, I.S. Jawahir, —Analytical predictions and experimental validation of cutting force ratio, chip thickness, and chip back-flow angle in restricted contact machining using the universal slip-line model|| *International Journal of Machine Tools & Manufacture* 42,pp. 681–694, 2002.
- [8] N. Fang, —Machining with tool–chip contact on the tool secondary rake face—Part II: analysis and discussion|| *International Journal of Mechanical Sciences* 44, pp. 2355–2368, 2002.
- [9] Andrey Toropov, Sung-Lim Ko, —Prediction of tool-chip contact length using a new slip-line solution for orthogonal cutting|| *International Journal of Machine Tools & Manufacture* 43,pp. 1209–1215, 2003.
- [10] N. Fang, —Machining with tool–chip contact on the tool secondary rake face—Part I: a new slip-line model|| *International*

Journal of Mechanical Sciences 44,pp. 2337–2354, 2002.

[11] Yong Huang, Steven Y. Liang, —Force modeling in shallow cuts with large negative rake angle and large nose radius

tools—application to hard turning|| Int J Adv Manuf Techno 22 ,pp. 626–632, 2003.

[12] G. Sutter, —Chip geometries during high-speed machining for orthogonal cutting conditions|| International Journal of Machine Tools & Manufacture 45, pp. 719–726, 2005.

[13] SeongMin Son, HanSeok Lima, Jung Hwan Ahn, —The effect of vibration cutting on minimum cutting thickness||

International Journal of Machine Tools & Manufacture 46, pp. 2066–2072, 2006.

[14] N. Fang, G. Fang, —Theoretical and experimental investigations of finish machining with a rounded edge tool|| Journal of

Materials Processing Technology 191, pp. 331–334, 2007.

[15] Hendri Yanda, Jaharah A. Ghani & Che Hassan Che Haron, —Effect of Rake Angle on Stress, Strain and Temperature on

the Edge of Carbide Cutting Tool in Orthogonal Cutting Using FEM Simulation|| ITB J. Eng. Sci., Vol. 42,pp.179-194, 2010.

[16] G. Totis n, M. Sortino, —Development of a modular dynamometer for triaxial cutting force measurement in turning||

International Journal of Machine Tools & Manufacture 51,pp. 34–42, 2011.

[17] Satyanarayana Kosaraju, Venu Gopal. Anne and Venkateswara Rao.Ghanta, —Effect of Rake Angle and Feed Rate on

Cutting Forces in an Orthogonal Turning Process|| International Conference on Trends in Mechanical and Industrial

Engineering (ICTMIE'2011) Bangkok Dec., 2011.

5 Appendix

- **Aluminium(Al-6061)-**
Rake angle-12⁰

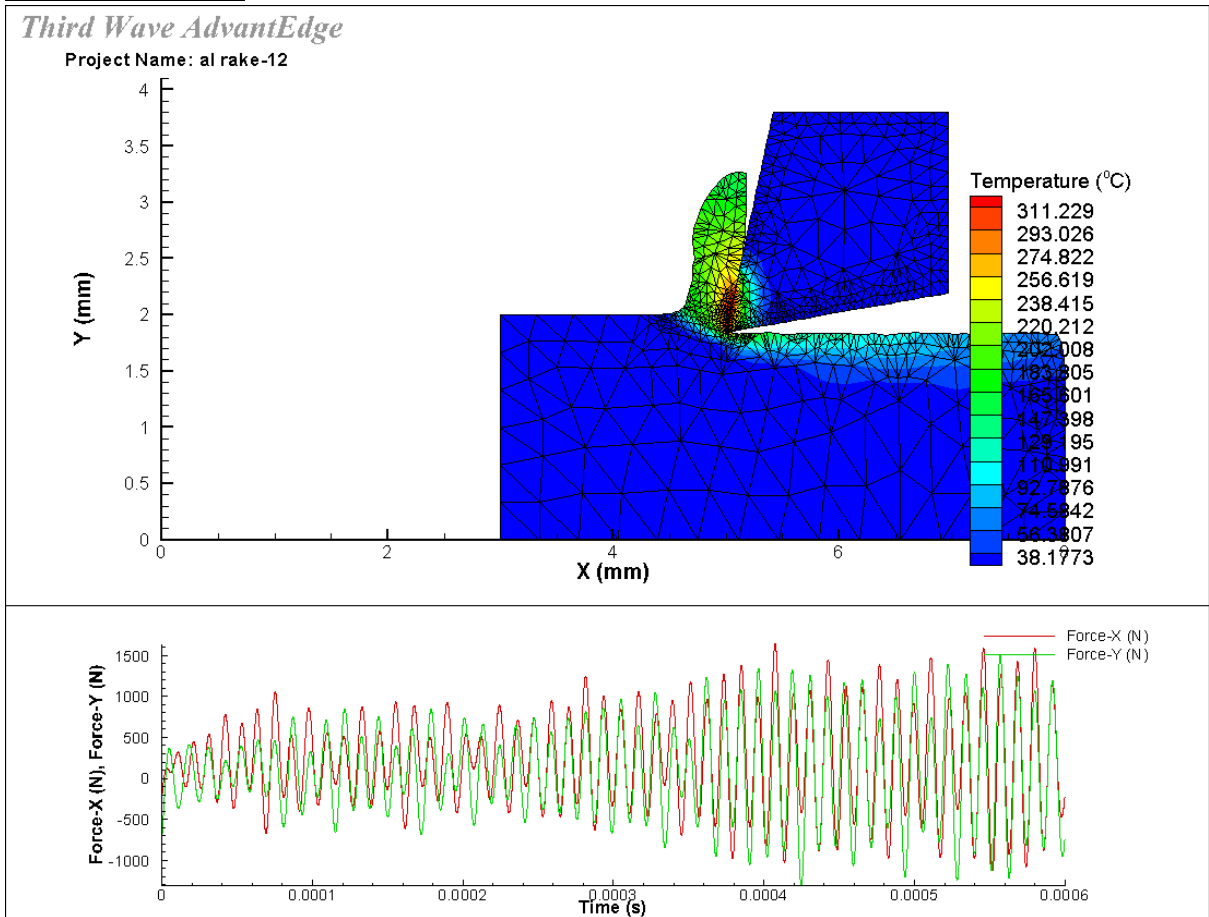

-- PROJECT --

Version = 7.1002
 Project / Job Name = **al rake-12**
 Project / Job Description =
 Units = SI
 Process Type = turning
 Workpiece Type = STANDARD
 Tool Type = STANDARD
 Tool Material Type = STANDARD

-- STANDARD WORKPIECE --

Workpiece length = 5.0 mm
 Workpiece height = 2.0 mm
Material = Al6061-T6

-- STANDARD TOOL --

Tool File = al rake-12.twt
 Tool Process Type = OBLIQUE
 Rake angle = **12.0 deg**
 Rake length = 2.0 mm
 Relief angle = **10.0 deg**
 Relief length = 2.0 mm
 Cutting Edge Radius = 0.02 mm
 Tool Material = **Carbide-Grade-K**
 Minimum Tool Element Size = 0.02 mm
 Maximum Tool Element Size = 0.1 mm
 Mesh Grading = 0.4
 Coating Layer No. = 0

-- PROCESS --

Feed = 0.15 mm
 Cutting speed = 300.0 m/min
 Depth of cut = 1.0 mm
 Length of cut = 3.0 mm
 Initial temperature = 20.0 degC
 Friction coefficient = Default
 Cutting mode = General
 External Coolant = OFF
 Internal Primary Coolant = OFF
 Internal Secondary Coolant = OFF

-- SIMULATION --

Simulation Mode = Demonstration
 Steady state analysis = 0
 Avg. Length of Cut Ratio = 10.0
 Chip breakage = 0
 Max. number of nodes = 24000
 Max Element Size = 0.1 mm
 Min Element Size = 0.02 mm
 Fraction of Radius = 0.6
 Fraction of Feed = 0.1
 Mesh Refine = 2
 Mesh Coarse = 6
 Output Frame = 30

Rake angle-13⁰

Third Wave AdvantEdge

Project Name: al rake-13

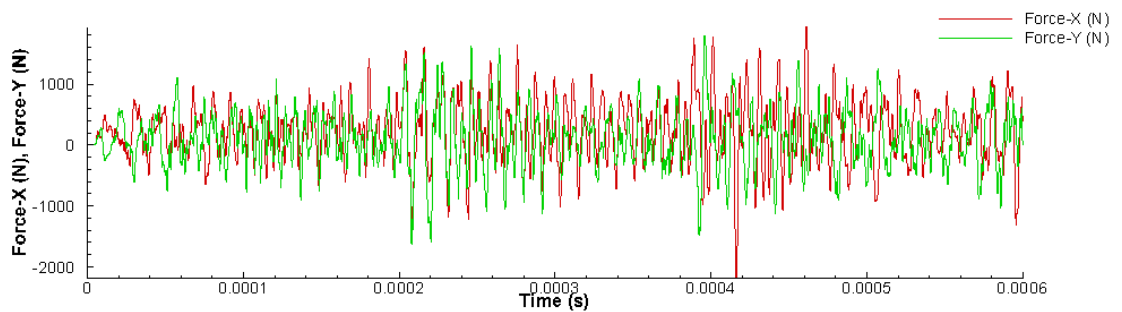
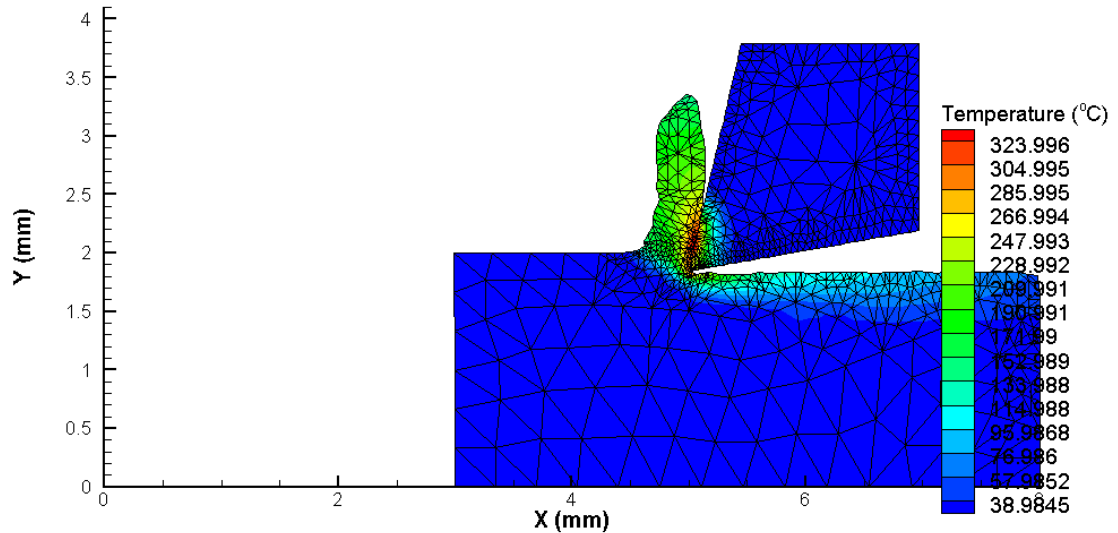

— PROJECT —

Version = 7.1002
 Project / Job Name = al rake-13
 Project / Job Description =
 Units = SI
 Process Type = turning
 Workpiece Type = STANDARD
 Tool Type = STANDARD
 Tool Material Type = STANDARD

— STANDARD WORKPIECE —

Workpiece length = 5.0 mm
 Workpiece height = 2.0 mm
 Material = Al6061-T6

— STANDARD TOOL —

Tool File = al rake-13.twt
 Tool Process Type = OBLIQUE
 Rake angle = 13.0 deg
 Rake length = 2.0 mm
 Relief angle = 10.0 deg
 Relief length = 2.0 mm
 Cutting Edge Radius = 0.02 mm
 Tool Material = Carbide-Grade-K
 Minimum Tool Element Size = 0.02 mm
 Maximum Tool Element Size = 0.1 mm
 Mesh Grading = 0.4
 Coating Layer No. = 0

— PROCESS —

Feed = 0.15 mm
 Cutting speed = 300.0 m/min
 Depth of cut = 1.0 mm
 Length of cut = 3.0 mm
 Initial temperature = 20.0 degC
 Friction coefficient = Default
 Cutting mode = General
 External Coolant = OFF
 Internal Primary Coolant = OFF
 Internal Secondary Coolant = OFF

— SIMULATION —

Simulation Mode = Demonstration
 Steady state analysis = 0
 Avg. Length of Cut Ratio = 10.0
 Chip breakage = 0
 Max. number of nodes = 24000
 Max Element Size = 0.1 mm
 Min Element Size = 0.02 mm
 Fraction of Radius = 0.6
 Fraction of Feed = 0.1
 Mesh Refine = 2
 Mesh Coarse = 6

Rake angle-14°

Third Wave AdvantEdge

Project Name: al rake-14

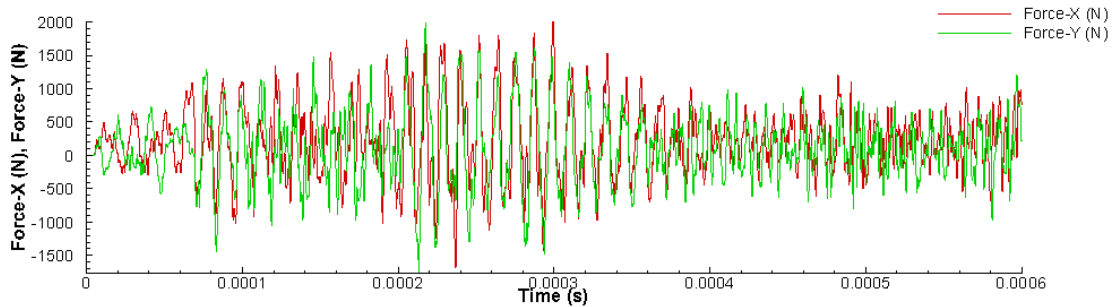
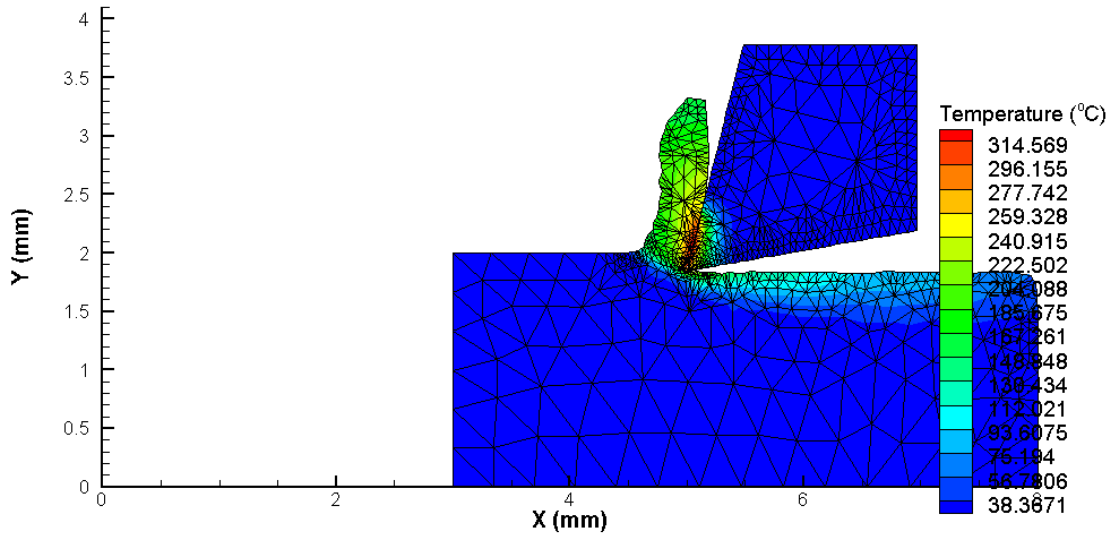

-- PROJECT --

Version = 7.1002
 Project / Job Name = al rake-14
 Project / Job Description =
 Units = SI
 Process Type = turning
 Workpiece Type = STANDARD
 Tool Type = STANDARD
 Tool Material Type = STANDARD

-- STANDARD WORKPIECE --

Workpiece length = 5.0 mm
 Workpiece height = 2.0 mm
 Material = Al6061-T6

-- STANDARD TOOL --

Tool File = al rake-14.twt
 Tool Process Type = OBLIQUE
 Rake angle = 14.0 deg
 Rake length = 2.0 mm
 Relief angle = 10.0 deg
 Relief length = 2.0 mm
 Cutting Edge Radius = 0.02 mm
 Tool Material = Carbide-Grade-K
 Minimum Tool Element Size = 0.02 mm
 Maximum Tool Element Size = 0.1 mm
 Mesh Grading = 0.4
 Coating Layer No. = 0

-- PROCESS --

Feed = 0.15 mm
 Cutting speed = 300.0 m/min
 Depth of cut = 1.0 mm
 Length of cut = 3.0 mm
 Initial temperature = 20.0 degC
 Friction coefficient = Default
 Cutting mode = General
 External Coolant = OFF
 Internal Primary Coolant = OFF
 Internal Secondary Coolant = OFF

-- SIMULATION --

Simulation Mode = Demonstration
 Steady state analysis = 0
 Avg. Length of Cut Ratio = 10.0
 Chip breakage = 0
 Max. number of nodes = 24000
 Max Element Size = 0.1 mm
 Min Element Size = 0.02 mm
 Fraction of Radius = 0.6
 Fraction of Feed = 0.1
 Mesh Refine = 2
 Mesh Coarse = 6
 Output Frame = 30

Rake angle-16°

Third Wave AdvantEdge

Project Name: al rake-16

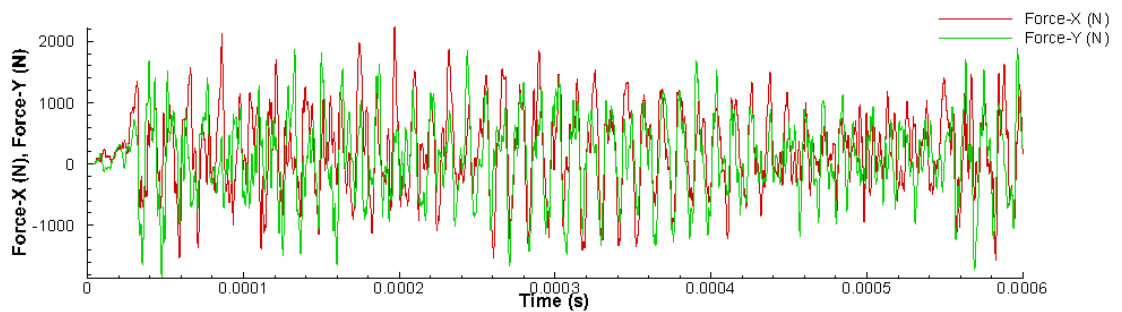
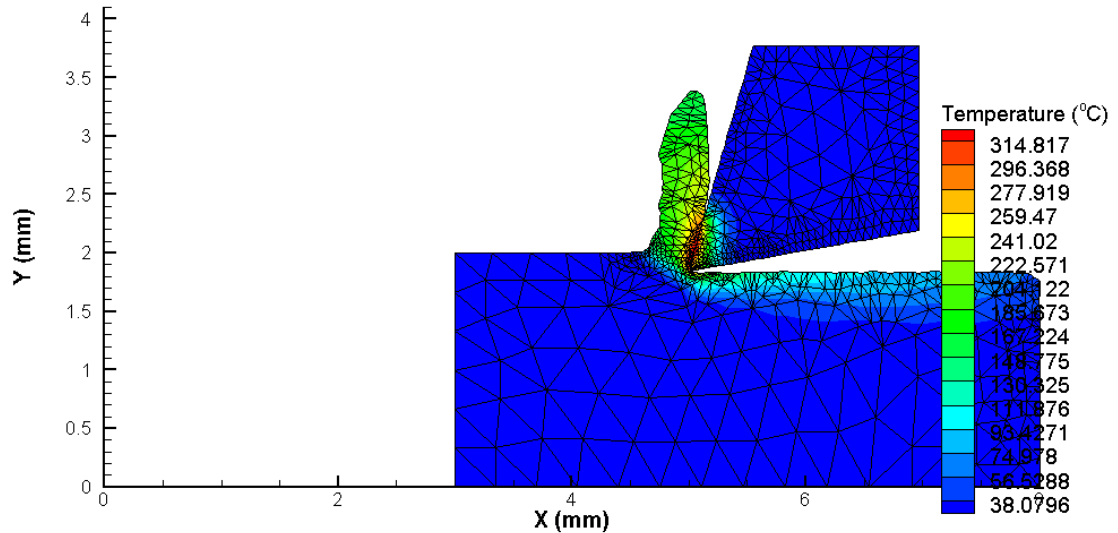

-- PROJECT --

Version = 7.1002
 Project / Job Name = al rake-16
 Project / Job Description =
 Units = SI
 Process Type = turning
 Workpiece Type = STANDARD
 Tool Type = STANDARD
 Tool Material Type = STANDARD

-- STANDARD WORKPIECE --

Workpiece length = 5.0 mm
 Workpiece height = 2.0 mm
 Material = Al6061-T6

-- STANDARD TOOL --

Tool File = al rake-16.twt
 Tool Process Type = OBLIQUE
 Rake angle = 16.0 deg
 Rake length = 2.0 mm
 Relief angle = 10.0 deg
 Relief length = 2.0 mm
 Cutting Edge Radius = 0.02 mm
 Tool Material = Carbide-Grade-K
 Minimum Tool Element Size = 0.02 mm
 Maximum Tool Element Size = 0.1 mm
 Mesh Grading = 0.4
 Coating Layer No. = 0

-- PROCESS --

Feed = 0.15 mm
 Cutting speed = 300.0 m/min
 Depth of cut = 1.0 mm
 Length of cut = 3.0 mm
 Initial temperature = 20.0 degC
 Friction coefficient = Default
 Cutting mode = General
 External Coolant = OFF
 Internal Primary Coolant = OFF
 Internal Secondary Coolant = OFF

-- SIMULATION --

Simulation Mode = Demonstration
 Steady state analysis = 0
 Avg. Length of Cut Ratio = 10.0
 Chip breakage = 0
 Max. number of nodes = 24000
 Max Element Size = 0.1 mm
 Min Element Size = 0.02 mm
 Fraction of Radius = 0.6
 Fraction of Feed = 0.1
 Mesh Refine = 2
 Mesh Coarse = 6
 Output Frame = 30

Rake angle-18°

Third Wave AdvantEdge

Project Name: al rake-18

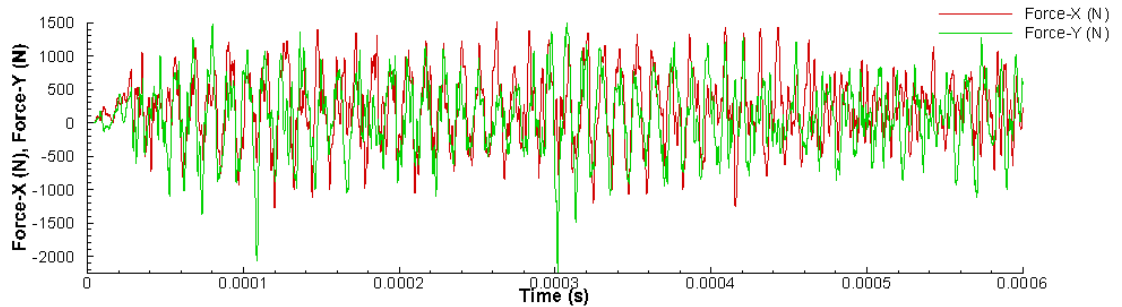
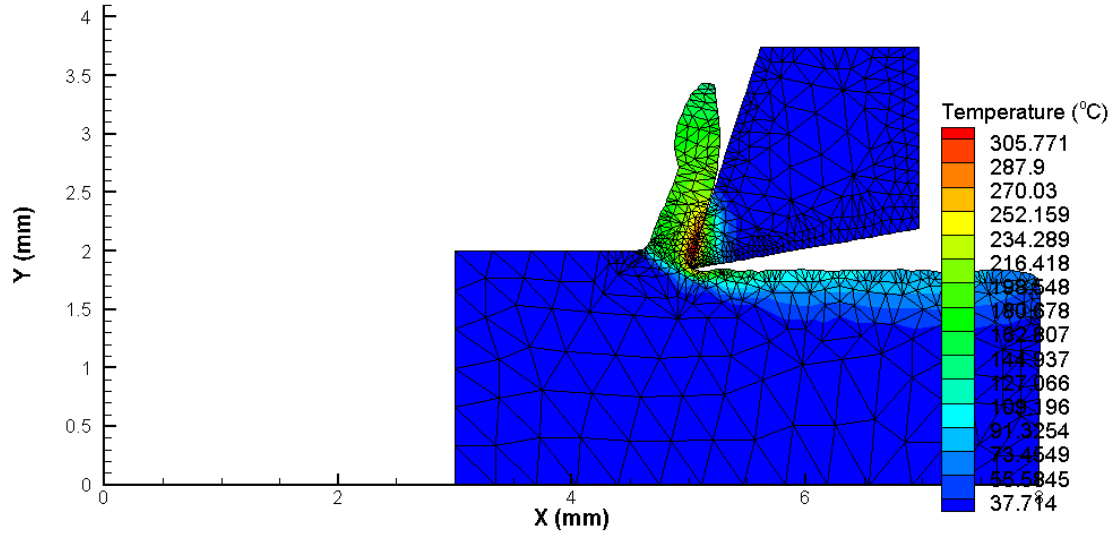

-- PROJECT --

Version = 7.1002
 Project / Job Name = al rake-18
 Project / Job Description =
 Units = SI
 Process Type = turning
 Workpiece Type = STANDARD
 Tool Type = STANDARD
 Tool Material Type = STANDARD

-- STANDARD WORKPIECE --

Workpiece length = 5.0 mm
 Workpiece height = 2.0 mm
 Material = Al6061-T6

-- STANDARD TOOL --

Tool File = al rake-18.twt
 Tool Process Type = OBLIQUE
 Rake angle = 18.0 deg
 Rake length = 2.0 mm
 Relief angle = 10.0 deg
 Relief length = 2.0 mm
 Cutting Edge Radius = 0.02 mm
 Tool Material = Carbide-Grade-K
 Minimum Tool Element Size = 0.02 mm
 Maximum Tool Element Size = 0.1 mm
 Mesh Grading = 0.4
 Coating Layer No. = 0

-- PROCESS --

Feed = 0.15 mm
 Cutting speed = 300.0 m/min
 Depth of cut = 1.0 mm
 Length of cut = 3.0 mm
 Initial temperature = 20.0 degC
 Friction coefficient = Default
 Cutting mode = General
 External Coolant = OFF
 Internal Primary Coolant = OFF
 Internal Secondary Coolant = OFF

-- SIMULATION --

Simulation Mode = Demonstration
 Steady state analysis = 0
 Avg. Length of Cut Ratio = 10.0
 Chip breakage = 0
 Max. number of nodes = 24000
 Max Element Size = 0.1 mm
 Min Element Size = 0.02 mm
 Fraction of Radius = 0.6
 Fraction of Feed = 0.1
 Mesh Refine = 2
 Mesh Coarse = 6
 Output Frame = 30

Rake angle-20°

Third Wave AdvantEdge

Project Name: al rake-20

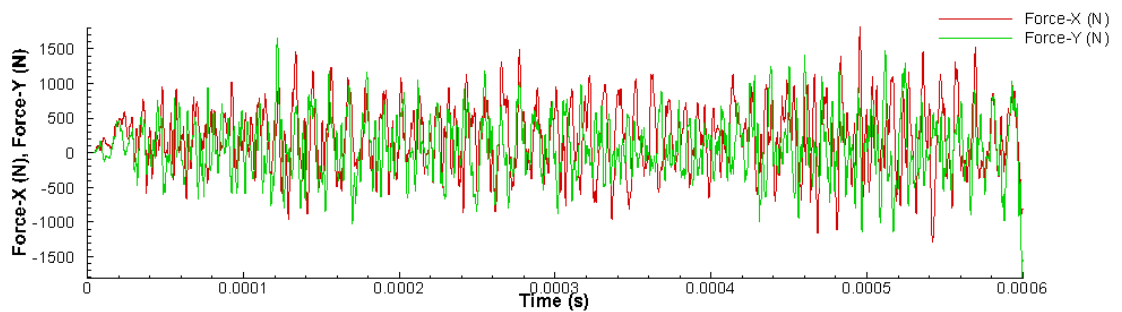
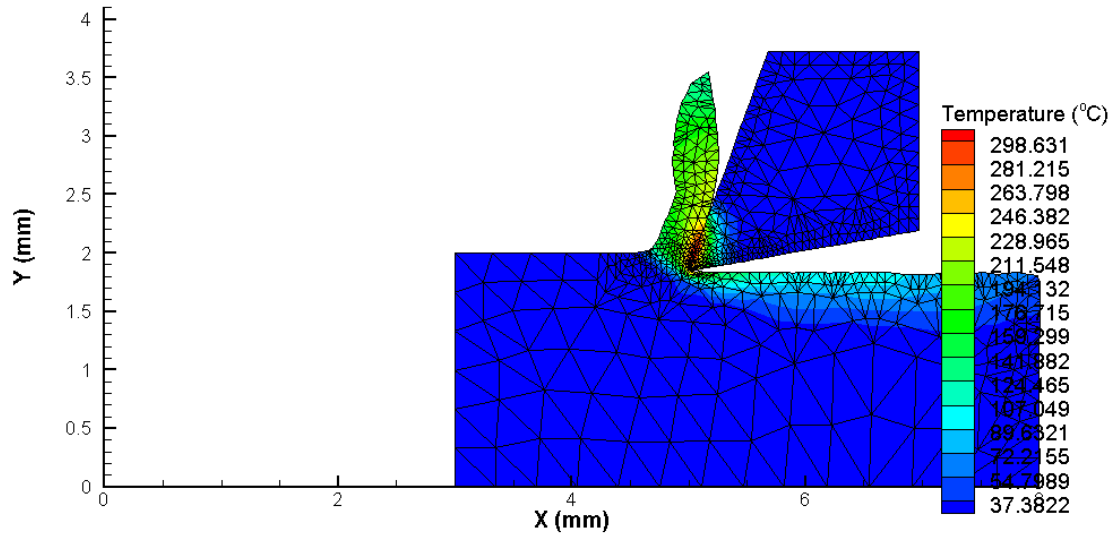

-- PROJECT --

Version = 7.1002
 Project / Job Name = al rake-20
 Project / Job Description =
 Units = SI
 Process Type = turning
 Workpiece Type = STANDARD
 Tool Type = STANDARD
 Tool Material Type = STANDARD

-- STANDARD WORKPIECE --

Workpiece length = 5.0 mm
 Workpiece height = 2.0 mm
 Material = Al6061-T6

-- STANDARD TOOL --

Tool File = al rake-20.twt
 Tool Process Type = OBLIQUE
 Rake angle = 20.0 deg
 Rake length = 2.0 mm
 Relief angle = 10.0 deg
 Relief length = 2.0 mm
 Cutting Edge Radius = 0.02 mm
 Tool Material = Carbide-Grade-K
 Minimum Tool Element Size = 0.02 mm
 Maximum Tool Element Size = 0.1 mm
 Mesh Grading = 0.4
 Coating Layer No. = 0

-- PROCESS --

Feed = 0.15 mm
 Cutting speed = 300.0 m/min
 Depth of cut = 1.0 mm
 Length of cut = 3.0 mm
 Initial temperature = 20.0 degC
 Friction coefficient = Default
 Cutting mode = General
 External Coolant = OFF
 Internal Primary Coolant = OFF
 Internal Secondary Coolant = OFF

-- SIMULATION --

Simulation Mode = Demonstration
 Steady state analysis = 0
 Avg. Length of Cut Ratio = 10.0
 Chip breakage = 0
 Max. number of nodes = 24000
 Max Element Size = 0.1 mm
 Min Element Size = 0.02 mm
 Fraction of Radius = 0.6
 Fraction of Feed = 0.1
 Mesh Refine = 2
 Mesh Coarse = 6
 Output Frame = 30

Rake angle-22°

Third Wave AdvantEdge

Project Name: al rake-22

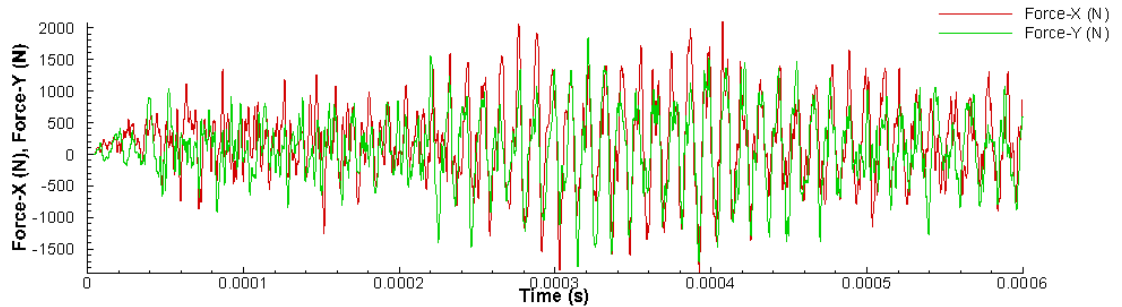
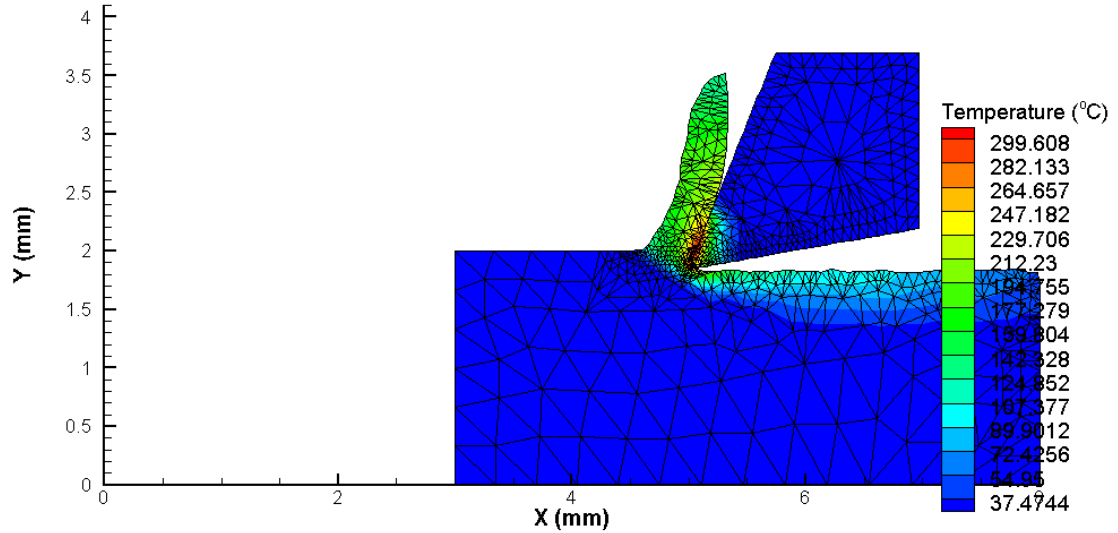

-- PROJECT --

Version = 7.1002
 Project / Job Name = al rake-22
 Project / Job Description =
 Units = SI
 Process Type = turning
 Workpiece Type = STANDARD
 Tool Type = STANDARD
 Tool Material Type = STANDARD

-- STANDARD WORKPIECE --

Workpiece length = 5.0 mm
 Workpiece height = 2.0 mm
 Material = Al6061-T6

-- STANDARD TOOL --

Tool File = al rake-22.twt
 Tool Process Type = OBLIQUE
 Rake angle = 22.0 deg
 Rake length = 2.0 mm
 Relief angle = 10.0 deg
 Relief length = 2.0 mm
 Cutting Edge Radius = 0.02 mm
 Tool Material = Carbide-Grade-K
 Minimum Tool Element Size = 0.02 mm
 Maximum Tool Element Size = 0.1 mm
 Mesh Grading = 0.4
 Coating Layer No. = 0

-- PROCESS --

Feed = 0.15 mm
 Cutting speed = 300.0 m/min
 Depth of cut = 1.0 mm
 Length of cut = 3.0 mm
 Initial temperature = 20.0 degC
 Friction coefficient = Default
 Cutting mode = General
 External Coolant = OFF
 Internal Primary Coolant = OFF
 Internal Secondary Coolant = OFF

-- SIMULATION --

Simulation Mode = Demonstration
 Steady state analysis = 0
 Avg. Length of Cut Ratio = 10.0
 Chip breakage = 0
 Max. number of nodes = 24000
 Max Element Size = 0.1 mm
 Min Element Size = 0.02 mm
 Fraction of Radius = 0.6
 Fraction of Feed = 0.1
 Mesh Refine = 2
 Mesh Coarse = 6
 Output Frame = 30

- **Aluminium(Al-6061)-**
Relief angle-8°

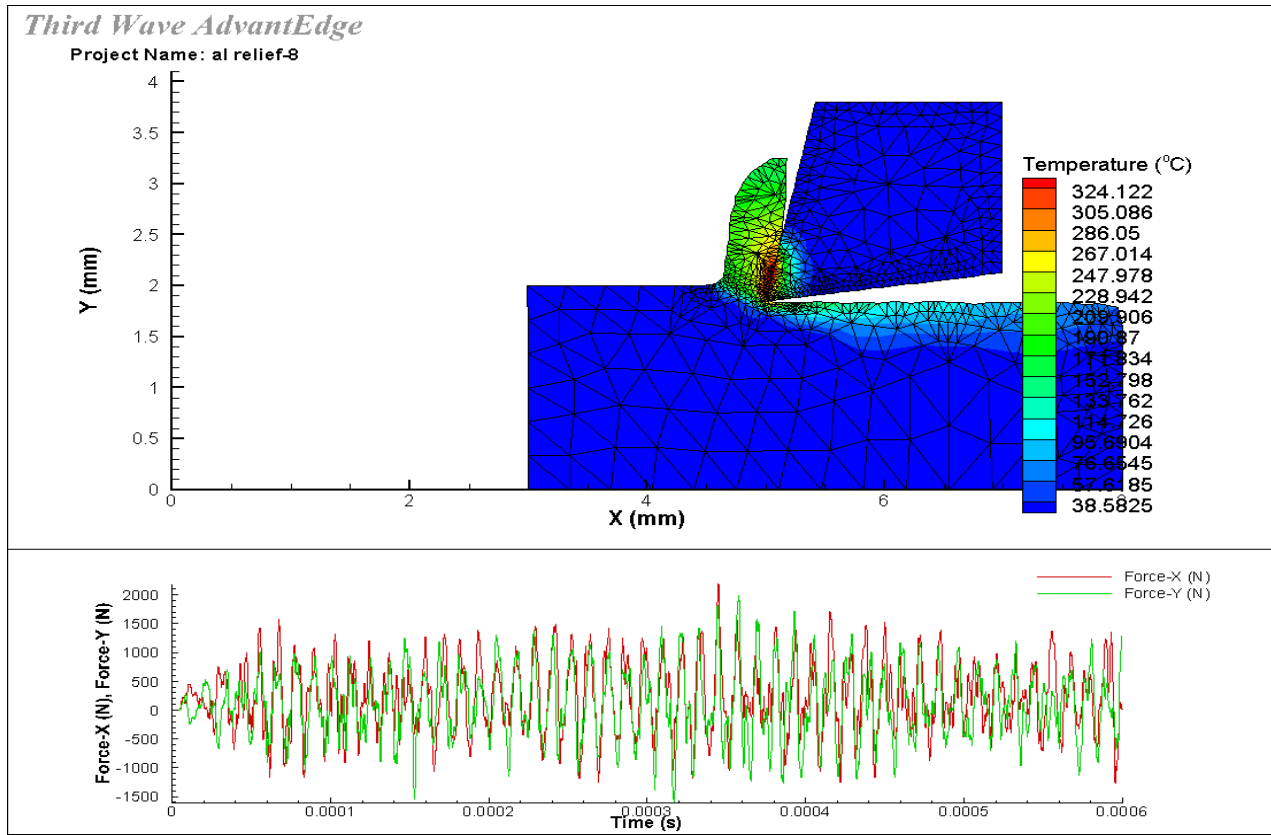

Version = 7.1002
Project / Job Name = al relief-8
Project / Job Description =
Units = SI
Process Type = turning
Workpiece Type = STANDARD
Tool Type = STANDARD
Tool Material Type = STANDARD

— STANDARD WORKPIECE —

Workpiece length = 5.0 mm
Workpiece height = 2.0 mm
Material = Al6061-T6

— STANDARD TOOL —

Tool File = al relief-8.twt
Tool Process Type = OBLIQUE
Rake angle = 12.0 deg
Rake length = 2.0 mm
Relief angle = 8.0 deg
Relief length = 2.0 mm
Cutting Edge Radius = 0.02 mm
Tool Material = Carbide-Grade-K
Minimum Tool Element Size = 0.02 mm
Maximum Tool Element Size = 0.1 mm
Mesh Grading = 0.4
Coating Layer No. = 0

— PROCESS —

Feed = 0.15 mm
Cutting speed = 300.0 m/min
Depth of cut = 1.0 mm
Length of cut = 3.0 mm
Initial temperature = 20.0 degC
Friction coefficient = Default
Cutting mode = General
External Coolant = OFF
Internal Primary Coolant = OFF
Internal Secondary Coolant = OFF

— SIMULATION —

Simulation Mode = Demonstration
Steady state analysis = 0
Avg. Length of Cut Ratio = 10.0
Chip breakage = 0
Max. number of nodes = 24000
Max Element Size = 0.1 mm
Min Element Size = 0.02 mm
Fraction of Radius = 0.6
Fraction of Feed = 0.1
Mesh Refine = 2
Mesh Coarse = 6
Output Frame = 30

Relief angle-9°

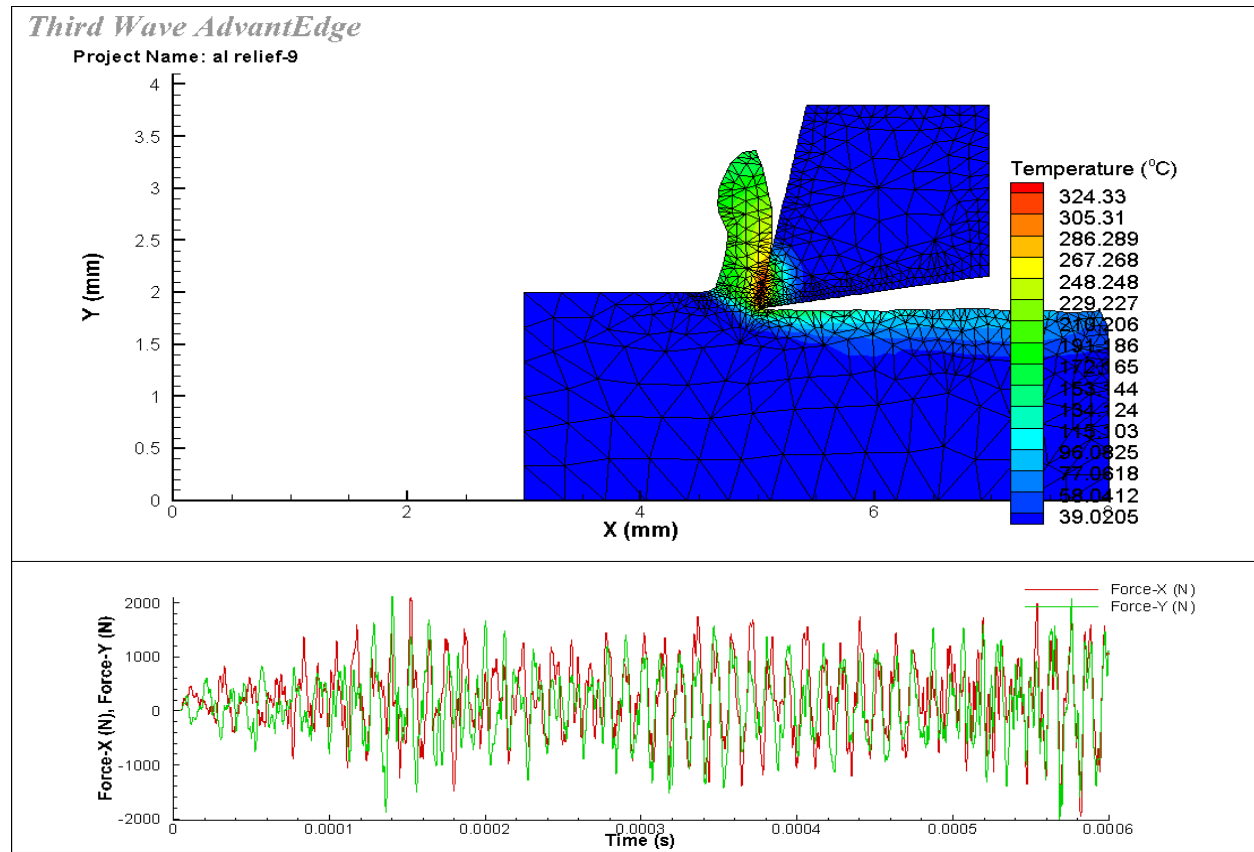

Version = 7.1002
Project / Job Name = al relief-9
Project / Job Description =
Units = SI
Process Type = turning
Workpiece Type = STANDARD
Tool Type = STANDARD
Tool Material Type = STANDARD

-- STANDARD WORKPIECE --

Workpiece length = 5.0 mm
Workpiece height = 2.0 mm
Material = Al6061-T6

-- STANDARD TOOL --

Tool File = al relief-9.twt
Tool Process Type = OBLIQUE
Rake angle = 12.0 deg
Rake length = 2.0 mm
Relief angle = 9.0 deg
Relief length = 2.0 mm
Cutting Edge Radius = 0.02 mm
Tool Material = Carbide-Grade-K
Minimum Tool Element Size = 0.02 mm
Maximum Tool Element Size = 0.1 mm
Mesh Grading = 0.4
Coating Layer No. = 0

-- PROCESS --

Feed = 0.15 mm
Cutting speed = 300.0 m/min
Depth of cut = 1.0 mm
Length of cut = 3.0 mm
Initial temperature = 20.0 degC
Friction coefficient = Default
Cutting mode = General
External Coolant = OFF
Internal Primary Coolant = OFF
Internal Secondary Coolant = OFF

-- SIMULATION --

Simulation Mode = Demonstration
Steady state analysis = 0
Avg. Length of Cut Ratio = 10.0
Chip breakage = 0
Max. number of nodes = 24000
Max Element Size = 0.1 mm
Min Element Size = 0.02 mm
Fraction of Radius = 0.6
Fraction of Feed = 0.1
Mesh Refine = 2
Mesh Coarse = 6
Output Frame = 30

Relief angle-10°

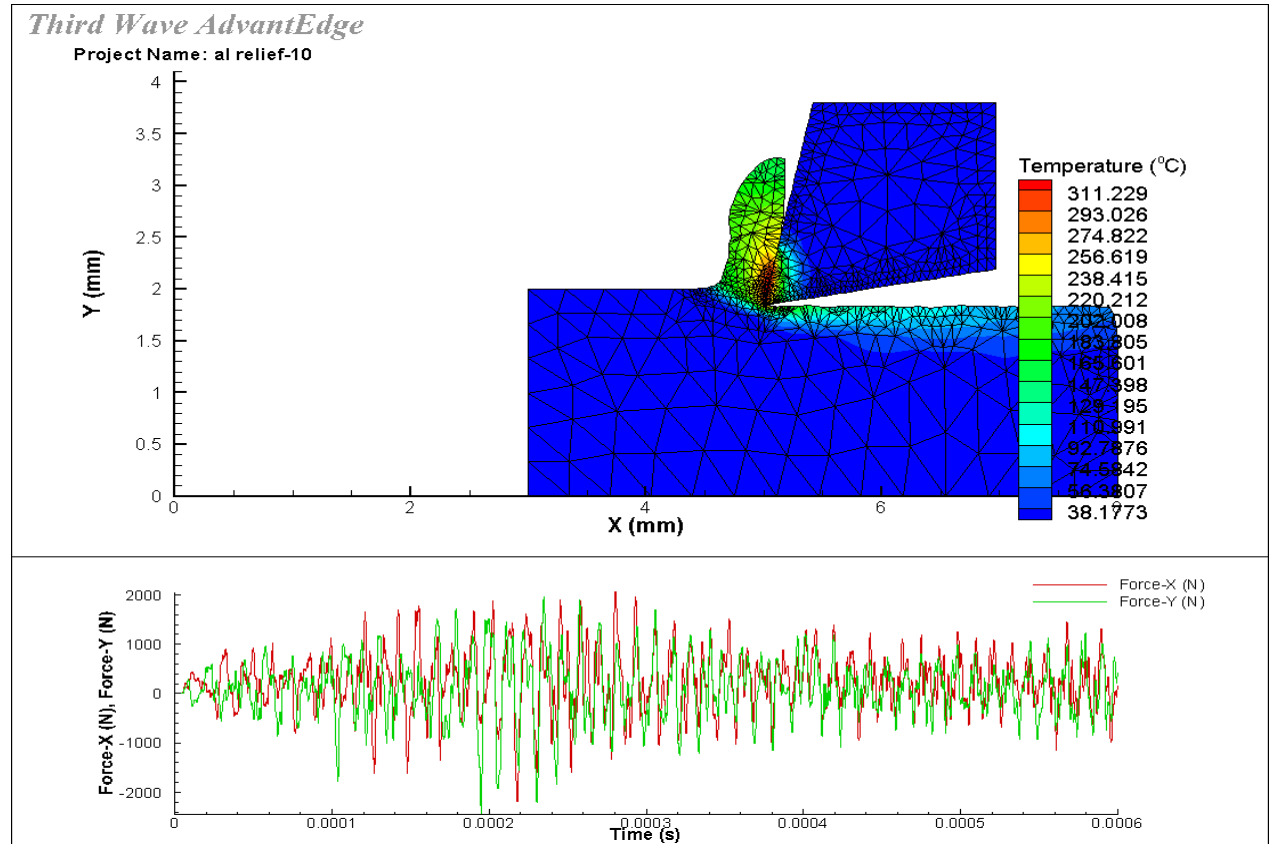

Version = 7.1002
Project / Job Name = al relief-10
Project / Job Description =
Units = SI
Process Type = turning
Workpiece Type = STANDARD
Tool Type = STANDARD
Tool Material Type = STANDARD

-- STANDARD WORKPIECE --

Workpiece length = 5.0 mm
Workpiece height = 2.0 mm
Material = Al6061-T6

-- STANDARD TOOL --

Tool File = al relief-10.twt
Tool Process Type = OBLIQUE
Rake angle = 12.0 deg
Rake length = 2.0 mm
Relief angle = 10.0 deg
Relief length = 2.0 mm
Cutting Edge Radius = 0.02 mm
Tool Material = Carbide-Grade-K
Minimum Tool Element Size = 0.02 mm
Maximum Tool Element Size = 0.1 mm
Mesh Grading = 0.4
Coating Layer No. = 0

-- PROCESS --

Feed = 0.15 mm
Cutting speed = 300.0 m/min
Depth of cut = 1.0 mm
Length of cut = 3.0 mm
Initial temperature = 20.0 degC
Friction coefficient = Default
Cutting mode = General
External Coolant = OFF
Internal Primary Coolant = OFF
Internal Secondary Coolant = OFF

-- SIMULATION --

Simulation Mode = Demonstration
Steady state analysis = 0
Avg. Length of Cut Ratio = 10.0
Chip breakage = 0
Max. number of nodes = 24000
Max Element Size = 0.1 mm
Min Element Size = 0.02 mm
Fraction of Radius = 0.6
Fraction of Feed = 0.1
Mesh Refine = 2
Mesh Coarse = 6
Output Frame = 30

Relief angle-11°

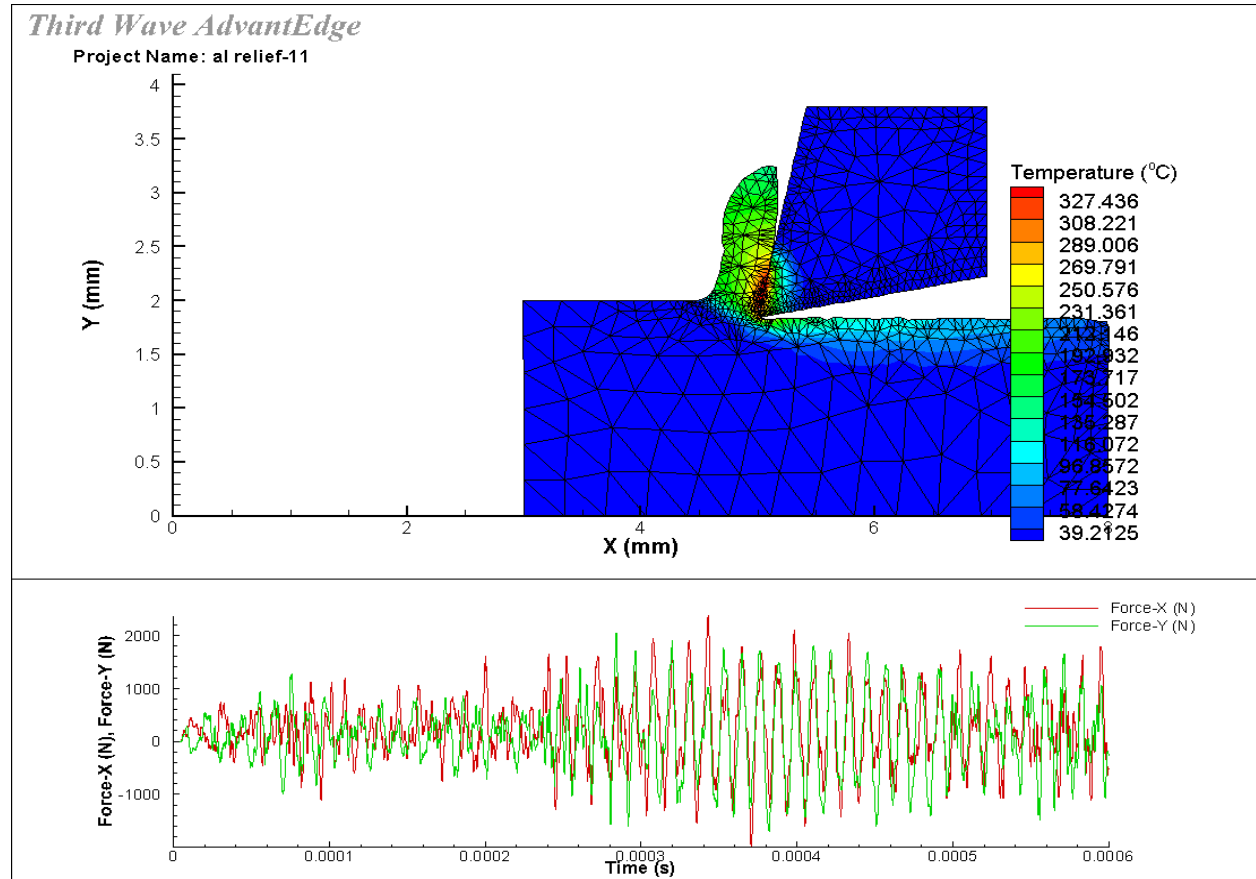

Version = 7.1002
 Project / Job Name = al relief-11
 Project / Job Description =
 Units = SI
 Process Type = turning
 Workpiece Type = STANDARD
 Tool Type = STANDARD
 Tool Material Type = STANDARD

-- STANDARD WORKPIECE --

Workpiece length = 5.0 mm
 Workpiece height = 2.0 mm
 Material = Al6061-T6

-- STANDARD TOOL --

Tool File = al relief-11.twt
 Tool Process Type = OBLIQUE
 Rake angle = 12.0 deg
 Rake length = 2.0 mm
 Relief angle = 11.0 deg
 Relief length = 2.0 mm
 Cutting Edge Radius = 0.02 mm
 Tool Material = Carbide-Grade-K
 Minimum Tool Element Size = 0.02 mm
 Maximum Tool Element Size = 0.1 mm
 Mesh Grading = 0.4
 Coating Layer No. = 0

-- PROCESS --

Feed = 0.15 mm
 Cutting speed = 300.0 m/min
 Depth of cut = 1.0 mm
 Length of cut = 3.0 mm
 Initial temperature = 20.0 degC
 Friction coefficient = Default
 Cutting mode = General
 External Coolant = OFF
 Internal Primary Coolant = OFF
 Internal Secondary Coolant = OFF

-- SIMULATION --

Simulation Mode = Demonstration
 Steady state analysis = 0
 Avg. Length of Cut Ratio = 10.0
 Chip breakage = 0
 Max. number of nodes = 24000
 Max Element Size = 0.1 mm
 Min Element Size = 0.02 mm
 Fraction of Radius = 0.6
 Fraction of Feed = 0.1
 Mesh Refine = 2
 Mesh Coarse = 6

Relief angle-12⁰

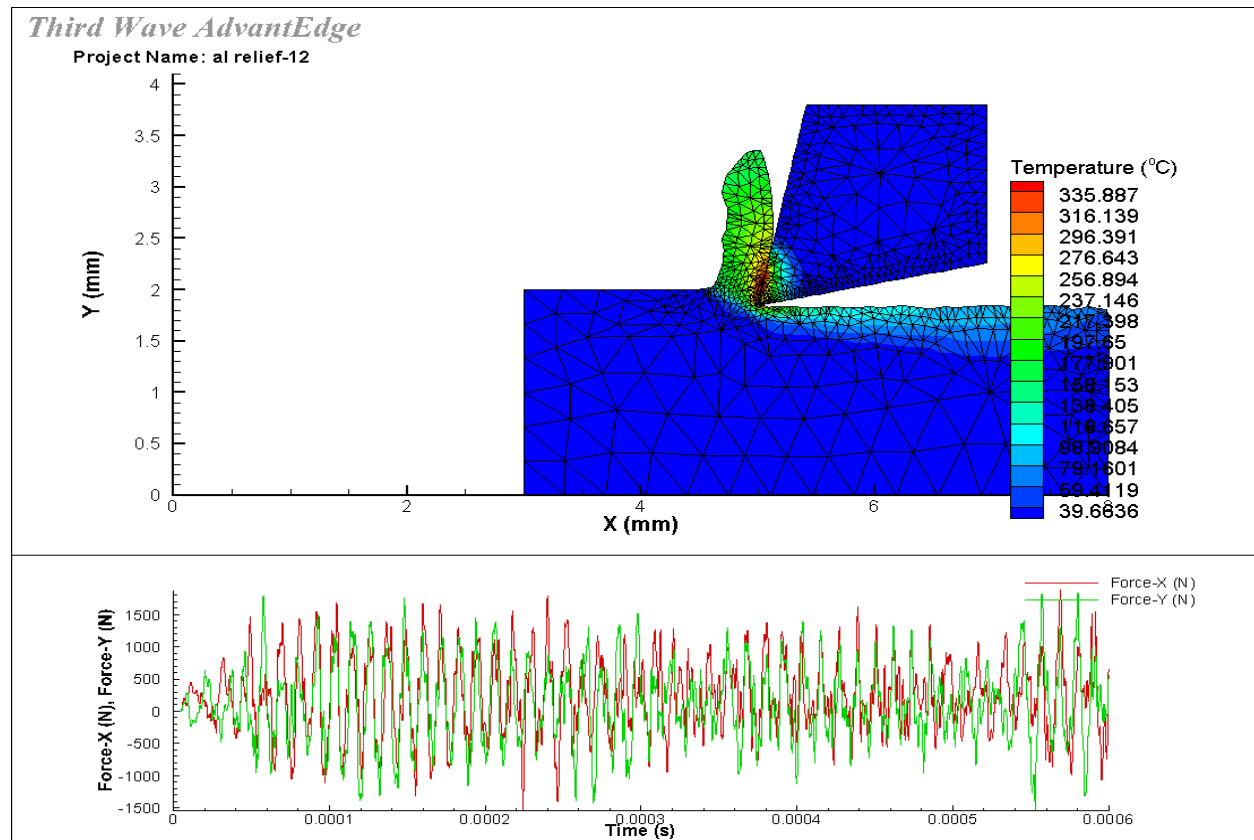

Version = 7.1002
Project / Job Name = al relief-12
Project / Job Description =
Units = SI
Process Type = turning
Workpiece Type = STANDARD
Tool Type = STANDARD
Tool Material Type = STANDARD

-- STANDARD WORKPIECE --

Workpiece length = 5.0 mm
Workpiece height = 2.0 mm
Material = Al6061-T6

-- STANDARD TOOL --

Tool File = al relief-12.twt
Tool Process Type = OBLIQUE
Rake angle = 12.0 deg
Rake length = 2.0 mm
Relief angle = 12.0 deg
Relief length = 2.0 mm
Cutting Edge Radius = 0.02 mm
Tool Material = Carbide-Grade-K
Minimum Tool Element Size = 0.02 mm
Maximum Tool Element Size = 0.1 mm
Mesh Grading = 0.4
Coating Layer No. = 0

-- PROCESS --

Feed = 0.15 mm
Cutting speed = 300.0 m/min
Depth of cut = 1.0 mm
Length of cut = 3.0 mm
Initial temperature = 20.0 degC
Friction coefficient = Default
Cutting mode = General
External Coolant = OFF
Internal Primary Coolant = OFF
Internal Secondary Coolant = OFF

-- SIMULATION --

Simulation Mode = Demonstration
Steady state analysis = 0
Avg. Length of Cut Ratio = 10.0
Chip breakage = 0
Max. number of nodes = 24000
Max Element Size = 0.1 mm
Min Element Size = 0.02 mm
Fraction of Radius = 0.6
Fraction of Feed = 0.1
Mesh Refine = 2
Mesh Coarse = 6
Output Frame = 30
Number of Threads = 1

Relief angle-13⁰

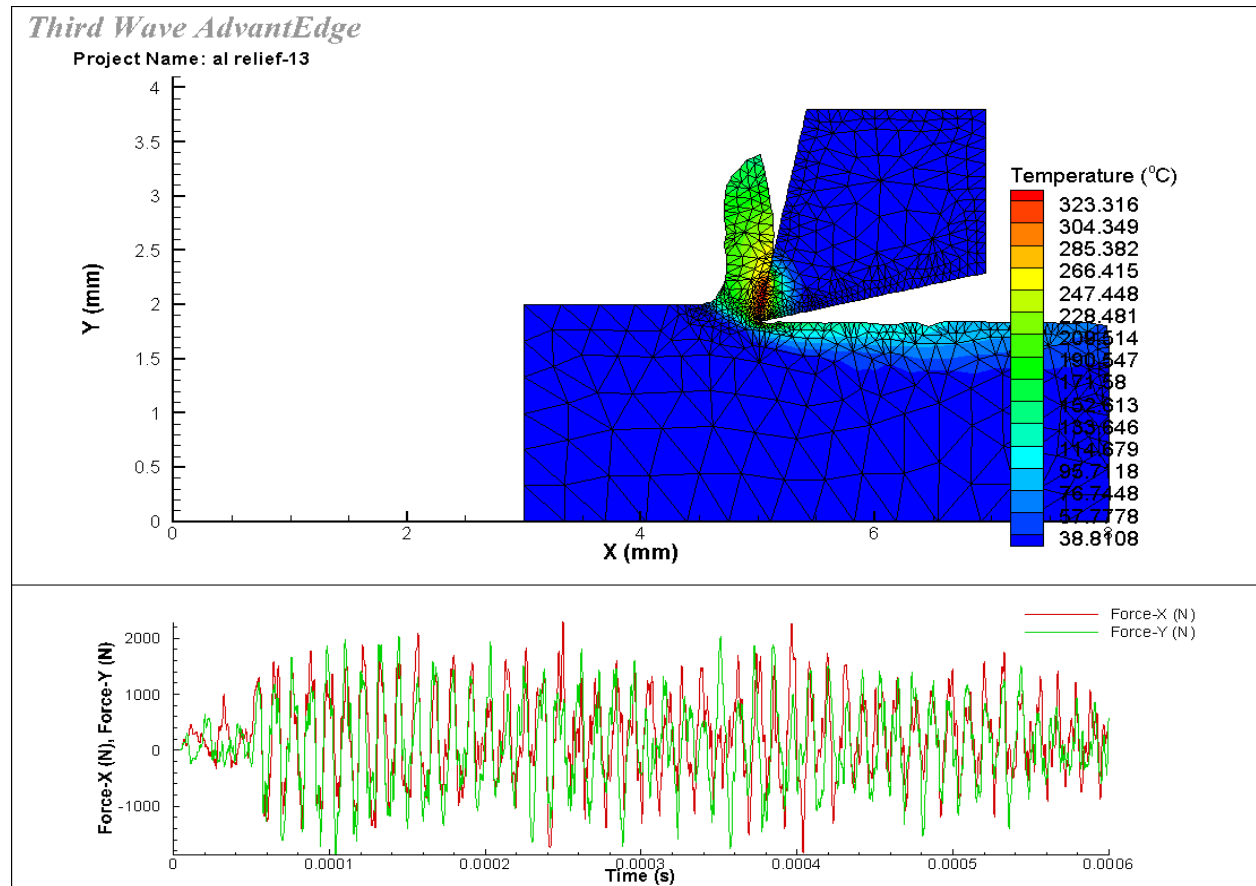

Version = 7.1002
Project / Job Name = al relief-13
Project / Job Description =
Units = SI
Process Type = turning
Workpiece Type = STANDARD
Tool Type = STANDARD
Tool Material Type = STANDARD

-- STANDARD WORKPIECE --

Workpiece length = 5.0 mm
Workpiece height = 2.0 mm
Material = Al6061-T6

-- STANDARD TOOL --

Tool File = al relief-13.twt
Tool Process Type = OBLIQUE
Rake angle = 12.0 deg
Rake length = 2.0 mm
Relief angle = 13.0 deg
Relief length = 2.0 mm
Cutting Edge Radius = 0.02 mm
Tool Material = Carbide-Grade-K
Minimum Tool Element Size = 0.02 mm
Maximum Tool Element Size = 0.1 mm
Mesh Grading = 0.4
Coating Layer No. = 0

-- PROCESS --

Feed = 0.15 mm
Cutting speed = 300.0 m/min
Depth of cut = 1.0 mm
Length of cut = 3.0 mm
Initial temperature = 20.0 degC
Friction coefficient = Default
Cutting mode = General
External Coolant = OFF
Internal Primary Coolant = OFF
Internal Secondary Coolant = OFF

-- SIMULATION --

Simulation Mode = Demonstration
Steady state analysis = 0
Avg. Length of Cut Ratio = 10.0
Chip breakage = 0
Max. number of nodes = 24000
Max Element Size = 0.1 mm
Min Element Size = 0.02 mm
Fraction of Radius = 0.6
Fraction of Feed = 0.1
Mesh Refine = 2
Mesh Coarse = 6
Output Frame = 30
Number of Threads = 1

Relief angle-14⁰

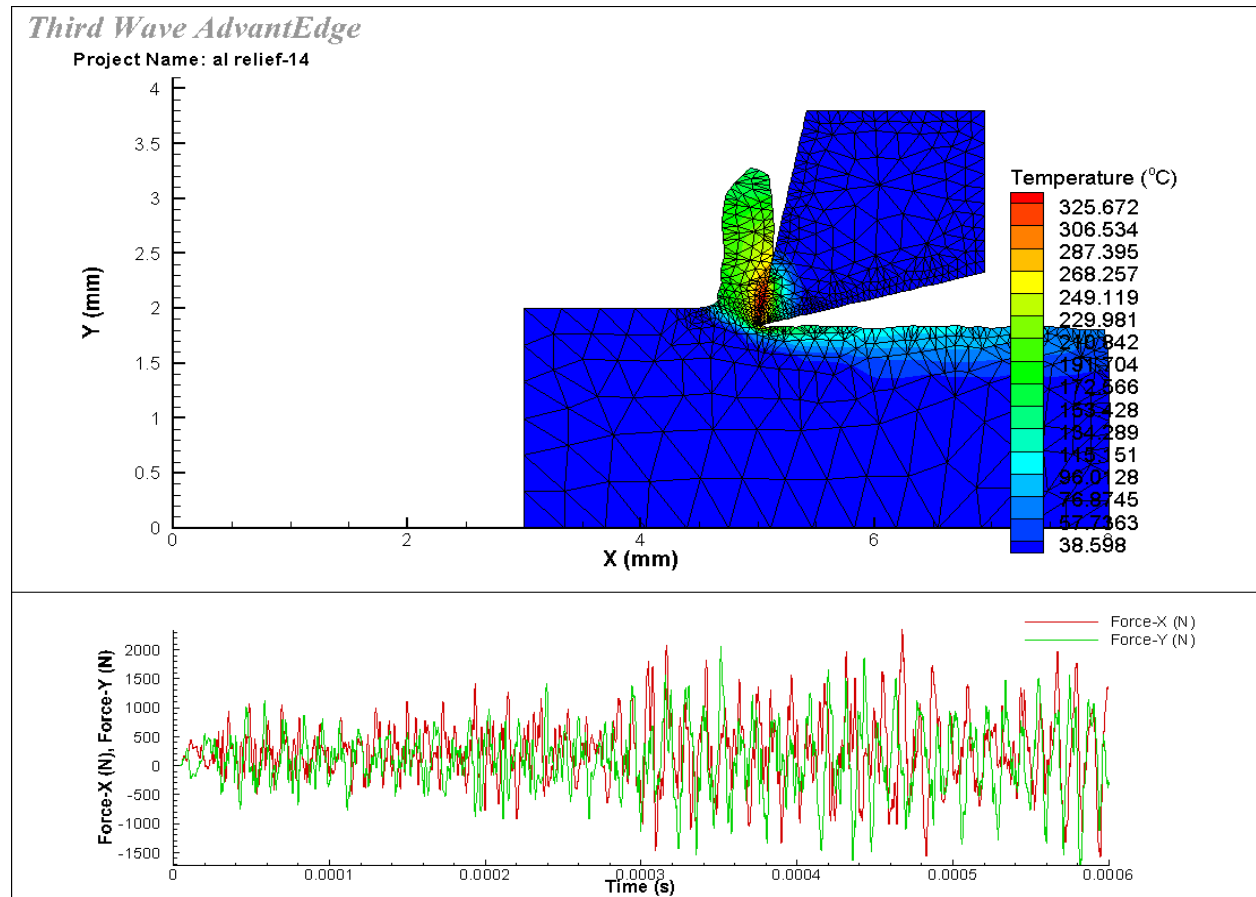

Version = 7.1002
Project / Job Name = al relief-14
Project / Job Description =
Units = SI
Process Type = turning
Workpiece Type = STANDARD
Tool Type = STANDARD
Tool Material Type = STANDARD

— STANDARD WORKPIECE —

Workpiece length = 5.0 mm
Workpiece height = 2.0 mm
Material = Al6061-T6

— STANDARD TOOL —

Tool File = al relief-14.twt
Tool Process Type = OBLIQUE
Rake angle = 12.0 deg
Rake length = 2.0 mm
Relief angle = 14.0 deg
Relief length = 2.0 mm
Cutting Edge Radius = 0.02 mm
Tool Material = Carbide-Grade-K
Minimum Tool Element Size = 0.02 mm
Maximum Tool Element Size = 0.1 mm
Mesh Grading = 0.4
Coating Layer No. = 0

— PROCESS —

Feed = 0.15 mm
Cutting speed = 300.0 m/min
Depth of cut = 1.0 mm
Length of cut = 3.0 mm
Initial temperature = 20.0 degC
Friction coefficient = Default
Cutting mode = General
External Coolant = OFF
Internal Primary Coolant = OFF
Internal Secondary Coolant = OFF

— SIMULATION —

Simulation Mode = Demonstration
Steady state analysis = 0
Avg. Length of Cut Ratio = 10.0
Chip breakage = 0
Max. number of nodes = 24000
Max Element Size = 0.1 mm
Min Element Size = 0.02 mm
Fraction of Radius = 0.6
Fraction of Feed = 0.1
Mesh Refine = 2
Mesh Coarse = 6
Output Frame = 30
Number of Threads = 1

- **Cast Iron(J431 G1800)-**
Rake angle-1°

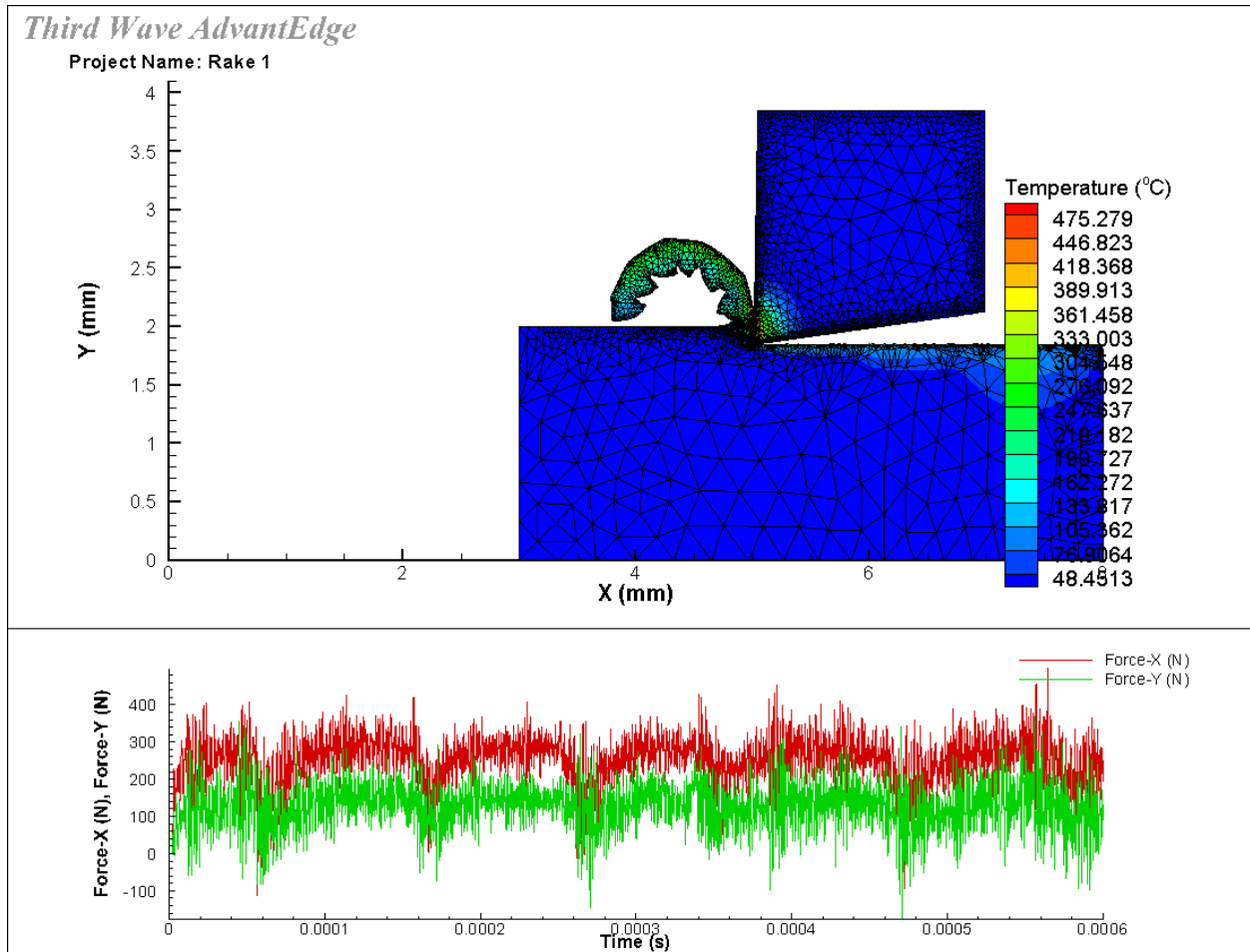

```

-- PROJECT --
Version = 7.1002
Project / Job Name = Rake 1
Project / Job Description =
Units = SI
Process Type = turning
Workpiece Type = STANDARD
Tool Type = STANDARD
Tool Material Type = STANDARD

-- STANDARD WORKPIECE --
Workpiece length = 5.0 mm
Workpiece height = 2.0 mm
Material = J431 G1800

-- STANDARD TOOL --
Tool File = Rake 1.twt
Tool Process Type = OBLIQUE
Rake angle = 1.0 deg
Rake length = 2.0 mm
Relief angle = 8.0 deg
Relief length = 2.0 mm
Cutting Edge Radius = 0.02 mm
Tool Material = Carbide-General
Minimum Tool Element Size = 0.02 mm
Maximum Tool Element Size = 0.1 mm
Mesh Grading = 0.4
Coating Layer No. = 0

-- PROCESS --
Feed = 0.15 mm
Cutting speed = 300.0 m/min
Depth of cut = 1.0 mm
Length of cut = 3.0 mm
Initial temperature = 20.0 degC
Friction coefficient = Default
Cutting mode = General
External Coolant = OFF
Internal Primary Coolant = OFF
Internal Secondary Coolant = OFF

-- SIMULATION --
Simulation Mode = Standard
Steady state analysis = 0
Avg. Length of Cut Ratio = 10.0
Chip breakage = 0
Max. number of nodes = 24000
Max Element Size = 0.1 mm
Min Element Size = 0.02 mm
Fraction of Radius = 0.6
Fraction of Feed = 0.1
Mesh Refine = 2
Mesh Coarse = 6
Output Frame = 30

```

Rake angle-2⁰

Third Wave AdvantEdge

Project Name: Rake 2

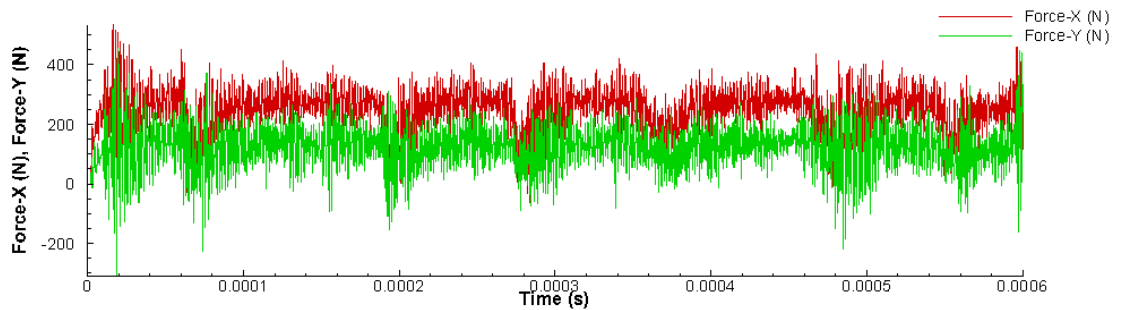
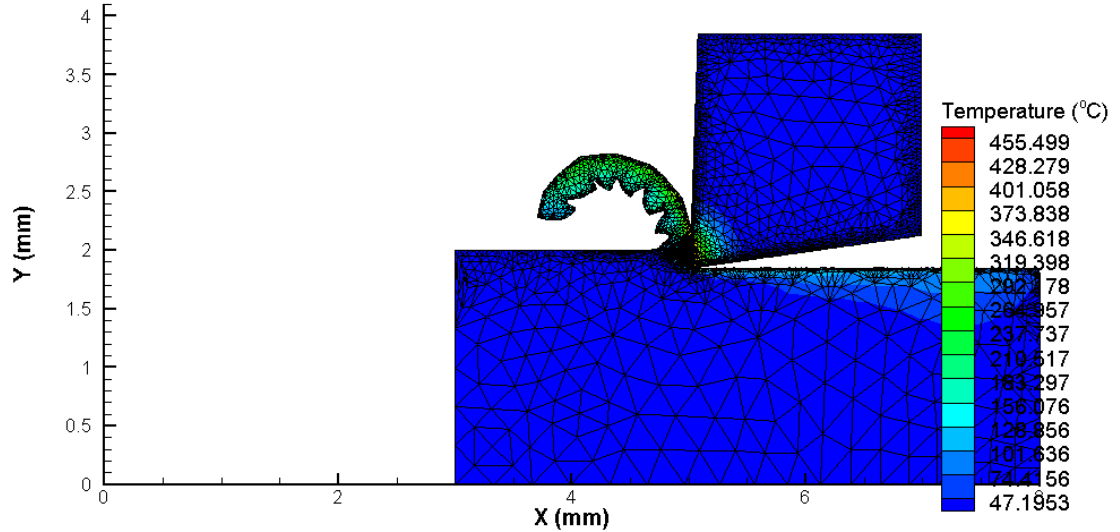

-- PROJECT --

Version = 7.1002
 Project / Job Name = Rake 2
 Project / Job Description =
 Units = SI
 Process Type = turning
 Workpiece Type = STANDARD
 Tool Type = STANDARD
 Tool Material Type = STANDARD

-- STANDARD WORKPIECE --

Workpiece length = 5.0 mm
 Workpiece height = 2.0 mm
 Material = J431 G1800

-- STANDARD TOOL --

Tool File = Rake 2.twt
 Tool Process Type = OBLIQUE
 Rake angle = 2.0 deg
 Rake length = 2.0 mm
 Relief angle = 8.0 deg
 Relief length = 2.0 mm
 Cutting Edge Radius = 0.02 mm
 Tool Material = Carbide-General
 Minimum Tool Element Size = 0.02 mm
 Maximum Tool Element Size = 0.1 mm
 Mesh Grading = 0.4
 Coating Layer No. = 0

-- PROCESS --

Feed = 0.15 mm
 Cutting speed = 300.0 m/min
 Depth of cut = 1.0 mm
 Length of cut = 3.0 mm
 Initial temperature = 20.0 degC
 Friction coefficient = Default
 Cutting mode = General
 External Coolant = OFF
 Internal Primary Coolant = OFF
 Internal Secondary Coolant = OFF

-- SIMULATION --

Simulation Mode = Standard
 Steady state analysis = 0
 Avg. Length of Cut Ratio = 10.0
 Chip breakage = 0
 Max. number of nodes = 24000
 Max Element Size = 0.1 mm
 Min Element Size = 0.02 mm
 Fraction of Radius = 0.6
 Fraction of Feed = 0.1
 Mesh Refine = 2
 Mesh Coarse = 6
 Output Frame = 30
 Number of Threads = 1

Rake angle-3⁰

Third Wave AdvantEdge

Project Name: Rake 3

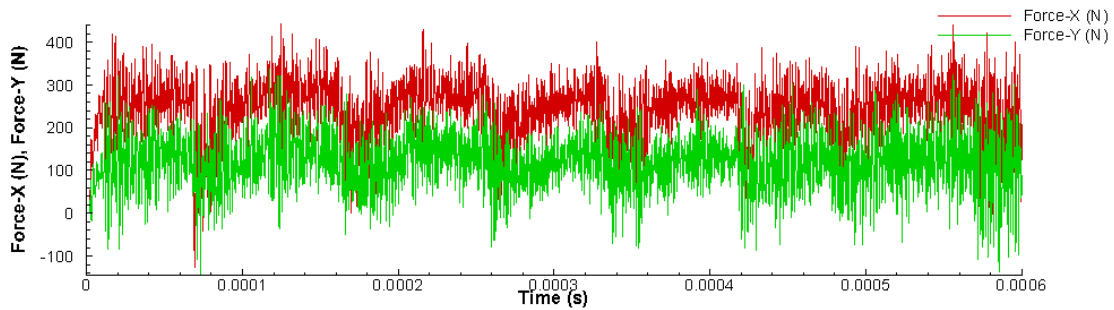
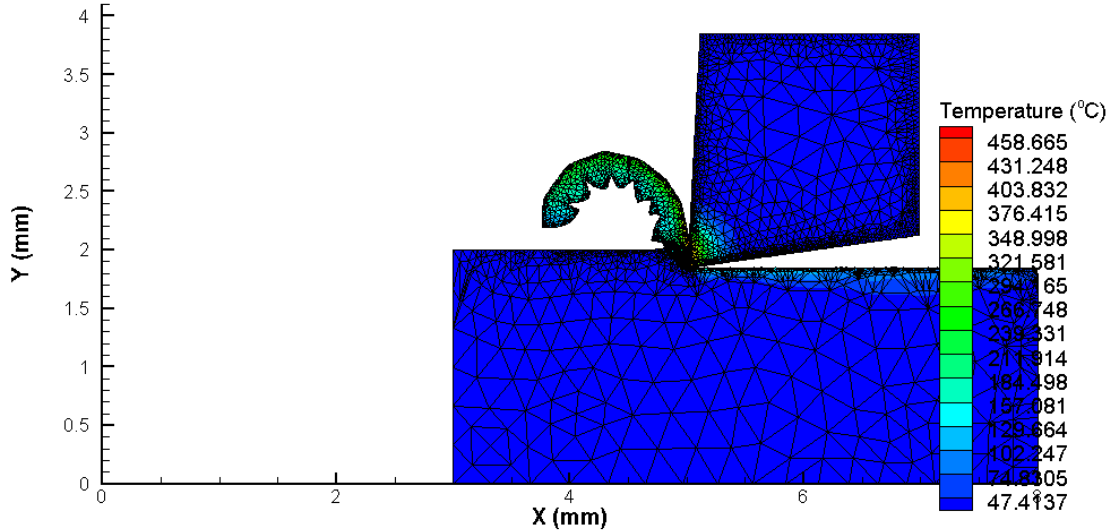

-- PROJECT --

Version = 7.1002
 Project / Job Name = Rake 3
 Project / Job Description =
 Units = SI
 Process Type = turning
 Workpiece Type = STANDARD
 Tool Type = STANDARD
 Tool Material Type = STANDARD

-- STANDARD WORKPIECE --

Workpiece length = 5.0 mm
 Workpiece height = 2.0 mm
 Material = **J431 G1800**

-- STANDARD TOOL --

Tool File = Rake 3.twt
 Tool Process Type = OBLIQUE
 Rake angle = **3.0 deg**
 Rake length = 2.0 mm
 Relief angle = 8.0 deg
 Relief length = 2.0 mm
 Cutting Edge Radius = 0.02 mm
 Tool Material = Carbide-General
 Minimum Tool Element Size = 0.02 mm
 Maximum Tool Element Size = 0.1 mm
 Mesh Grading = 0.4
 Coating Layer No. = 0

-- PROCESS --

Feed = 0.15 mm
 Cutting speed = 300.0 m/min
 Depth of cut = 1.0 mm
 Length of cut = 3.0 mm
 Initial temperature = 20.0 degC
 Friction coefficient = Default
 Cutting mode = General
 External Coolant = OFF
 Internal Primary Coolant = OFF
 Internal Secondary Coolant = OFF

-- SIMULATION --

Simulation Mode = Standard
 Steady state analysis = 0
 Avg. Length of Cut Ratio = 10.0
 Chip breakage = 0
 Max. number of nodes = 24000
 Max Element Size = 0.1 mm
 Min Element Size = 0.02 mm
 Fraction of Radius = 0.6
 Fraction of Feed = 0.1
 Mesh Refine = 2
 Mesh Coarse = 6
 Output Frame = 30

Rake angle-4°

Third Wave AdvantEdge

Project Name: Rake 4

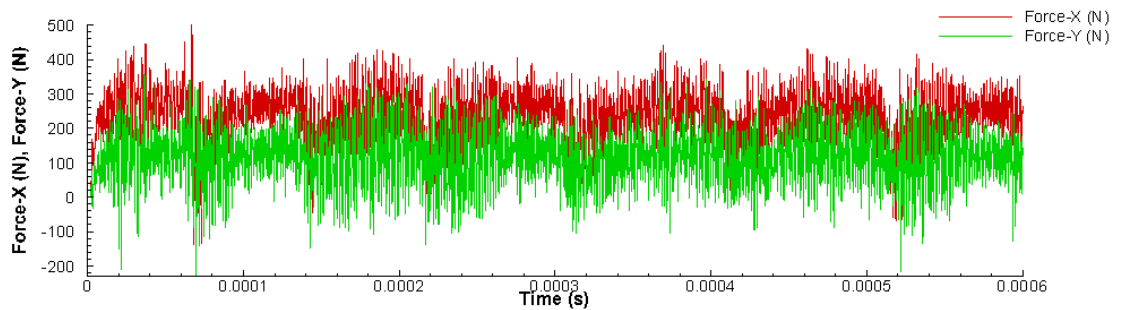
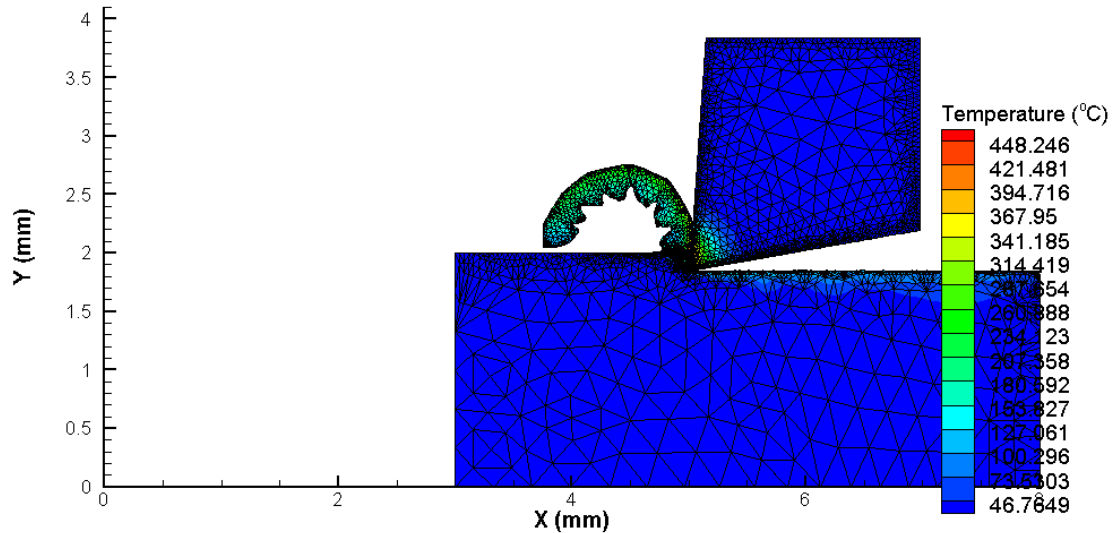

-- PROJECT --

Version = 7.1002
 Project / Job Name = Rake 4
 Project / Job Description =
 Units = SI
 Process Type = turning
 Workpiece Type = STANDARD
 Tool Type = STANDARD
 Tool Material Type = STANDARD

-- STANDARD WORKPIECE --

Workpiece length = 5.0 mm
 Workpiece height = 2.0 mm
 Material = J431 G1800

-- STANDARD TOOL --

Tool File = Rake 4.twt
 Tool Process Type = OBLIQUE
 Rake angle = 4.0 deg
 Rake length = 2.0 mm
 Relief angle = 10.0 deg
 Relief length = 2.0 mm
 Cutting Edge Radius = 0.02 mm
 Tool Material = Carbide-General
 Minimum Tool Element Size = 0.02 mm
 Maximum Tool Element Size = 0.1 mm
 Mesh Grading = 0.4
 Coating Layer No. = 0

-- PROCESS --

Feed = 0.15 mm
 Cutting speed = 300.0 m/min
 Depth of cut = 1.0 mm
 Length of cut = 3.0 mm
 Initial temperature = 20.0 degC
 Friction coefficient = Default
 Cutting mode = General
 External Coolant = OFF
 Internal Primary Coolant = OFF
 Internal Secondary Coolant = OFF

-- SIMULATION --

Simulation Mode = Standard
 Steady state analysis = 0
 Avg. Length of Cut Ratio = 10.0
 Chip breakage = 0
 Max. number of nodes = 24000
 Max Element Size = 0.1 mm
 Min Element Size = 0.02 mm
 Fraction of Radius = 0.6
 Fraction of Feed = 0.1
 Mesh Refine = 2
 Mesh Coarse = 6
 Output Frame = 30

- **Stainless Steel(304L)**
Rake angle-8°

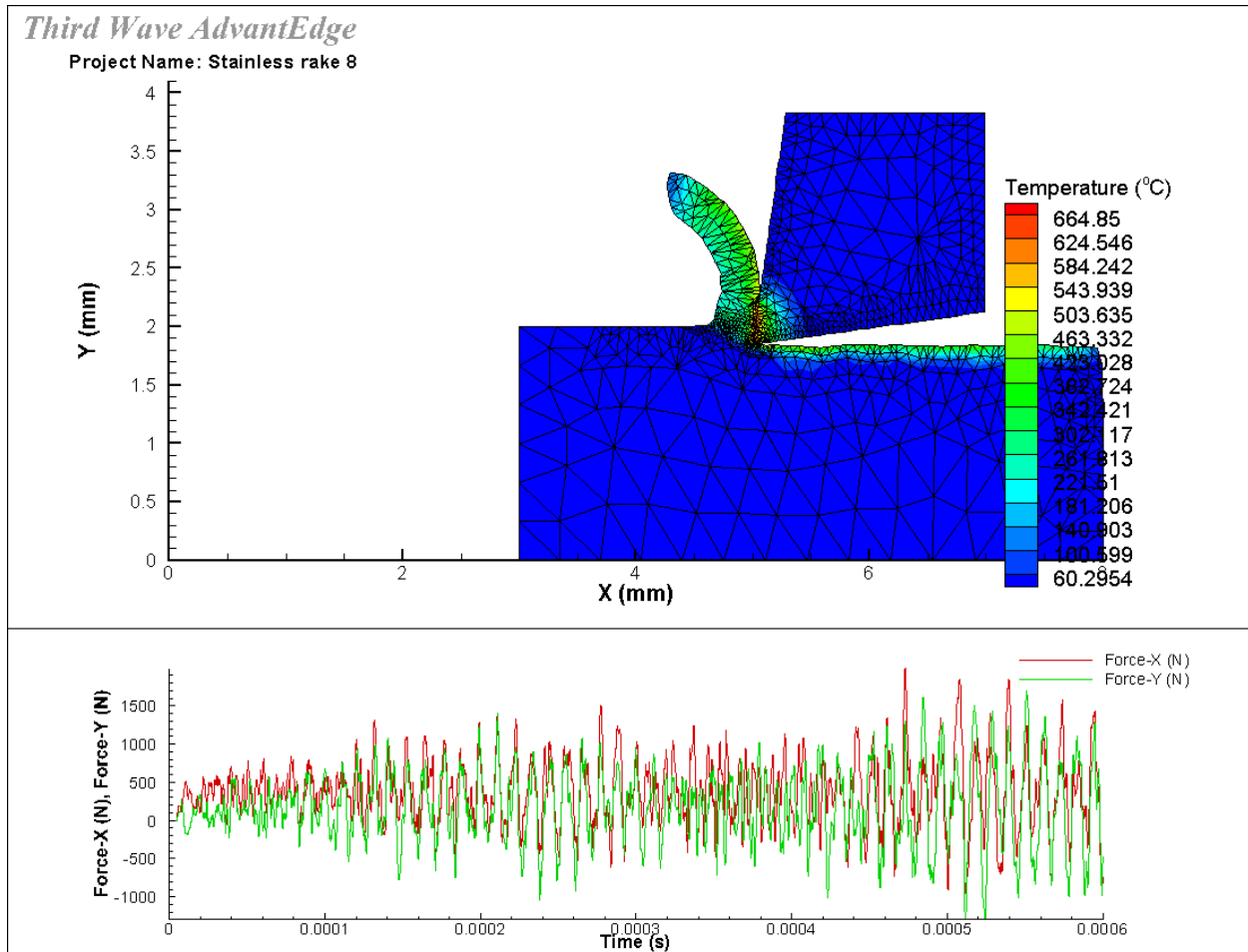

-- PROJECT --

Version = 7.1002
Project / Job Name = Stainless rake 8
Project / Job Description =
Units = SI
Process Type = turning
Workpiece Type = STANDARD
Tool Type = STANDARD
Tool Material Type = STANDARD

-- STANDARD WORKPIECE --

Workpiece length = 5.0 mm
Workpiece height = 2.0 mm
Material = 304L

-- STANDARD TOOL --

Tool File = Stainless rake 8.twt
Tool Process Type = OBLIQUE
Rake angle = 8.0 deg
Rake length = 2.0 mm
Relief angle = 8.0 deg
Relief length = 2.0 mm
Cutting Edge Radius = 0.02 mm
Tool Material = Carbide-General
Minimum Tool Element Size = 0.02 mm
Maximum Tool Element Size = 0.1 mm
Mesh Grading = 0.4
Coating Layer No. = 0

-- PROCESS --

Feed = 0.15 mm
Cutting speed = 300.0 m/min
Depth of cut = 1.0 mm
Length of cut = 3.0 mm
Initial temperature = 20.0 degC
Friction coefficient = Default
Cutting mode = General
External Coolant = OFF
Internal Primary Coolant = OFF
Internal Secondary Coolant = OFF

-- SIMULATION --

Simulation Mode = Demonstration
Steady state analysis = 0
Avg. Length of Cut Ratio = 10.0
Chip breakage = 0
Max. number of nodes = 24000
Max Element Size = 0.1 mm
Min Element Size = 0.02 mm
Fraction of Radius = 0.6
Fraction of Feed = 0.1
Mesh Refine = 2
Mesh Coarse = 6
Output Frame = 30

Rake angle-9⁰

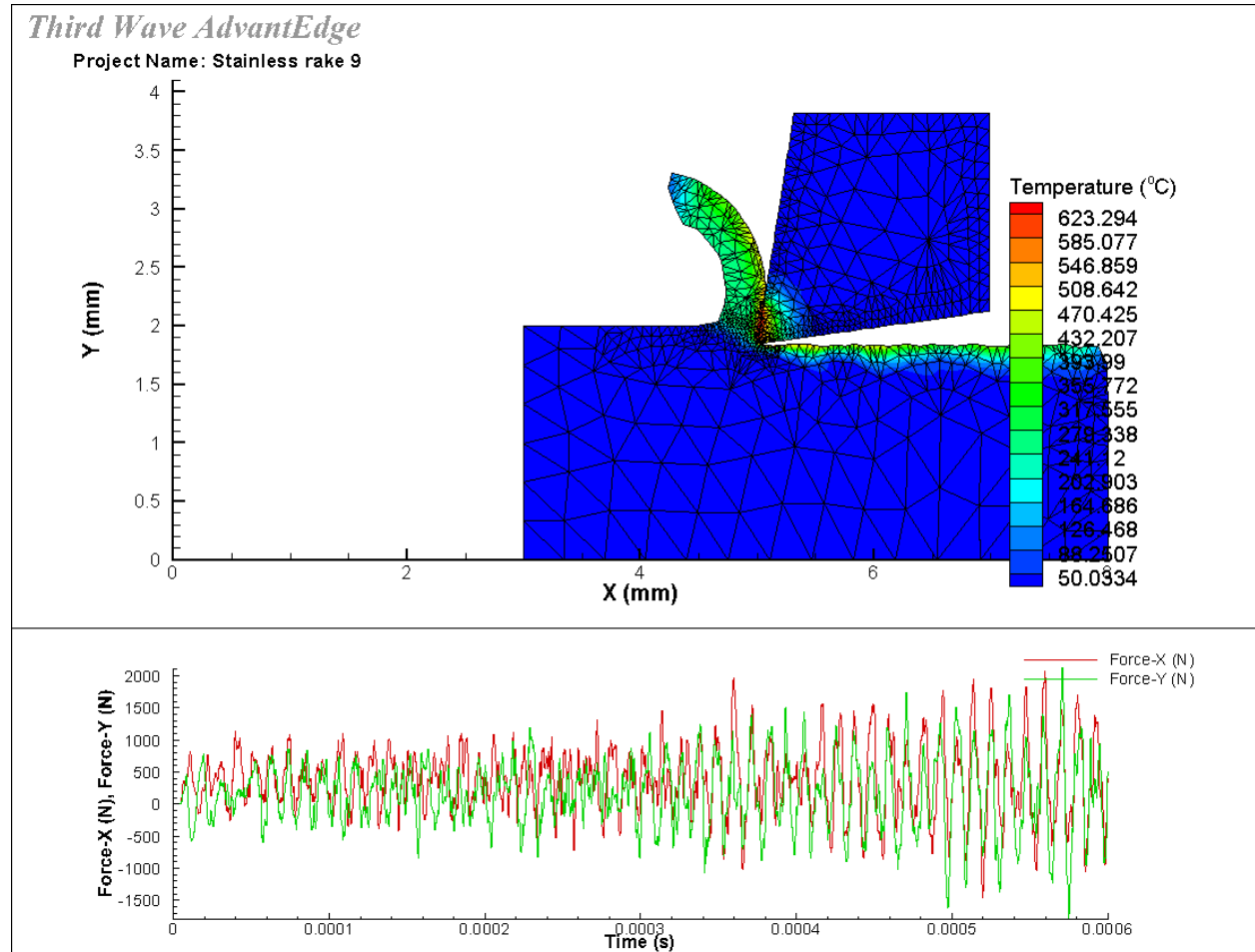

-- PROJECT --

Version = 7.1002
 Project / Job Name = Stainless rake 9
 Project / Job Description =
 Units = SI
 Process Type = turning
 Workpiece Type = STANDARD
 Tool Type = STANDARD
 Tool Material Type = STANDARD

-- STANDARD WORKPIECE --

Workpiece length = 5.0 mm
 Workpiece height = 2.0 mm
 Material = 304L

-- STANDARD TOOL --

Tool File = Stainless rake 9.twt
 Tool Process Type = OBLIQUE
 Rake angle = 9.0 deg
 Rake length = 2.0 mm
 Relief angle = 8.0 deg
 Relief length = 2.0 mm
 Cutting Edge Radius = 0.02 mm
 Tool Material = Carbide-General
 Minimum Tool Element Size = 0.02 mm
 Maximum Tool Element Size = 0.1 mm
 Mesh Grading = 0.4
 Coating Layer No. = 0

-- PROCESS --

Feed = 0.15 mm
 Cutting speed = 300.0 m/min
 Depth of cut = 1.0 mm
 Length of cut = 3.0 mm
 Initial temperature = 20.0 degC
 Friction coefficient = Default
 Cutting mode = General
 External Coolant = OFF
 Internal Primary Coolant = OFF
 Internal Secondary Coolant = OFF

-- SIMULATION --

Simulation Mode = Demonstration
 Steady state analysis = 0
 Avg. Length of Cut Ratio = 10.0
 Chip breakage = 0
 Max. number of nodes = 24000
 Max Element Size = 0.1 mm
 Min Element Size = 0.02 mm
 Fraction of Radius = 0.6
 Fraction of Feed = 0.1
 Mesh Refine = 2
 Mesh Coarse = 6
 Output Frame = 30

Rake angle-10⁰

Third Wave AdvantEdge

Project Name: Stainless rake 10

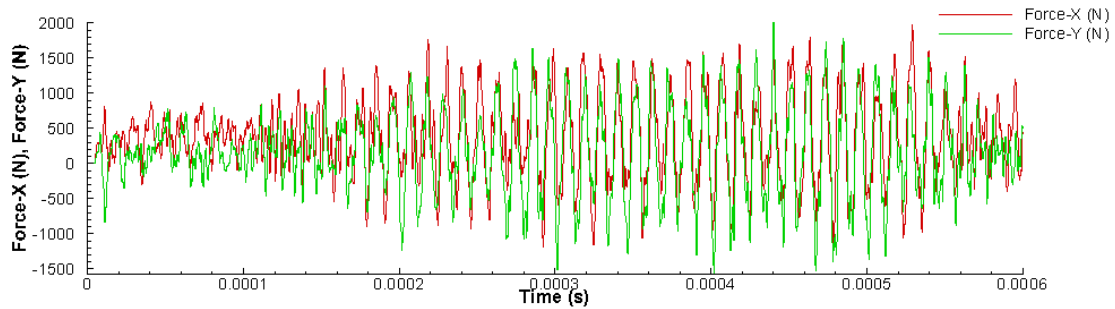
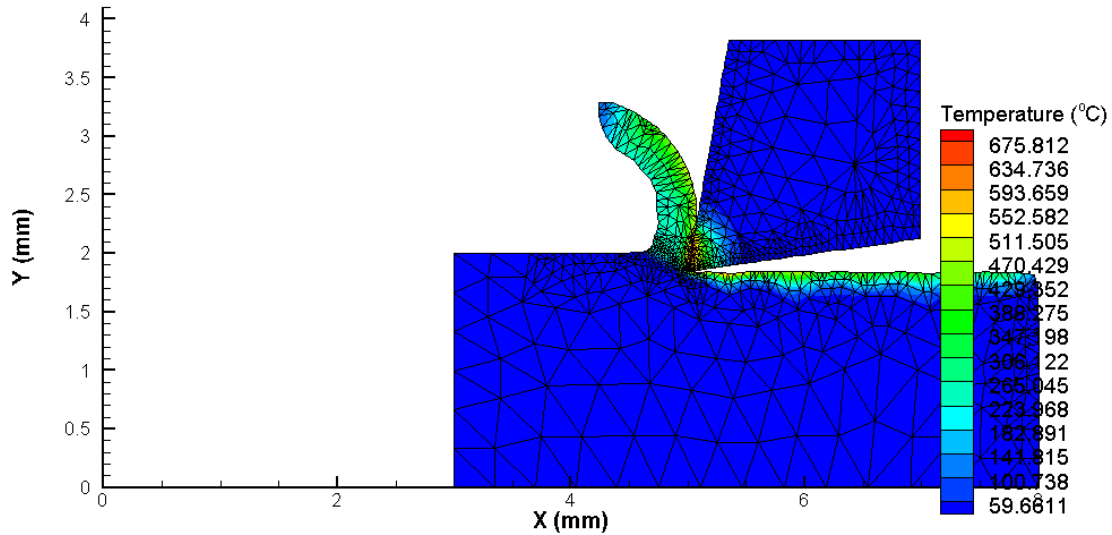

-- PROJECT --

Version = 7.1002
 Project / Job Name = Stainless rake 10
 Project / Job Description =
 Units = SI
 Process Type = turning
 Workpiece Type = STANDARD
 Tool Type = STANDARD
 Tool Material Type = STANDARD

-- STANDARD WORKPIECE --

Workpiece length = 5.0 mm
 Workpiece height = 2.0 mm
 Material = 304L

-- STANDARD TOOL --

Tool File = Stainless rake 10.twt
 Tool Process Type = OBLIQUE
 Rake angle = 10.0 deg
 Rake length = 2.0 mm
 Relief angle = 8.0 deg
 Relief length = 2.0 mm
 Cutting Edge Radius = 0.02 mm
 Tool Material = Carbide-General
 Minimum Tool Element Size = 0.02 mm
 Maximum Tool Element Size = 0.1 mm
 Mesh Grading = 0.4
 Coating Layer No. = 0

-- PROCESS --

Feed = 0.15 mm
 Cutting speed = 300.0 m/min
 Depth of cut = 1.0 mm
 Length of cut = 3.0 mm
 Initial temperature = 20.0 degC
 Friction coefficient = Default
 Cutting mode = General
 External Coolant = OFF
 Internal Primary Coolant = OFF
 Internal Secondary Coolant = OFF

-- SIMULATION --

Simulation Mode = Demonstration
 Steady state analysis = 0
 Avg. Length of Cut Ratio = 10.0
 Chip breakage = 0
 Max. number of nodes = 24000
 Max Element Size = 0.1 mm
 Min Element Size = 0.02 mm
 Fraction of Radius = 0.6
 Fraction of Feed = 0.1
 Mesh Refine = 2
 Mesh Coarse = 6
 Output Frame = 30