

EGR cooler design

Department of Mechanical and Chemical Engineering

Islamic University of Technology (IUT)



Osman Abdilahi ,Saqib Ali ,Muhammad waseem ,Mohammad kazem kaihan

Student ID: 141468 ,151459,151460,151461

Abstract

During the EGR cooler performance is a key issue that affects the function of EGR system as an anti-pollutant device. There is a significant concern to guarantee function of these devices during useful life of vehicle. Decrease of thermal efficiency and increase of gas pressure drop caused by soot deposition implies higher EGR gas temperature and lower EGR gas flow. Diesel engines are important power train solution for heavy duty vehicles and diesel power plants. Hence in this study theoretical analysis and CFD simulation of EGR cooler is carried out for improved emission and high heat recovery from engine exhaust. Use of the Cooled Exhaust Gas Recirculation (EGR) system is one of the most effective techniques currently available for reducing NO_x and PM emissions. It was observed that there is good agreement between experimental results and prediction from the development model. An important goal in diesel engine research is the development of a means to reduce the emissions of nitrogen oxides (NO_x). The use of a cooled exhaust gas recirculation (EGR) system is one of the most effective techniques currently available for reducing nitrogen oxides. Since PM (Particulate Matter) fouling reduces the efficiency of an EGR cooler, a tradeoff exists between the amount of NO_x and PM emissions, especially at high engine loads. In the present study, we performed engine dynamometer experiments and numerical analyses to investigate how the internal shape of an EGR cooler affects the heat exchanger efficiency. Heat exchanger efficiencies were examined for corrugated EGR coolers. The temperature and pressure distributions inside these EGR coolers were obtained in three dimensions using the numerical package program ANSYS.

Nomenclature

Symbol	Description
<i>EGR</i>	exhaust gas re-circulation
<i>m</i>	mass flow rate of fluid (<i>kg/second</i>)
C_p	specific heat of fluid ($J/kg - C^0$)
<i>LMTD</i>	Logarithmic Mean Temperature Difference(C^0)
<i>U</i>	overall heat transfer coefficient (w/c^0)
<i>Q</i>	amount of heat transfer taking place (watts)
<i>A</i>	area of heat ex-changer(m^2)
<i>ID</i>	inner diameter (<i>mm</i>)
<i>OD</i>	outer diameter (<i>mm</i>)
<i>l</i>	length of the heat ex-changer (<i>mm</i>)
<i>n</i>	number of tubes
D_t	diameter of tubes (<i>mm</i>)
D_s	diameter of shell (<i>mm</i>)
L_t	length of the tubes(<i>mm</i>)
t_s	thickness of shell (<i>mm</i>)
<i>D</i>	discharge(m^3/sec)
GHG	green house gases
NTU	Net Transfer unit
<i>U</i>	heat transfer coefficient
ε	<i>effectiveness</i>

Contents

1	Introduction	4
1.1	What is an EGR cooler and why do i need one?	6
1.2	How does an EGR system work?	6
1.3	The function of an EGR cooler	7
1.4	Problem Statement	7
2	Development of EGR-Cooler	9
2.1	Scope of study	10
2.2	purpose	12
3	Implementation of EGR in automobiles	14
3.1	The Diesel Engine	14
3.2	Emission formation in Diesel Combustion	16
3.3	Nitrogen Oxides (NO_X)	16
3.4	Particulate Matter	18
4	Experimental Setup	20
4.1	Designing and Fabrication	20
4.2	Experimental procedure	25
5	Numerical Analysis	28
5.1	Mathematical Modeling	30
5.2	Numerical Result	31
6	Experimental analysis	32
6.1	Determinations of parameters	33
6.2	determination of unknown parameters	35
6.3	Graphical representation of result	36

Chapter 1

Introduction

To augment the automotive engine performance EGR coolers are installed which are named as heat exchanger. Exhaust gases coming from the exhaust pipe of the vehicle are forced to circulate in EGR cooler while transferring its heat to the fluid flowing in EGR. The implementation of EGR reduces the amount of NO_x and impart significant impact in controlling the air pollution. Which is the main and sole reason of this experimental and numerical investigation. For decades, numerous researchers have been investigating thermal and pressure drop performance of EGR coolers by performing both experimental and numerical investigations. The numerical study in ref [1] investigated the overall performance of EGR cooler while considering the various crucial factors such as optimum temperature of exhaust gases, efficiency growth, weight reduction, dimension and expenditures reduction, and sediment reduction. In ref [2] engine dynamo-meter experiments were conducted to demonstrate the efficiency of shell and tube and stack type EGR coolers. It was witnessed that due to the greater surface area stack type EGR coolers tends to yield higher thermal performance and heat transfer rate as compared to the shell and tube type EGR coolers. Similar experimental study was performed in ref [3] to demonstrate the efficiency of two different type EGR coolers such as shell and tube type and stack type. Results demonstrated 20-25 percent higher heat transfer performance for stack type EGR cooler as compared to the shell and tube type EGR cooler. This performance enhancement was accompanied by a phenomenon of higher flow mixing of gas and surface area of stack type EGR cooler. Both experimental and numerical investigation was performed to demonstrate the effectiveness of

EGR cooler by investigating the internal shape of EGR cooler [4]. EGR coolers with plain and spiral type internal shapes were considered. Results were visualized in the form of temperature and velocity contours. It was concluded that EGR the implementation of modified internal shape EGR cooler yielded noteworthy augmentation in effectiveness as compared to the plain type EGR. However, both type of EGR coolers demonstrated poor performance under the fouling contemplation. It was conferred that the enhancement in efficiency of spiral type EGR cooler was the result of better mixing of gas flow and higher surface area. Moreover, the inclusion of particles in exhaust gas tends to have severe influence on EGR cooler performance and overall efficiency. Which has coerced various researchers to investigate the influence of particulate deposition on thermal and pressure drop performance of EGR coolers by performing various experimental and numerical investigations. In ref [5] an experimental study was investigated to demonstrate the influence of particulate fouling on thermal performance of EGR cooler. The impact of different gas flow velocities (30, 70 and 120m/s) on heat transfer performance of EGR cooler was extensively acknowledged. The results demonstrated that higher flow velocity tends to deteriorate the fouling layer and enhances the heat transfer performance. Similar experimental study was investigated in ref [6] to acknowledge the influence of asymptotic behavior of fouling formation on thermal performance of EGR cooler. It was concluded that the development of fouling layer induces significantly higher thermal resistance and the decrement in tubes cross-sectional area yielded higher gas flow velocity and hence fouling removal rate. The comprehensive experimental investigation in ref [7] elucidate the impact of fouling on thermal performance of modified EGR coolers. EGR cooler was encompassed of wavy fin type exhaust gas recirculation cooler which possessed four cases of two wave pitch and three fin pitch lengths. It was concluded that EGR with fin pitch of 3.6mm and wave pitch of 8.8mm tends to yield greater performance.

1.1 What is an EGR cooler and why do i need one?

An exhaust gas recirculation cooler, also known as an EGR Cooler is used to reduce the emissions that are caused by gas engines. This decrease in emissions will help your truck meet current emissions standards. In addition, if your EGR is working correctly it can also increase your engine's efficiency at the same time. It's the best of both worlds. Increased efficiency is created several ways. First, you may see a reduction in throttling losses as your throttle plate will be opened more than normal which then leads to an increase in manifold pressure. Next, your peak combustion temperatures will be lowered which in turn will reduce your heat rejection. Finally, you will find that your chemical dissociation and specific heat ratio are also reduced. All of these reductions lead to a more efficient engine, and are all obtained by utilizing an exhaust gas recirculation cooler. Most importantly, what this means for you, is an efficient engine that will save you money at the gas pump.

1.2 How does an EGR system work?

Exhaust Gas Re-circulation Coolers (EGR coolers) are devices that aid in reducing nitrogen oxide emissions (NOx) for internal combustion engines. Recirculating nitrogen oxide emission can substantially aid in the reduction of heat and pressure in the engine. In total it provides an excellent reduction in emissions, and most modern engines must use a system of re-circulation to meet current emissions standards set by the US Environmental Protection Agency. The general process is very simple. Exhaust Gas Re-circulation systems typically operate by taking some of the exhaust gas coming from recent combustion in the engine, passing it through filters to remove soot/particles, and then passing the gas back into the combustion cycle. The amount of gas can vary by EGR system, and in some more complex systems the amount of gas is varied based on engine load. In all methods the gas coming from the exhaust is always set to mix with some air before being passed back into the combustion chamber to ensure a solid fire. In diesel engines EGR cooling systems operate in the same method, they take lower oxygen exhaust and funnel it back into the intake of the engine. This actually sacrifices power and economy for better quality emissions and reduced engine temperature.

Diesel engines use particulate filters designed specifically to remove soot, ash, and other debris from the exhaust of the engine, and in advanced implementations of EGR coolers these filters remove these particles before passing the exhaust gas back into the combustion. In less advanced systems without filters this is known to cause some buildup of extra matter inside the areas of the engine where the gas is routed. Over time this can cause different problems in an engine like misfires, hesitation, and surging. Although the process does cause a loss of power in the engine, modern methods of EGR cooling are able to mitigate this loss substantially resulting in both better emissions quality for only a minor tax on efficiency and power of the engine.

1.3 The function of an EGR cooler

In many countries around the world, the emissions of NO_x from diesel and gasoline passenger cars and light commercial vehicles are restricted by legislation. Exhaust gas recirculation (EGR) is an effective technical solution to control NO_x values. The principle of EGR is that a controllable proportion of the exhaust gas is recirculated back into the engine. An EGR cooler is an emission related device that meets the new EURO 6 standards. Its purpose is to cool down the exhaust gas before they are returned into the engine to reduce NO_x values further more.

1.4 Problem Statement

Until the introduction of the EPA 2004 emission standards, the manufacturers of truck diesel engine had successfully avoided using exhaust gas recirculation (EGR) system. However, things changed and from 2007 onward, all diesel engine OEMs used some form of EGR though they did not call it EGR because EGR concerns emissions control. The emissions until today pollute the environment and contribute to global warming, acid rain, smog, odors and respiratory and other health problem. Diesel engine is a major source for air pollution. It's contains oxides of nitrogen (NO_x) carbon monoxide (CO), hydrocarbon (HC), carbon dioxide (CO₂), oxygen (O₂) and particulate matter (PM). High combustion temperatures produce nitrogen oxide (NO_x), a constituent of ozone. There are two ways to reduce peak combustion temperatures: Spark control system and Exhaust Gas Re-circulation EGR

systems (Mike and Hynes 2005). From the two ways, EGR system is found to be a better way to control NOx. EGR systems reduce peak combustion temperatures by diluting the incoming air/fuel mixture with small amount of “inert” (won’t undergo a chemical reaction) exhaust gas. Six to 14 percent concentration of exhaust gas, routed from the exhaust system to the intake manifold, mixed with the air/fuel mixture entering each cylinder, and reduced the mixture’s ability to produce heat during combustion (Mike and Hynes 2005).

Chapter 2

Development of EGR-Cooler

The Exhaust gas recirculation system is designed to reduce the amount of nitrogen oxides (NO_x). This NO_x is created by the engine during operating periods due to high temperature of combustion. When the combustion temperature exceeds 2500oF, a highly concentrated NO_x is formed. The EGR system works by recirculating a small amount of exhaust gas back to the combustion chamber through the intake manifold where it mixes with the incoming air/fuel charge. The high temperature and the pressure are reduced by diluting the air/fuel mixture under that condition.the The concept of exhaust gas re-circulation system is given by fig(2.1).

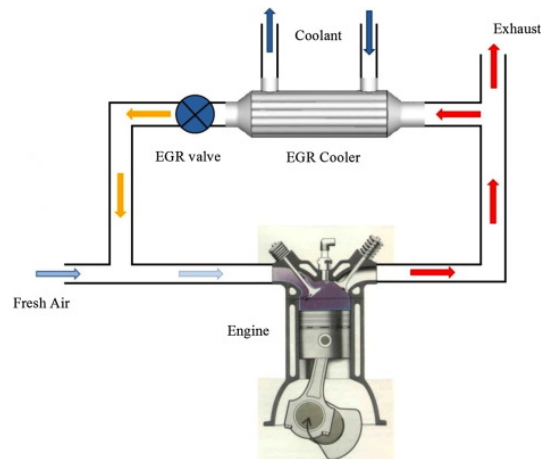

Figure 2.1: Concept of exhaust gas re-circulation system

The EGR flow has three operating conditions. The first condition is the high EGR flow; where it is necessary during cruising and mid-range acceleration. This is a condition where the combustion temperature is very high. Meanwhile the second condition is low EGR flow. Low EGR flow is needed during low speed and light load conditions. Finally the third condition is the no EGR flow condition. When the engine warms up and idle the wide open throttle, no EGR flow should occur during that condition. EGR operations could adversely affect engine operating efficiency or vehicle drivability. Exhaust gas re-circulation is used to re-circulate the exhaust gas back to the combustion chamber at intake manifold. In other words, to supply exhaust gas to the fresh mixture or to the air sucked into the cylinder. The use of exhaust gas re-circulation is needed to control the production of NO_x emission for gasoline and diesel engines (Richard 2006). The NO_x reduction is primarily caused by the following factors. 1. Heat capacity of the re-circulated exhaust gas is higher than the heat capacity of the air. This makes the low temperature increases for the same amount of energy release by combustion. 2.Reduction of the O₂ partial pressure and therefore, lower oxygen mass inside the cylinder, because a portion of the combustion air is replaced by exhaust gas with lower oxygen content. 3.reduction of the combustion speed and therefore lower temperature increase. When the combustion temperatures are too high it form a nitrogen oxides(NO_x). Any measure to decrease NO_x and emission lead to reduced the combustion temperature. The use of EGR will increased the soot and other solid particulate loading of lubricant oil. Re-introduction of the acidic exhaust gas product (sulfuric acid) into the engine will rapidly increase the total acid number (TAN) of the lubricant.Using high exhaust gas re-circulation (EGR) rates by increased boost pressure to avoid the negative impact on soot emissions is the one efficient method to control NO_x in order to achieve future emissions limits.

2.1 Scope of study

The reason to conduct this study was to improve engine performance through different innovative ideas to adopt for the future performance improvement of EGR coolers. That could help the researchers to get benefit in improving EGR cooler efficiency in different respective fields like automotive industry and diesel power plants to reduce NO_x and decrease

engine combustion temperature. Scope of this experiment is given by following sequence

- 1.Design of the new techniques of EGR system.
- 2.Fabricate the EGR system.
- 3.Conduct experimental work.
- 4.Get the data analysis.

FLOW CHART

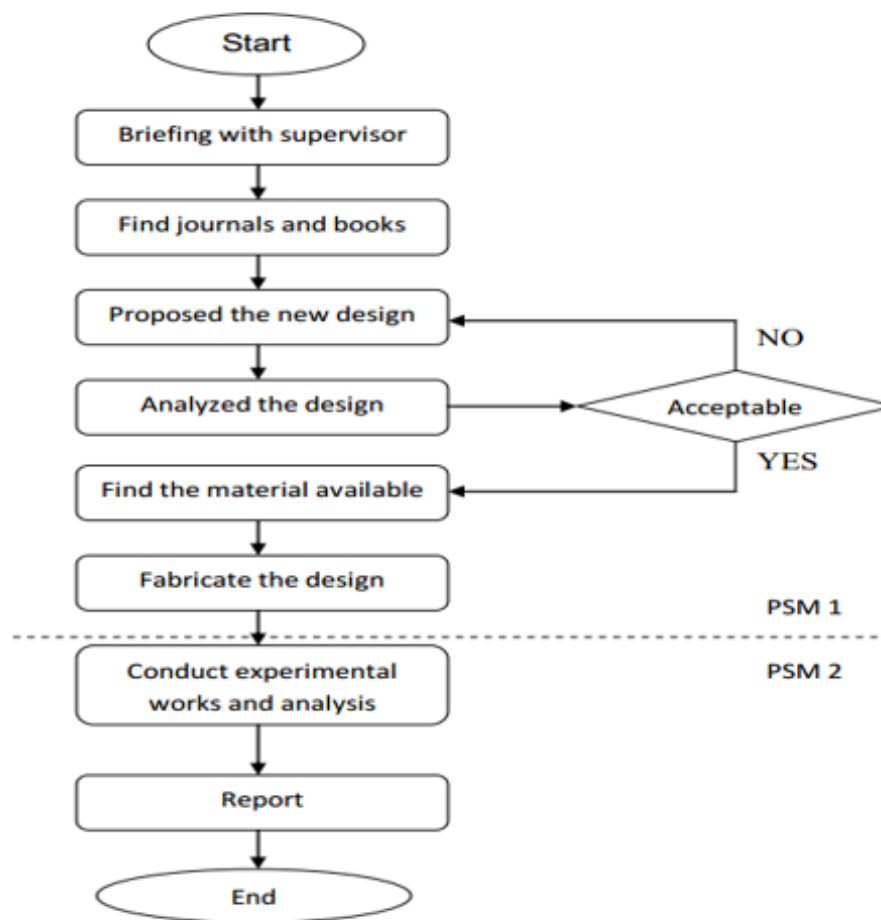

2.2 purpose

The concern about the environment and the influence of humans on it is growing throughout the world. In 1994 the United Nations framework convention on climate change entered into force. It states that the emissions of greenhouse gases (GHG) need to be limited to an amount that prevents dangerous human interference with the climate system [1]. Since then, more and more scientific evidence has been published that proves human influence on the climate. The transport sector is one of the major sources of GHG in Europe, with the road transport standing for almost 18 percent of the total emissions, see Figure (2.2) It is therefore of high importance to reduce these emissions.

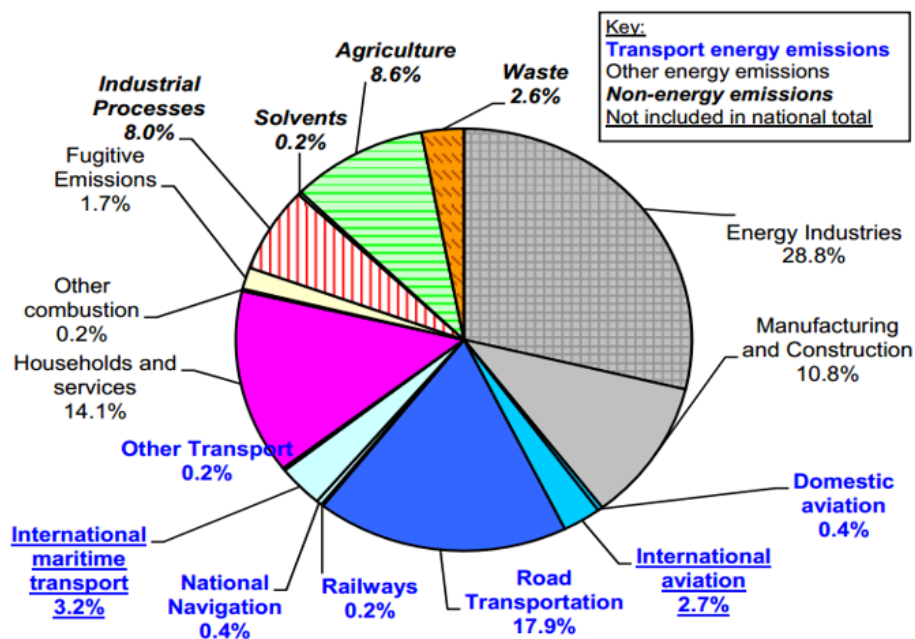

Figure 2.2: Total emissions of energy

Another part of the engine emissions are toxic gases that cause health problems to humans and damage the environment. To decrease these emissions, a number of laws have been implemented throughout the world, limiting the amount of these emissions that a vehicle may emit. Figure (2.3) shows the development of the emission legislation in Europe for heavy duty diesel engines.

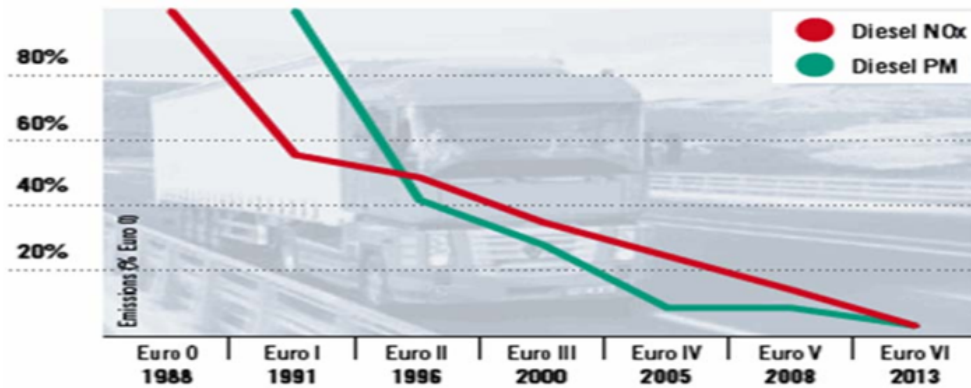

Figure 2.3: Emission legislation for heavy duty diesel engine

One of the harmful emissions of diesel engines are nitrous oxides NO_X , that can cause health problems and smog. A common way to reduce NO_X emissions in internal combustion engines is the use of exhaust gas recirculation (EGR). However, the extensive use of EGR may counteract the goal of reduced fuel consumption and therewith reduced GHG emissions. This work aims at increasing the understanding how EGR can be used in the most effective way, to reduce both NO_X emissions and fuel consumption penalty.

Chapter 3

Implementation of EGR in automobiles

The purpose of EGR system is to precisely regulate EGR flow under different operating condition. EGR system also has to override flow under conditions which would compromise good engine performance. Like the engine load change, the precise amount of exhaust gas which must be metered into the intake manifold varies significantly. This results in the EGR system operating on a very fine line between good NO_x control and good engine performance. The engine performance will be suffered if too much exhaust gas is metered. The engine may knock and will not meet strict emissions standards if too little EGR flows. The EGR ratio is referred as the theoretical volume of recirculated exhaust gas. The EGR ratio increases as engine load increases. Source: Toyota Motor sales.

3.1 The Diesel Engine

In a diesel engine, the chemically bound fuel energy is converted to heat through combustion. The heat leads to a pressure increase in the combustion chamber and from this high pressure gas, work is extracted by a moving piston. For land vehicles, 4-stroke engines are the most common engine variant. Here, the engine cycle is divided into four strokes. In the first stroke, the intake valves are open and air enters the combustion chamber while the cylinder volume is expanding through the piston motion. In the second stroke, the valves are closed and the piston compresses the air

inside the cylinder. When the piston is approaching top dead center, where the combustion chamber volume is the smallest, fuel is injected into the combustion chamber. The high pressure and temperature in the combustion chamber lead to self-ignition of the fuel and it burns during a short period. Figure(3.1) shows a photograph of the combustion in an optical access engine. The view is from the bottom of the cylinder through the piston that is made of glass in this engine. In the center, the injector is visible with the burning sprays, one for each injector hole. The black ring through the flames is due to an optical effect where the glass piston contains a piston bowl and is bent. With the valves still closed, the in-cylinder pressure increases rapidly and during the expansion stroke the piston moves downwards thus extracting mechanical work from the high-pressure gas. The longitudinal piston motion is converted into a rotational motion by the crankshaft. This stroke is also referred to as the work or power stroke, as it is here the useful work is extracted from the process. To come back to the starting point, the exhaust valves are opened during the last stroke and the exhaust gases are expelled from the combustion chamber by the piston that is moving upwards.

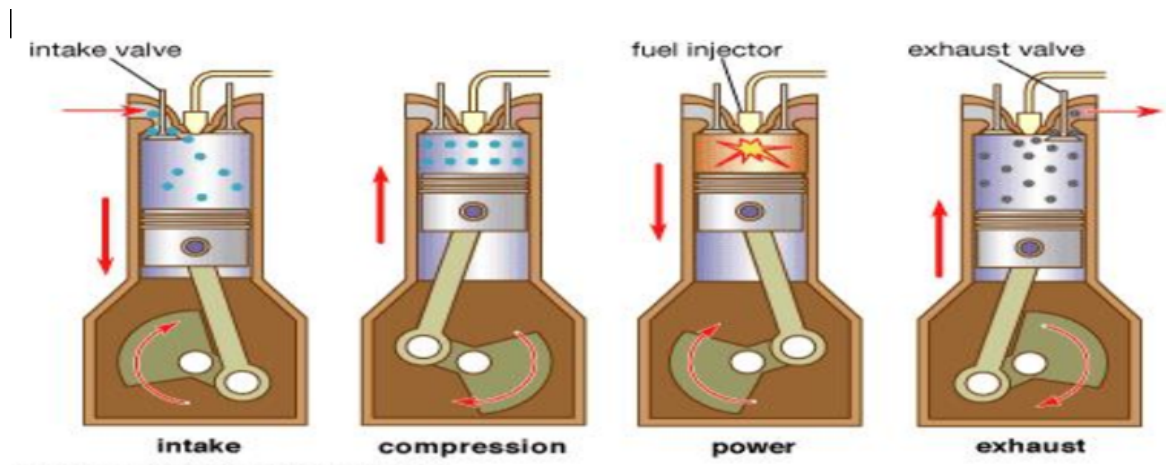

Figure 3.1: 4 stroke cycle

The amount of fuel that can be burned during one engine cycle is dependent on the amount of oxygen that is available in the combustion chamber. To increase the power output of an engine the fuel amount is increased, thus more air is needed for the combustion. To increase the air mass in the cylinder it is common to compress the air prior to entering the cylinder, thus increasing the air density. In most modern engines this is achieved by a turbocharger. A turbocharger consists of a compressor and a turbine that are coupled together by the turbocharger shaft. The turbine is driven by the hot exhaust gases from the engine and drives the compressor via the shaft. The compressor then raises the pressure of the intake air to increase its density. To augment the air density even further, a charge air cooler (CAC) that cools the air after the compressor and before entering the cylinders is standard in today's engines. The CAC also lowers the combustion temperature which helps to limit NOX formation.

3.2 Emission formation in Diesel Combustion

During Diesel combustion, several toxic and non-toxic gases are formed. The non-toxic parts are water and carbon dioxide. While water is unproblematic, the emission of CO₂ has negative impacts on the environment. CO₂ is believed to be the main cause of global warming and therefore, its emission has to be reduced. The formation of CO₂ is directly proportional to the fuel consumption of an engine, if hydrocarbon fuel is burned. This means that for a reduction of CO₂, the fuel consumption has to be reduced. The two most problematic emissions in diesel engines are nitrogen oxides and soot particles. HC and CO emissions are quite low and can be reduced further with the help of an oxidation catalyst.

3.3 Nitrogen Oxides (NO_X)

Nitrogen oxides, NO and NO₂, are referred to as NOX. They are harmful for the lungs when local concentrations get too high. They also contribute to acid rain and form smog in combination with hydrocarbons. [14] NOX formation takes place in combustion zones with high oxygen concentration and high combustion temperatures. The most important mechanism for

NOX formation in internal combustion engines are thermal NOX and prompt NOX. A theoretical approach to the thermal NO formation is the extended Zeldovich mechanism. It consists of three chemical reactions that form NO [15]:

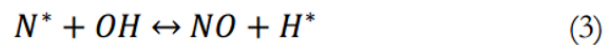
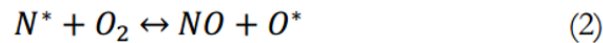
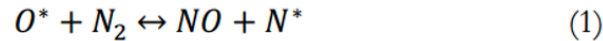

The triple-bond in the N₂ molecules makes a high kinetic energy necessary to activate these reactions. Therefore, the chemical rate is only high enough to form significant amounts of NOX if the temperatures are above 2200 K.

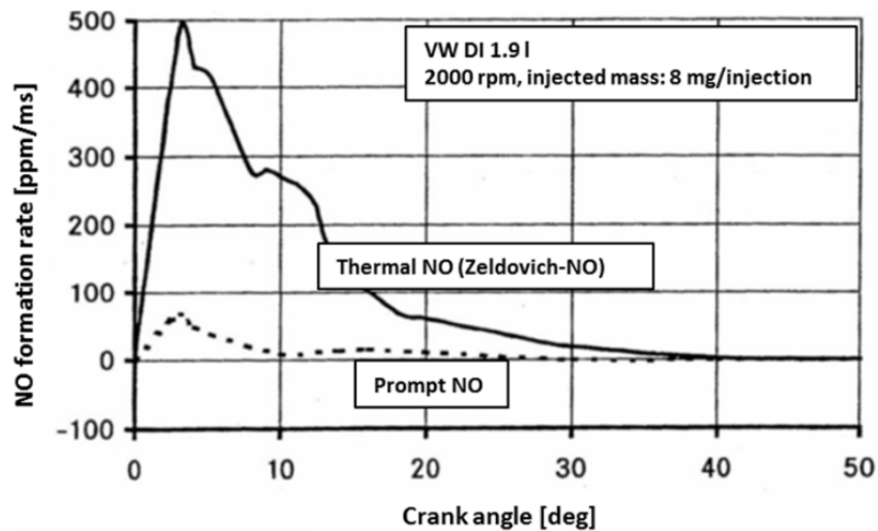
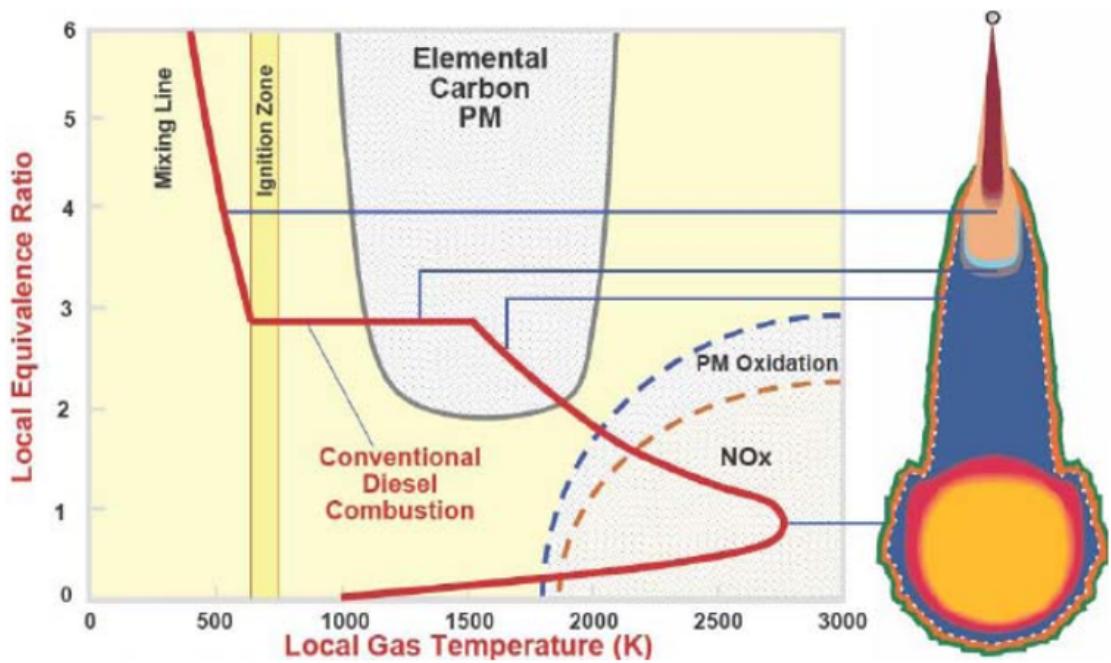

Figure 3.2: Simulation of NO_x formulation in a diesel engine

The prompt NOX, or Fenimore NOX, occurs in a process initiated by the rapid reaction of CH radicals with molecular nitrogen to build amines or cyano compounds, subsequent reactions then form the NO [13]. As Figure 5 shows, they are of minor importance in diesel combustion [12].

3.4 Particulate Matter

Particulate matter, mainly consisting of soot, is the other problematic emission from diesel engines. They are suspected to be carcinogenic [11]. In addition to that, they have been shown to increase respiratory symptoms and increase mortality in cardiovascular and respiratory diseases [13]. Figure(3.3) shows the combustion path of conventional diesel combustion in a ϕ -T-map. The equivalence ratio is defined as the ratio between the actual fuel-to-oxidizer mass ratio and the stoichiometric fuel-to-oxidizer ratio. Another common way to describe the air to fuel ratio is the use of λ , which is defined as the inverse of ϕ . It can be seen in Figure 6 that soot is formed in parts of the spray where the oxygen concentration is low. Later in the combustion, when the local temperature and oxygen concentration get higher, most of the formed soot is oxidized.



Soot formation is not entirely understood. A widely accepted explanation divides it into several steps, as Figure (3.4) illustrates. It starts with the formation of molecular precursors of soot, polycyclic aromatic hydrocarbons (PAH). These PAHs build up from benzene under addition of C₂, C₃ or other small units to PAH radicals. During the next steps, the nucleation of particles, the PAHs collide with each other and stick together to build clusters and evolve into solid particles. The mass of these particles is then increased via the addition of gas phase species such as PAH and acetylene. Coagulation occurs via particle-particle collisions which decreases the particle number while the particle size grows. The coagulation takes place shortly after the formation of particles while the agglomeration occurs in later stages of soot formation. Here, three dimensional structures are formed that stick together.

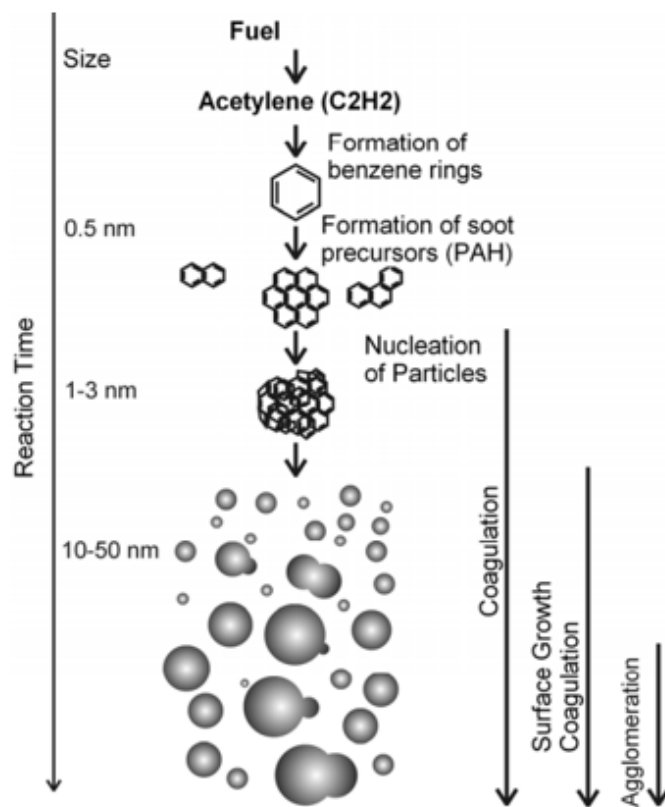

Figure 3.3: Caption

Chapter 4

Experimental Setup

4.1 Designing and Fabrication

Methods and materials used for manufacturing a geometry In the EGR cooler system, 20–30 percent of the hot combustion gases from the diesel engine is re-circulated into the EGR cooler, and significantly cooled down by the coolant in the EGR cooler. The inlet coolant and inlet exhaust gas temperatures in the EGR cooler are around 130–150C, respectively. As a result of heat exchange between the coolant and the exhaust gas, the outlet exhaust gas temperature is reduced to around 80–100 C. It is then mixed with fresh air before being injected into the engine cylinder. This process results in the reduction of combustion chamber temperature as well as NOX emission from the engine. In this study, corrugated type EGR cooler with different shape was experimentally tested to find out the best performing corrugated EGR cooler. The EGR coolers were thoroughly checked for leakage before brazing, and they all had excellent properties after brazing. EGR COOLER is a class of heat ex-changer. Heat exchanger is a device used to transfer heat between a solid and a fluid or between two or more fluids. we concerned with the study of EGR (shell-and- corrugated tube) cooler using segmental type baffles. Also the main components of shell and tube type heat cooler are shown in drawing and its detail discussion is given. Moreover the constructional details and design methods of shell and tube heat ex-changers are also given[31]. Also other research papers are studied and the review from those papers is also describes in this study with some of the review work in detail. The shape and arrangement

of baffles are of essential importance for the performance of heat ex-changers. The most commonly used baffle is the segmental baffle.

Basic components of EGR cooler

- 1.tubes (tube bundles)
- 2.tube sheets
3. shell
- 4.impingement plates
- 5.channels covers
6. baffles.

Corrugated Tubes

The tubes are the basic components of the EGR COOLER, providing the heat transfer surface between one fluid flowing inside the tube and the other fluid flowing across the outside of the tubes. It therefore recommended that the tubes material should be highly thermal conductive otherwise proper heat transfer will not occur. The tubes may be seamless or welded and most commonly made of steel alloy .The tubes we have used in our geometry are made of steel alloy. The external grooves on the tube are made by threading operation on lathe machine.

Shell

The shell is simply the container for the shell side fluid, and the nozzles are the inlet and exit ports. The shell normally has a circular cross section and made form a cylindrical pipe and is made of low carbon steel.

Baffles

Baffles serve two functions: Most importantly, they support the tubes in the proper position during assembly and operation and prevent vibration of the tubes caused by flow induced eddies, and secondly, they guide the shell side flow back and forth across the field, increasing the velocity and heat transfer coefficient. The baffles are designed in such a way that it will fix all the tubes accordingly fit in the shell

Tube layout

Tube layout applied in our geometry is equilateral triangle between tubes. Triangular pitch (300 layout) is better for heat transfer and surface area per unit length (greatest tube density). The triangular pitch: provides a more compact arrangement, usually resulting in smaller shell, and the strongest header sheet for a specified shell-side flow area. It is preferred when the operating pressure difference between the two fluids is large.

Nano Fluids

Any metal will have most enriched properties as a power in Nano (10^{-9}) size than in its solid form. Basically heat exchangers use water ethylene glycol etc. But here we are using Nano fluids for better rate of heat transfer. "Heat transfer in mini heat ex-changer using Nano fluids", Thus we are opting for nanoparticles of copper oxide and magnesium oxide with water thus making it a Nano fluid as a medium in heat ex-changer.

Pump

One pump is used in our experiment for supplying the fluid to the shell.

Thermocouples

These are used to measure the inlet and outlet temperatures of fluid in the shell and tube of EGR cooler.

Design and Fabrication of Components

Design and Fabrication of Components

*Design on solid works
machine shop*

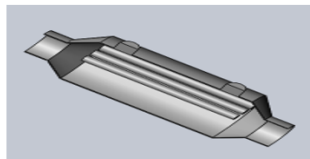

fabrication in IUT



SPIRAL TUBES

Design on solid works



Fabrication in IUT workshop



Dimensions of EGR cooler tubes

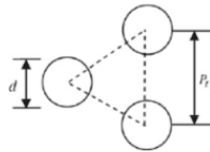

Segmental Baffle



Welding of spiral tubes and baffles



Fixing of tubes in shell

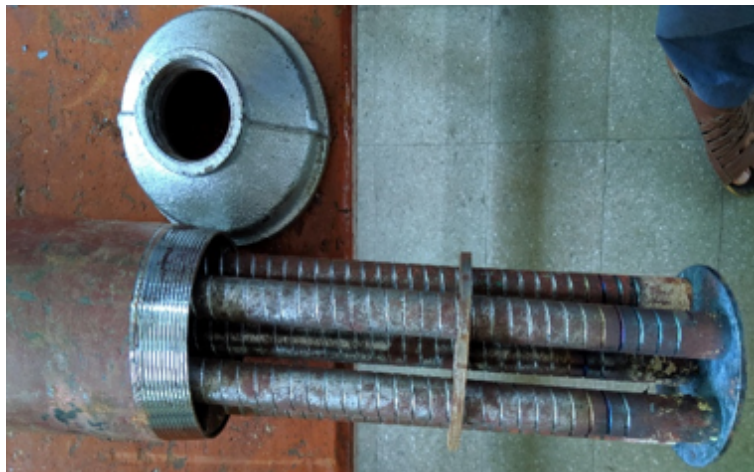

4.2 Experimental procedure

In this study, corrugated type EGR cooler was experimentally tested to find out the best performing corrugated EGR cooler. The EGR coolers were thoroughly checked for leakage before brazing, and they all had excellent properties after brazing. Four K-type (ChromegaAlumega) thermocouples of 0.26 mm diameter are used to measure the exhaust gas and coolant temperatures. All the thermocouples are calibrated against platinum resistance thermometer potential. The experiment is done on shell and corrugated tubes EGR cooler of Segmental Baffles under summer ambient conditions in the period August – September 2019 by following steps

1. The EGR cooler is connected to the water pump to supply cold water.
2. Connect the motor to 230V, 50Hz power supply.
3. Place the motors into the container.
4. The motor is pumping the water into shell with Segmental baffle.
5. As the hot exhaust gases and cold water flowing through shell and tubes, heat transfer takes place between hot and cold water by different modes like convection and conduction.
6. Measure the temperatures of the water at inlet and outlets of shell and also temperature of gases at the tube inlet and outlet of tubes and also note the time taken to fill 1 liter container
7. The experiment is repeated at different hot gases temperatures.

Experimental setup

The main objective of this study was to investigate the heat transfer parameters and fluid flow characteristics of corrugated built to supply the cooling fluid used in the EGR cooler. Therefore, two cycles were considered to investigate the EGR cooler. The first cycle is related to the water that is provided from the prepared setup. The second cycle is related to the engine exhaust gases supplied from engine outlet. The four-cylinder petrol engine used in this study and four K-type thermocouples (Chromega Alumega) with an 50 to 600 C temperature range were used to measure the temperature of the EGR and the cooling liquid. The temperature data of the thermocouple were recorded by a TM925-type thermometer. In order to determine the flow rate of the cooling liquid, a F016-p type flow meter was used. Various EGR ratios were measured at different engine rpms and constant operating speed of the engine.

Experimental setup diagram

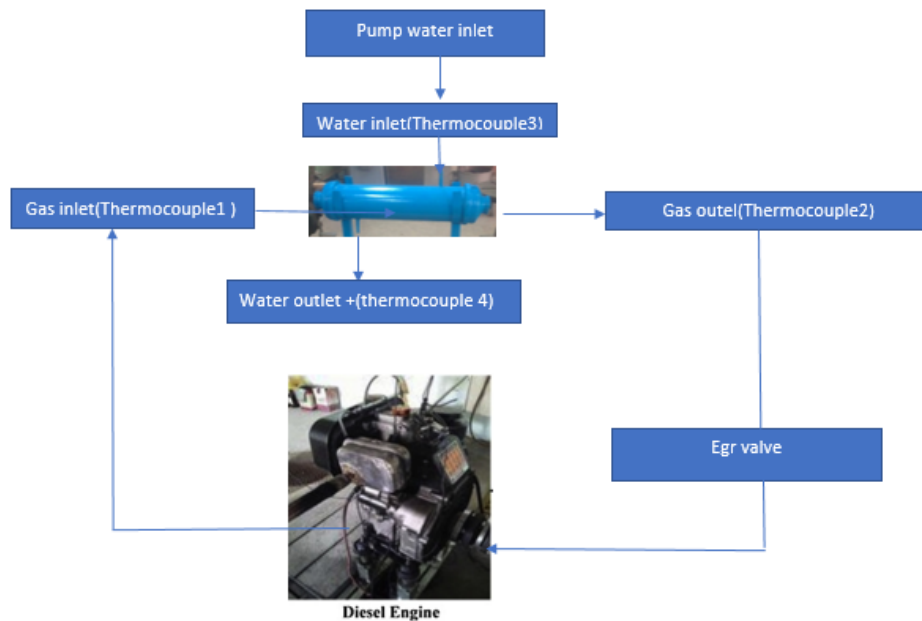

Some snaps of experiment

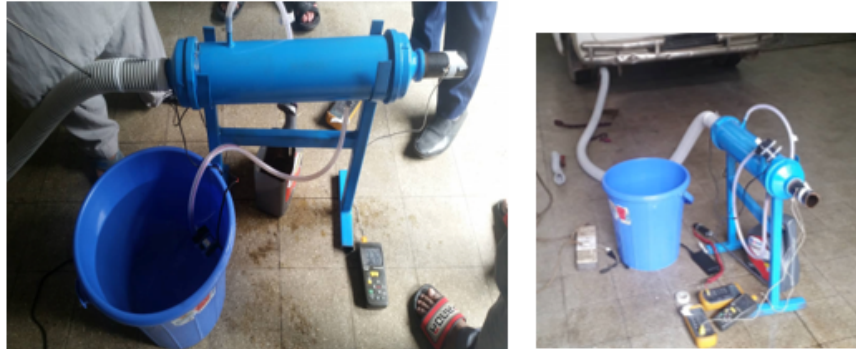

Memory during experiment



Chapter 5

Numerical Analysis

To acknowledge ourselves with commercial software ANSYS v14 we performed few simulations to avail the better understanding of fluid flow characteristics and experimental results.

Steps involved in this section are elucidated as follows

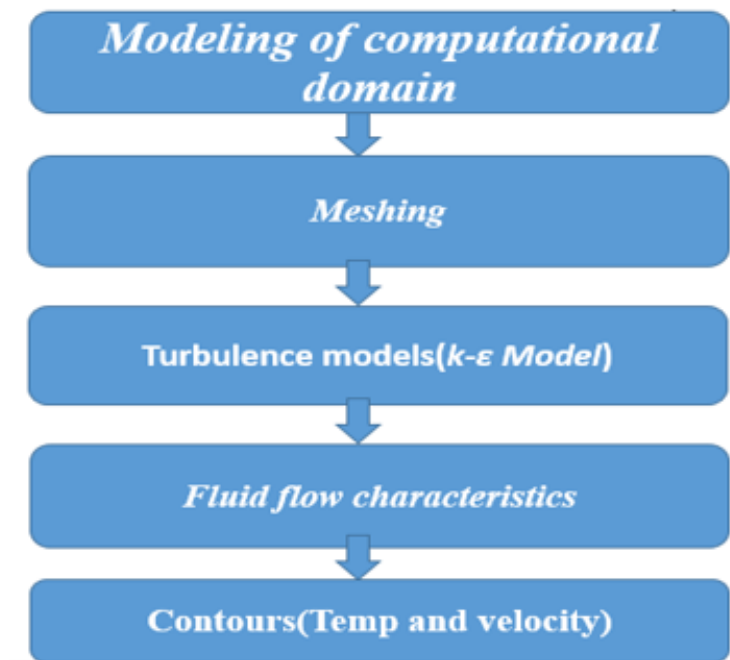

Geometric configuration

The very first step for numerical analysis is to design the geometry. For that purpose, we used SOLID WORKS software. we have drawn all the parts on solid works according to the given dimensions in the table above. Then the geometry was saved in parasolid binary file. After that the geometry was imported to ANSYS software to apply meshing and boundary layer conditions like temperature and velocity conditions to find out our desired temperature and pressure contours.

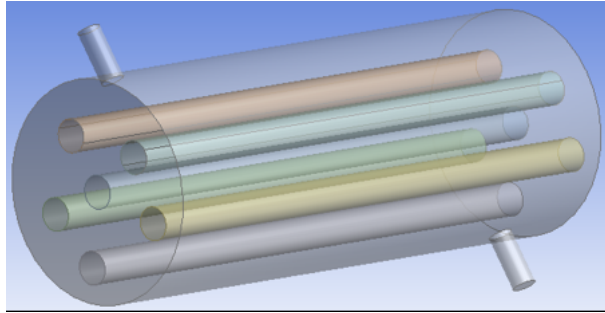

Mesh analysis

Meshing type was unstructured tetrahedron and then we used maximum number of elements to find out good results. The number of elements were elements and the nodes were 800000 and 15500 respectively.

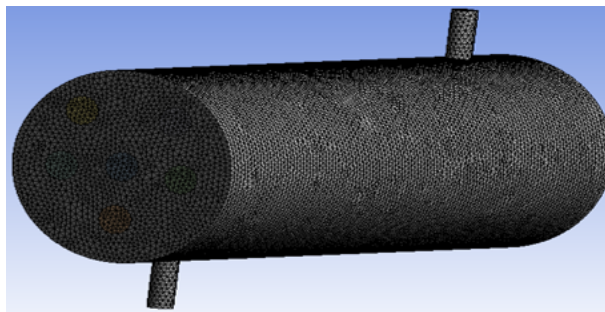

5.1 Mathematical Modeling

$k - \varepsilon$ Model

1. Relatively simple to implement.
2. Leads to stable calculations that converge relatively easily.
3. Reasonable predictions for many flows. **The momentum equation**

- x-component:

$$\bullet \quad \frac{\partial u}{\partial t} + \left(u \frac{\partial u}{\partial x} + v \frac{\partial u}{\partial y} + w \frac{\partial u}{\partial z} \right) = \frac{\partial p'}{\partial x} + \frac{1}{\text{Re}_H} \left(\frac{\partial^2 u}{\partial x^2} + \frac{\partial^2 u}{\partial y^2} + \frac{\partial^2 u}{\partial z^2} \right)$$

- y-component

$$\bullet \quad \frac{\partial v}{\partial t} + \left(u \frac{\partial v}{\partial x} + v \frac{\partial v}{\partial y} + w \frac{\partial v}{\partial z} \right) = \frac{\partial p'}{\partial y} + \frac{1}{\text{Re}_H} \left(\frac{\partial^2 v}{\partial x^2} + \frac{\partial^2 v}{\partial y^2} + \frac{\partial^2 v}{\partial z^2} \right)$$

- z-component:

$$\bullet \quad \frac{\partial w}{\partial t} + \left(u \frac{\partial w}{\partial x} + v \frac{\partial w}{\partial y} + w \frac{\partial w}{\partial z} \right) = \frac{\partial p'}{\partial z} + \frac{1}{\text{Re}_H} \left(\frac{\partial^2 w}{\partial x^2} + \frac{\partial^2 w}{\partial y^2} + \frac{\partial^2 w}{\partial z^2} \right)$$

- Where p' is the modified pressure given by:

$$\bullet \quad p' = p + \frac{2}{3} \rho.$$

$$\bullet \quad \mu_{\text{eff}} = \mu + \mu_t$$

$$\bullet \quad \rho \left[\frac{\partial k}{\partial t} + \left(u \frac{\partial k}{\partial x} + v \frac{\partial k}{\partial y} + w \frac{\partial k}{\partial z} \right) \right] - \frac{\mu_{\text{eff}}}{\sigma_k} \left(\frac{\partial^2 k}{\partial x^2} + \frac{\partial^2 k}{\partial y^2} + \frac{\partial^2 k}{\partial z^2} \right) = P_k - \rho \varepsilon$$

$$\rho \left[\frac{\partial \varepsilon}{\partial t} + \left(u \frac{\partial \varepsilon}{\partial x} + v \frac{\partial \varepsilon}{\partial y} + w \frac{\partial \varepsilon}{\partial z} \right) \right] - \frac{\mu_{\text{eff}}}{\sigma_\varepsilon} \left(\frac{\partial^2 \varepsilon}{\partial x^2} + \frac{\partial^2 \varepsilon}{\partial y^2} + \frac{\partial^2 \varepsilon}{\partial z^2} \right) = \frac{\varepsilon}{k} (C_{\varepsilon 1} P_k - C_{\varepsilon 2} \rho \varepsilon)$$

5.2 Numerical Result

Temperature

After applying temperature and velocity conditions. Effective results were found, as we can see in the given figures below. Water having temperature decreases the temperature over the tube surface resulting lowering the temperature of the air. Temperature of gases decreases at different distances

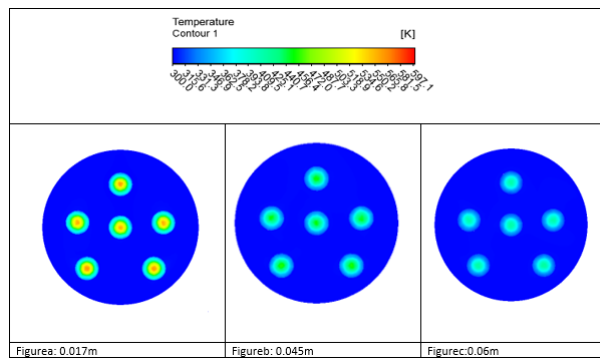

Velocity

Velocity of the fluids decreases due to the wall frictions and eddies. But shows effective results those can be compared with the experimental data.

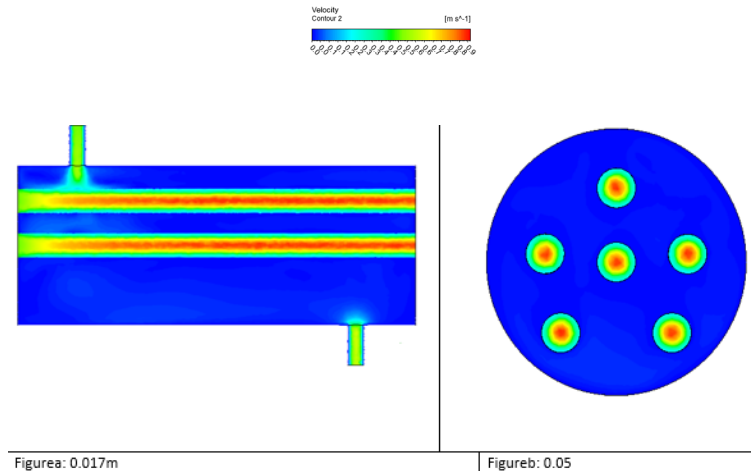

Chapter 6

Experimental analysis

In this experiment we have done experienced on counter flow shell and grove tube heat ex-changer,in which the transfer of heat heat takes place from hot exhaust gas to coolant water as shown in figure(5.1).here the coolant is water and the hot gas is exhaust gas form engine.

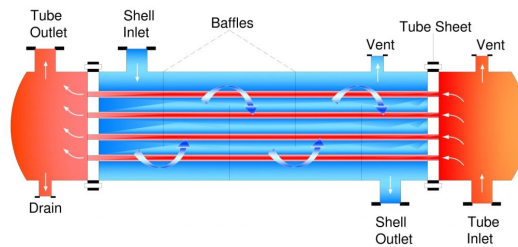

Figure 6.1: heat ex-changer

Assumptions

To satisfied the mass conservation of particles and energy conservation are required the following assumptions:

1. Coolant temperature is constant.
2. In diesel engine The density of exhaust gas is assumed to be $1.293kg/m^3$ at $273k^0$ and $101.325kpa$.
3. Gas properties vary as a function of mean temperature
- 4.Constant wall temperature (equals to coolant temperature).
- 5.Soot properties do not vary with the temperature and layer thickness.

Boundary conditions Inlet temperature of gas= $383k^0$
 Coolant temperature inlet= $305k^0$
 Density of exhaust gas= $1.293kg/m^3$
 Average velocity of exhaust gas= $5.5m/s$

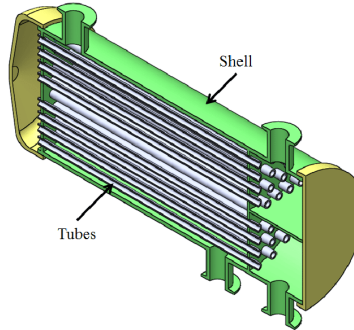

Figure 6.2: boundary conditions

after assigning the boundary conditions ,now we are going for the determination of different parameters. we are using the energy balance equations to find out the unknown parameters values:

6.1 Determinations of parameters

The amount of heat transfer for the system has given by equation(1)

$$Q = m_g c_{pg}(t_{g1} - t_{g2}) = m_w c_{pw}(t_{w1} - t_{w2}).....(1)$$

Then we consider the LMTD expression is given by equation (2)

$$LMTD = \frac{\nabla T_1 - \nabla T_2}{Ln(\nabla T_1 / \nabla T_2)}.....(2)$$

where $\nabla T_1 = (t_{g1} - t_{w2})$, $\nabla T_2 = (t_{g2} - t_{w1})$, g indicates exhaust gas and w stand for water.

where the total area for the heat transfer is given by equation (3)

$$A = \pi d_t l_t n \quad \dots\dots\dots(3)$$

where n is number of tubes,
 d_t is diameter of the tube,
 l_t is length of the tube
 A is area of the tubes

The mass flow rate of the exhaust gas is calculated by equation(4)

$$m_{tube} = \rho A V_g \quad \dots\dots(4)$$

where ρ is density of the exhaust gas, A area of heat transfer and V_g velocity of the exhaust gas.while, tacho-meter has used to measure the velocity of the exhaust gas. to measured the mass flow rate of coolant water in the shell can be calculated by discharge of coolant water form the shell,in which the discharge is given by equation (5)

$$D = V/t \quad \dots\dots\dots(5)$$

where D is discharge of coolant and t is the time taken to fill 2 litter bottle. then the mass flow rate of coolant water is given by equation (6)

$$m_{shell} = \rho D \quad \dots\dots(6)$$

The overall heat transfer coefficient is given by equation (7)

$$U = \frac{Q}{A * LMTD} \quad \dots\dots(7)$$

before going to calculate the NTU ,we need to find some more values which is given by the following equations let say equation (8) and (9)

$$C_{shell} = m_{shell} * C_p \quad \dots(8)$$

$$C_{tube} = m_{tube} * C_p \quad \dots(9)$$

now needed to calculate the NTU which is function of area, overall heat transfer coefficient and log mean temperature difference ,which is given by equation (10)

$$NTU = \frac{UA}{LMTD} \quad \dots\dots\dots(10)$$

The effectiveness for the counter flow heat-ex-changer in terms of NTU which has calculated by equation (11)

$$\varepsilon = \frac{NTU}{1+UTN} \quad \dots\dots\dots(11)$$

6.2 determination of unknown parameters

To find out the unknown parameters,needed to measure with different components which given in the following table.

observation data									
No OBS	time	Inlet temperature of water	outlet temperature of water	Inlet exhaust gas temperature	outlet exhaust gas temperature	velocity of the exhaust gas	volume flow rate of water	RPM	
1	17.6	300	305.8	381	380	4.37	0.002	1000-2000	
2	17.6	300	307.01	390	382.5	4.32	0.002	1000-2000	
3	17.6	300	309.5	400	384.3	4.92	0.002	1000-2000	
4	17.6	300	311.3	420	418.7	5.03	0.002	1000-2000	
5	17.6	300	313.5	440	420.5	5.01	0.002	1000-2000	
6	17.6	300	315.6	460	435.6	4.91	0.002	1000-2000	

Experimental Result														
no of	Dt1 (tg1-tw2)	dt2(tg2-tw1)	LMTD	discharge flow of water	mass flow rate of water	c shell	velocity of the exhaust gas	mass flow rate of exhaust g	c tube	c_max/c_min	Q	U	NTU	effectiveness
1	75.2	80	77.58	0.000113636	0.113636364	0.47579545	4.37	0.940793265	3.9391014	8.278980732	296.220425	22.9324781	8.0384	0.89
2	82.99	82.5	82.74	0.000113636	0.113636364	0.47579545	4.32	0.93002904	3.89403159	8.184255552	323.165682	23.458243	8.2227	0.89
3	90.5	84.3	87.36	0.000113636	0.113636364	0.47579545	4.92	1.05919974	4.43486931	9.320957712	401.355673	27.5932301	9.6722	0.9
4	108.7	118.7	113.63	0.000113636	0.113636364	0.47579545	5.03	1.082881035	4.53402289	9.529353108	492.848289	26.0498969	9.1312	0.9
5	126.5	120.5	123.48	0.000113636	0.113636364	0.47579545	5.01	1.078575345	4.51599497	9.491463036	571.273364	27.7864533	9.7399	0.91
6	144.4	135.6	139.95	0.000113636	0.113636364	0.47579545	4.91	1.057046895	4.42585535	9.302012676	639.093512	27.4269344	9.6139	0.9

6.3 Graphical representation of result

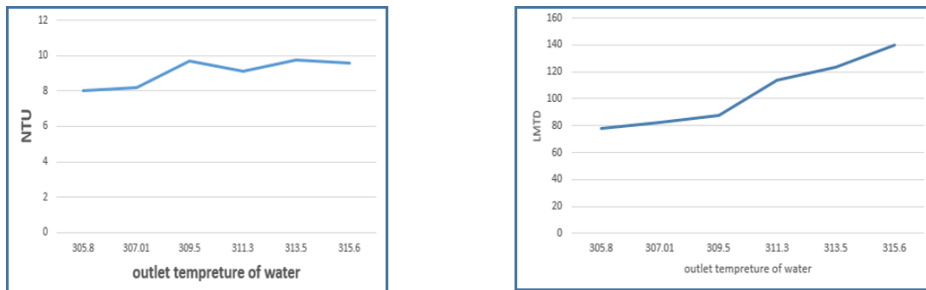

Figure 6.3: NTU and LMTD vs outlet temperature of water

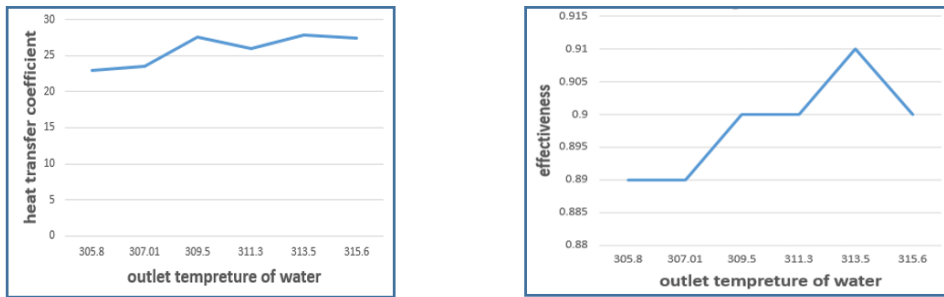

Figure 6.4: heat transfer coefficient and effectiveness vs outlet temperature of water

Our Main Objective

Our main objective is to design a system which can give us high heat transfer rate, As you can see the increase of heat transfer rate due to the outlet temperature of the system in following fig()

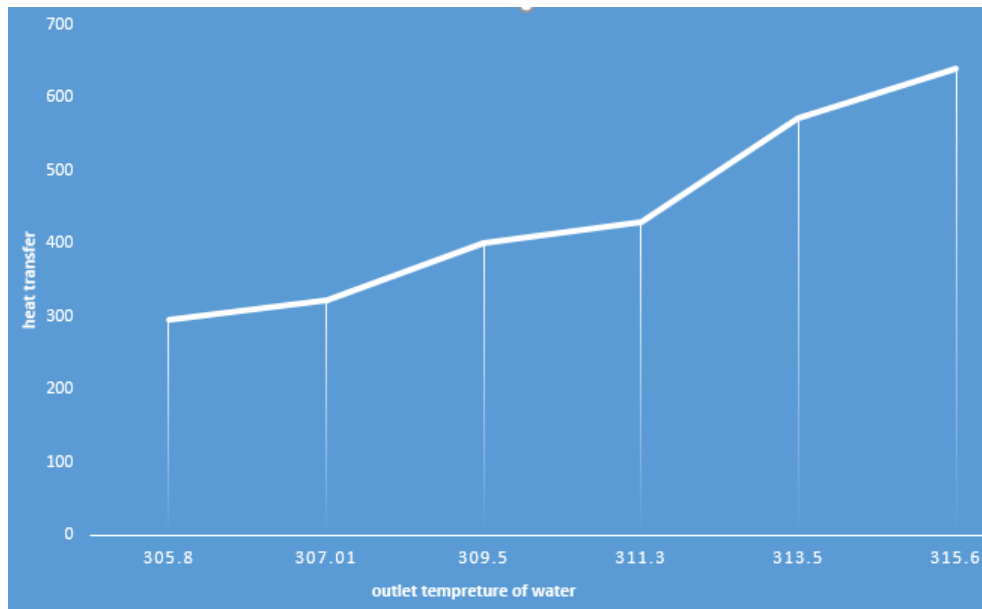

Figure 6.5: Heat Transfer Rate Vs Outlet Temperature of water

Conclusion

In the present study, theoretical model is developed and predictions from the developed model are compared with experimental results obtained from engine using optimized EGR cooler. The result indicates that

1. When testing the heat ex-changer under the counter flow with segmental different baffle, we have noticed that more heat transfer is observed when the hot water flows in the tubes as compared to the condition in which it has flown through the shell.

2. The effectiveness of heat ex-changer having disc and doughnut type is more than segmental baffle type ,this may be due to increase in the of heat transfer area there by increase in the rate of cooling.

3. The Logarithmic mean temperature difference is also one of the important criteria for evaluating the performance of heat ex-changer. This may be due to increase in flow rate of fluid over this tubes , this further increases the heat transfer rate. Higher LMTD means higher heat transfer rate.

4. The increase in heat transfer rate is due to the increase in turbulence of fluid. It is seen that more turbulence is created in Segmental baffles.

5. As the engine speed increases there is increase in temperature of exhaust gas and pressure drop across EGR cooler.

6. It has been also observed that as engine speed increases there is increase in CO,HC emission.

7. It has also observed by comparison of result that at higher speed there is decrease in NOx emission even though higher exhaust gas temperature. More PM is produced at the lower exhaust gas temperature than at the high temperature. Thus, the EGR system has a trade-off between NOx and PM emission. Further studies with this trade-off in consideration can improve the EGR cooler design and meet the stringent emissions legislation imposed on the future diesel engine.

Recommendation for future researchers

To further enhance the heat transfer and pressure drop performance of EGR novel techniques can be implemented such as incorporating the various shapes and types of fins (such as rectangular, triangular, and airfoil) and novel corrugation on outer surface of tubes, using inclined baffles and modifying shape of tubes etc.

Reference

1. Ghassembaglou, N. and L. Torkaman, Efficient design of exhaust gas cooler in cold EGR equipped diesel engine. Alexandria Engineering Journal, 2016. 55(2): p. 769-778.
2. Jang, S., et al., Experimental investigation of the influences of shape and surface area on the EGR cooler efficiency. Heat and Mass Transfer, 2011. 47(6): p. 621-628.
3. Kim, H.-M., et al., An experimental study on heat exchange effectiveness in the diesel engine EGR coolers. Journal of Mechanical Science and Technology, 2008. 22(2): p. 361-366.
4. Kim, H.-M., et al., Investigation on the flow and heat transfer characteristics of diesel engine EGR coolers. International Journal of Automotive Technology, 2008. 9(2): p. 149-153.
5. Abd-Elhady, M., et al., Influence of gas velocity on particulate fouling of exhaust gas recirculation coolers. International Journal of Heat and Mass Transfer, 2011. 54(4): p. 838-846.
6. Abd-Elhady, M. and M. Malayeri, Asymptotic characteristics of particulate deposit formation in exhaust gas recirculation (EGR) coolers. Applied Thermal Engineering, 2013. 60(1-2): p. 96-104.
7. Jang, S.-H., et al., Effects of PM fouling on the heat exchange effectiveness of wave fin type EGR cooler for diesel engine use. Heat and Mass Transfer, 2012. 48(6): p. 1081-1087.
8. Sanghoon Jang • Sangki Park • Kapseung Choi • Hyungman Kim.” Experimental investigation of the influences of shape and surface area on the EGR cooler efficiency”
9. Melgar, A. Horrillo and G. Cabaco Foundation CIDAUT (Center for Automotive Research and Development) (Spain) C. Castaño and J. A. Grande DAYCO ENSA S.L. (Spain)
10. Technical School, P.O. Box 17835, Al-Ain, United Arab Emirates. Received 17 January 2001; accepted 25 April 2001 “Using exhaust gas recirculation in internal combustion engines: a review G.H. Abd-Alla”
11. Ladommatos N, Abdelhalim SM, Zhao H, Hu Z. The effects of carbon dioxide in exhaust gas recirculation on Diesel engine emission. Proc Instn Mech Engng part D J Autom Engng 1998;212:25-42

12. Beatric C et al. Influence of high EGR rate on emissions of a DI Diesel engine. ASME ICE Div 1998;IC 22:193–201.
13. Reader GT, GalinskyG, Potter I, Gustafson RW. Combustion noise levels and frequency spectra in an IDI Diesel engine using modified intake mixtures. Emerging Energy Technol Trans ASME 1995;66:53–8.
14. Unchide N et al. Combined effects of EGR and supercharging on Diesel combustion and emissions. Diesel Combustion processes, SAE 930601, 1993.
15. Heywood JB. Internal combustion engine fundamentals. New York: McGraw-Hill; 1998.
16. Mozafari A. Exhaust gas recirculation in spark ignition engine. Adv Heat Trans ASME 1994;PD64(1):197–202.