

# **Design, Construction and study of performance of a flat-plate solar heater for winter air conditioning of a small residential building in Bangladesh.**

**BY**

**Mahmud Arefin Haq (091416)**

**Adib bin Rashid (091432)**

**SUPERVISED BY**

**Professor Dr. A.K.M. Iqbal Hussain**

A thesis submitted to the Department of Mechanical & Chemical  
Engineering (MCE) in partial fulfillment of the requirement for the degree of  
Bachelor of Science in Mechanical Engineering

بِسْمِ اللَّهِ الرَّحْمَنِ الرَّحِيمِ



**Department of Mechanical & Chemical Engineering (MCE)**

**ISLAMIC UNIVERSITY OF TECHNOLOGY (IUT)**

**October, 2013**

# CANDIDATES' DECLARATION

It is hereby declared that this thesis or any part of it has not been submitted elsewhere for the award of any degree or diploma.

**Signature of the Candidate**

---

**Mahmud Arefin Haq**

**Student No. 091416, Session 2009-2010**

**Department of Mechanical & Chemical Engineering  
(MCE)**

**Islamic University of Technology (IUT), OIC**

**Signature of the Candidate**

---

**Adib Bin Rashid**

**Student No. 091432, Session 2009-2010**

**Department of Mechanical & Chemical Engineering  
(MCE)**

**Islamic University of Technology (IUT), OIC**

**Signature of the Supervisor**

---

**Professor Dr. A.K.M. Iqbal Hussain**

**Supernumerary Professor**

**Department of Mechanical & Chemical Engineering (MCE)**

**Islamic University of Technology (IUT), OIC**

**Board Bazar, Gazipur**

# ACKNOWLEDGEMENT

We express our heartiest gratefulness to Almighty Allah for His divine blessings, which made us possible to complete this thesis successfully.

First and foremost, we feel grateful and acknowledge our profound indebtedness to, Professor Dr. A.K.M. Iqbal Hussain, Supernumerary Professor, Department of Mechanical and Chemical Engineering, IUT. His endless patience, scholarly guidance, continual encouragement, constant and energetic supervision, constructive criticism, valuable advice at all stage has made it possible to complete this project. Special thanks to Md. Abu Hossain Senior Operator (Air conditioning & refrigeration Lab), IUT for their useful suggestions and cooperation without which this project implementation would not have been possible. We would also like to offer thanks to all who contributed us in many ways during the project work. Finally, thanks goes to our friends and families whose inspirations kept us going on with this project successfully.

In particular, we are thanking our parents and friends for their emotional support and encouragement, as through them, I found the motivation and focus to complete this project.

We seek excuse for any errors that might be in this report despite our best efforts.

# ABSTRACT

Rising costs of conventional fuels, increasing energy demand, concerns over climate change and pollutants resulted from burning fossil fuels have increased the interest in various renewable energy technologies. The energy demand associated with heated air for different sectors is quite significant. Solar air heaters have been developed with the aim of reducing the demand for conventional fuels. This Thesis presents design and technical evaluation of solar air heating system on a small residential building in Bangladesh for winter air conditioning. It is estimated that for heating of 3m x 3m x 3.5m of room, a collector of 1.5m<sup>2</sup> is needed with proper insulation of 2 inch thick Fiber glass. For the surface coating (generally black) on a mild steel sheet a selective coating system is suggested. For the distribution of air in the conditioned space a blower of Pressure 55mm (water), 1400 RPM, Frequency 50Hz, air velocity of 12 m/s and air capacity of .4 m<sup>3</sup>/s is used. A double glazing system is used to minimize the heat losses from the collector plate, which occur due to convection and radiation. The experimental work was performed beside the middle workshop, Mechanical Engineering Department, Islamic University of Technology under Gazipur prevailing weather conditions during the summer months August and September. Data were collected on half an hour interval from 9.00 am to 5.00 pm. As the ground was flat, the collector was proposed to be tilted with 23.5°. The outlet, T<sub>out</sub>, and the inlet, T<sub>in</sub>, temperatures were measured by using T- type thermocouples and the global solar radiation incident on an inclined surface was measured by using a Pyranometer.

**Keywords:** Renewable energy, Human comfort, winter air conditioning, Solar air heaters, thermal efficiency.

## LIST OF SYMBOLS/ABBREVIATIONS

$SAH$	Solar air heater
$A_c$	Area of the collector ( $m^2$ )
$C_p$	Specific heat of air ( $kJ/kg \cdot K$ )
$I$	Solar radiation ( $w/m^2$ )
$m$	Air mass flow rate ( $kg/s$ )
$T_{out}$	Outlet temperature (K)
$T_{in}$	Inlet temperature (K)
$T_f$	the film air temperature between the outlet and inlet $(T_{out} + T_{in})/2$
$\Delta T$	Temperature difference $(T_{out} - T_{in})$ (K)
$\Delta T_b$	Bed temperature difference $(T_b - T_{in})$ (K)
$\Delta T_g$	Glass temperature difference $(T_g - T_{in})$ (K)
$\eta$	Efficiency of the solar collector
$Q$	Volume flow rate ( $m^3/s$ )
$\rho$	Density of air ( $kg/m^3$ )
$\Delta P$	Pressure difference, ( $N/m^2$ )
$g$	Gravitational acceleration ( $m/s^2$ )

# **Table of Content**

<b>1.Solar Energy and Its Availability .....</b>	<b>7</b>
<b>2.Solar Energy Utilization.....</b>	<b>7</b>
<b>3.Types of Solar Heaters .....</b>	<b>7</b>
<b>4.Solar Air Heater (SAH) .....</b>	<b>7</b>
<b>5.Summary of procedure for estimating heating loads.....</b>	<b>8</b>
<b>6.Heat loss for single room.....</b>	<b>9</b>
<b>7.Area of flat plate collector considering heat loss.....</b>	<b>14</b>
<b>8.Calculation of pressure loss.....</b>	<b>15</b>
<b>9.Determination of collector efficiency .....</b>	<b>17</b>
<b>10.DESIGN OF SOLAR AIR HEATING SYSTEMS.....</b>	<b>18</b>
<b>11.PERFORMANCE TEST AND RESULTS ANALYSIS.....</b>	<b>19</b>
<b>12.Experimental Procedure .....</b>	<b>19</b>
<b>13.Data Collection.....</b>	<b>25</b>
<b>14.Suggestions for Future Work .....</b>	<b>28</b>
<b>15.REFERENCES .....</b>	<b>29</b>
<b>16.Appendix .....</b>	<b>31</b>

## **Solar Energy and Its Availability**

Solar energy could directly provide all the necessary energy requirements for human need. If it could be collected from only 1% of the earth's surface, the human population's power supply could be entirely supplied directly by the sun (Kalogirou, 2009). Solar radiation available to the earth's surface is also much less than the radiation available outside the earth's atmosphere. Approximately 25-50% of the solar radiation outside the earth's outer atmosphere is lost upon entering it. The greenhouse gases and water vapor reflect and absorb much of the energy radiated to the earth. (Goswami et al. 2000)

## **Solar Energy Utilization**

The emergence of interest in solar energy utilization has taken place since 1970, principally, due to the rising cost of energy from conventional sources. Solar radiation is the world's most abundant and permanent energy source. There are many areas where the solar energy is obviously used such as:

- Industrial process heating
- Electricity generation (Solar thermal power plant, photovoltaic systems)
- Greenhouse heating
- Swimming pool heating
- Domestic hot water heating : Evacuated-tube solar collectors, integral collector- storage systems, flat-plate collector
- Space heating and cooling

## **Types of Solar Heaters**

Solar heater is simply a system that absorbs solar energy by using its available surface area to capture the sun's radiation. Different methods are used in classifying solar heaters. One of these classifications is based on the working fluid as an example of water solar collectors and air collectors or alcohol solar collectors. Another classification depends on the application of the solar collector such as domestic use and industrial use. In literature, some classifications can be found based on their mechanism and design such as fixed and movable solar collectors or single path and double path or single glazing and double glazing. Others divided the collectors based on the absorber plate and solar traction system such as concentrated or flat collectors.

As a result of this, there is no rigid classification that can be used in our research. However, as it will be seen soon in this thesis, the classifications that are used are either the design of the absorber plate or the flow direction of used air.

## **Solar Air Heater (SAH)**

Conventional solar air heaters mainly consist of panels, insulated hot air duct and air blowers in active systems, without having blower in the passive system. The panel consists of an absorber plate and one or two transparent covers to allow solar radiation to penetrate into the collector. The plate of SAH (usually painted with the black color to maximize absorption) absorbs the solar radiation, and then transfers the heat to a fluid.

The working fluid flows through the SAH over the plate, thereby collecting the heat absorbed by the plate via convection.

SAHs are cheap and extensively used. It has wide range of application such as delivering heated air at low to moderate temperatures for space heating, drying agricultural products (i.e., fruits, seeds and vegetables), and in some industrial applications (Akpınar et al., 2004).

SAHs are environmentally friendly, i.e., pollution free, sustainable, financially competitive, and safe (flammability and explosively). The SAHs have different advantages compared to water solar collectors such as SAHs are free of freezing, corrosion, or leakage problems. Typical flat plate collectors can obtain outlet fluid temperatures of around 70 °C. The thermal efficiency of these collectors depends on the working fluid, but simple flat plate solar heaters can have efficiencies of about 60% for solar water heaters (SWHs), and about 40% for SAHs for normal operating conditions (Goswami et al. 2000).

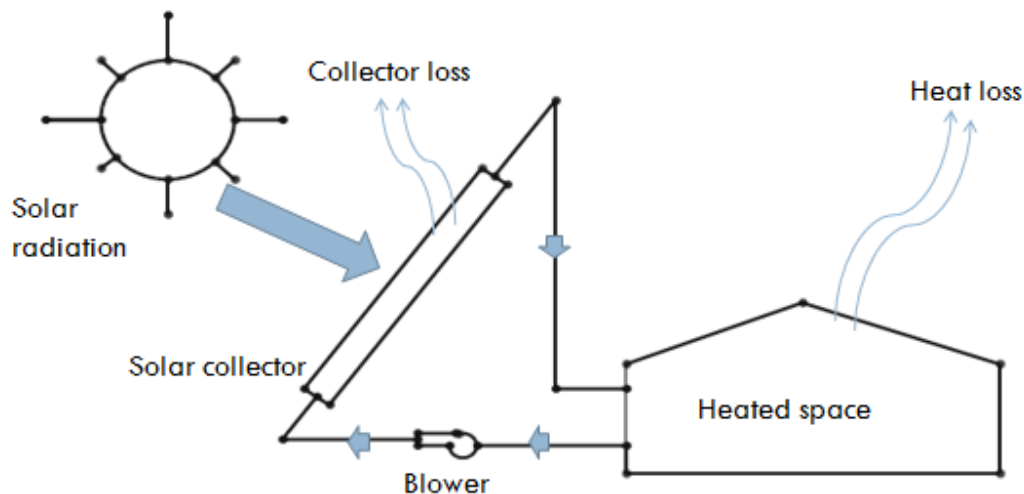

Figure: system diagram of air heater

### Summary of procedure for estimating heating loads:

In estimating the heating loads for a building, it is important to use an organized, step-by-step procedure. The necessary steps can be outlined as follows:

1. Select design values for outdoor winter design (97.5 percent value)
2. Select an indoor design temperature appropriate to the activities to be carried out in the space and a minimum acceptable relative humidity.
3. Determine Estimate temperatures in the unconditioned spaces as necessary.



4. On the basis of building plan and specifications, calculate heat-transfer coefficients and areas for the building components in each enclosing surface. Any surfaces connecting with spaces to be maintained at the same temperature may be omitted. i.e., interior wall.
5. On the basis of building components, system design and operation, wind velocity, ventilation outside air. Note that the latent component of the infiltration and/or ventilation lode is included only if the conditioned air is to be humidification to maintain a specified minimum indoor humidity level. Humidification is often omitted from air-conditioning systems in mild climates.
6. Using the above design data, compute transmission heat losses for each surface of the building envelope and the heat loss from infiltration and/or ventilation. Sum these values to determine the total estimated heat loss and required capacity of the heating equipment.

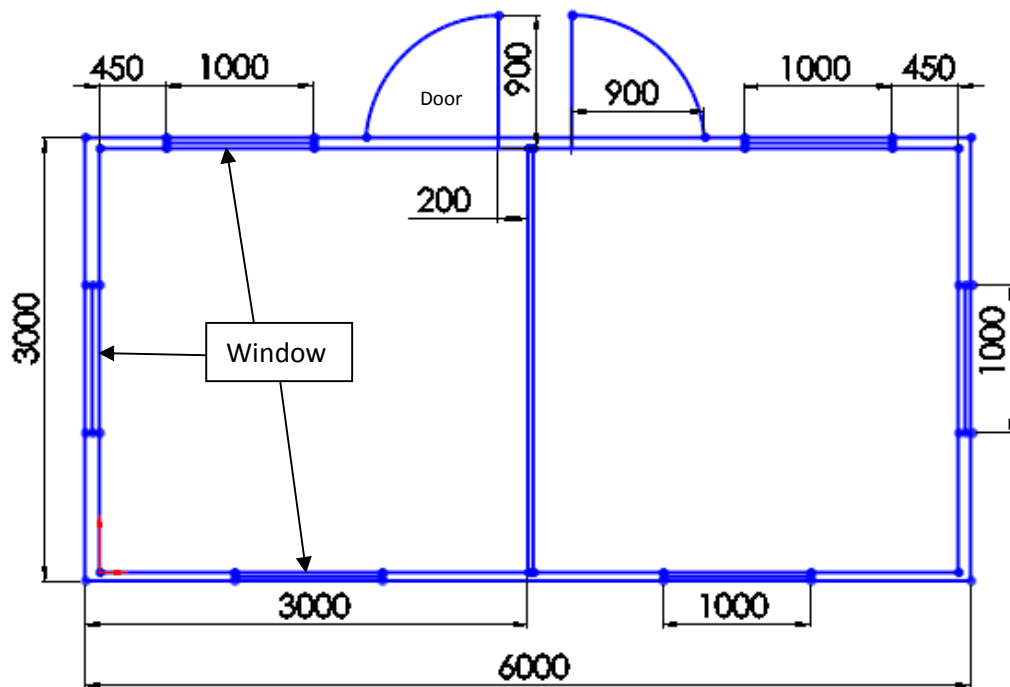

### Heat loss for single room:

$$\begin{aligned} \text{Area of window, } A_{w1} &= 3(2*1) \\ &= 6 \text{ m}^2 \end{aligned}$$

$$\text{Area of door, } A_d = 0.9*2.1$$

$$= 1.89 \text{ m}^2$$

$$\text{Area of wall, } A_w = (3*3)*2 + (2*3) - 6 - 1.89$$

$$= 16.11 \text{ m}^2$$

$$\text{Area of floor, } A_f = 3*2$$

$$= 6 \text{ m}^2$$

### **Heat loss for window:**

Window material = Single sheet common glass

Heat transfer coefficient,  $U = 6.2 \text{ W/m}^2\text{k}$

Here,

Inside temp,  $t_i = 22\text{C}$

Outside temp,  $t_o = 10\text{C}$

$$\begin{aligned} \text{So, Heat loss through window, } Q_w &= UA (t_i - t_o) \\ &= 6.2 * 6 (22 - 10) \\ &= 446 \text{ W} \end{aligned}$$

If shading coefficient = 0.2

$$\begin{aligned} \text{So, Heat loss through window, } Q_w &= 446 * 0.28 \\ &= 124.8 \text{ W} \end{aligned}$$

### **Heat loss through door**

Door material = Wood (3cm thick)

$$U = 2.94 \text{ W/m}^2\text{k}$$

$$\begin{aligned} \text{So, Heat loss through Door, } Q_d &= UA (t_i - t_o) \\ &= 2.94 * 1.89 (22 - 10) \\ &= 66.68 \text{ W} \end{aligned}$$

### **Heat loss through wall:**

Wall material = a. Common brick (14cm thick)

For, Common brick, Heat transfer coefficient,  $U = 1.7 \text{ W/m}^2\text{k}$

$$\begin{aligned}
 \text{So, Heat loss through wall, } Q_w &= UA_w(t_i-t_o) \\
 &= 1.7*16.11*12 \\
 &= 328 \text{ W}
 \end{aligned}$$

### Heat loss through roof:

For built up roofing, 10mm, Heat transfer coefficient,  $U = 1.7 \text{ W/m}^2\text{k}$

$$\begin{aligned}
 \text{So, Heat loss through roof, } Q_R &= UA(t_i-t_o) \\
 &= 1.7*6*12 \\
 &= 122 \text{ W}
 \end{aligned}$$

### Heat loss through floor:

Heat transfer coefficient,  $U = 0.5 \text{ W/m}^2\text{k}$   
 Temperature difference,  $dT = 5^\circ\text{C}$

$$\begin{aligned}
 \text{So, Heat loss through floor, } Q_F &= UAdT \\
 &= 0.5*6*5 \\
 &= 15 \text{ W}
 \end{aligned}$$

### Infiltration heat loss:

Wind velocity,  $v = 6.7 \text{ m/s}$

$$a = 0.2$$

$$b = 0.015$$

$$c = 0.014$$

$$\begin{aligned}
 \text{Number of air changes, } n &= a+b^2+c(t_o-t_i) \\
 &= 0.2+0.015^2+0.014(10-22) \\
 &= 0.1325 \text{ per hour}
 \end{aligned}$$

Again,  $n = V_{inf}/V_{room}$

$$\text{So, } 0.1325 = V_{inf}/3.5*3.5*3$$

$$V_{inf} = 4.87 \text{ m}^3/\text{h}$$

$$= 1.35*10^{-3} \text{ m}^3/\text{s}$$

$$\begin{aligned}
 Q_{\text{Sinf}} &= V_{\text{inf}}/V_o * C_{\text{pm}} * (t_i - t_o) \\
 &= (1.353 * 10^{-3} / 0.812) * 1.027 * 12 * 1000 \\
 &= 20.53 \text{ W}
 \end{aligned}$$

### **ventialtion heat loss:**

Ventilation air rates = 2.5 l/s per person

$$\begin{aligned}
 Q_{\text{Sven}} &= V_{\text{ven}}/V_o * C_{\text{pm}} * (t_i - t_o) \\
 &= (2.5/1000) / 0.812 * 1.027 * 1000 * 12 \\
 &= 38 \text{ W}
 \end{aligned}$$

### **Total heat loss:**

$$\begin{aligned}
 \text{Total Heat loss, } Q &= Q_w + Q_d + Q_w + Q_R + Q_f + Q_{\text{Sif}} + Q_{\text{Sven}} \\
 &= 328 + 66 + 124 + 122 + 15 + 20 + 38 \\
 Q &= 650 \text{ W}
 \end{aligned}$$

### **7.1.9 Inside design condition:**

$$T_{\text{db}} = 22^{\circ}\text{C}$$

$$T_{\text{wb}} = 15^{\circ}\text{C}$$

$$\text{Supply air} = 36^{\circ}\text{C}$$

## Outside design condition:

$$T_{db} = T_{wb} = 10^{\circ}\text{C (saturated)}$$

Now, from psychometric chart,

$$\text{RH} = 47\%$$

$$V_s = 0.883 \text{ m}^3/\text{kg}_a$$

Now,

$$Q_{\text{loss}} = V_s/V'_s * C_{ps} (t_{\text{supply}} - t_{\text{room}})$$

$$650 = V_s/0.883 * 1.027 * 1000(36-22)$$

$$V_s = 0.04 \text{ m}^3/\text{s}$$

$$V_s = 2.3 \text{ m}^3/\text{min}$$

$$V_s = 143 \text{ m}^3/\text{hour}$$

$$\text{Heating Capacity, } Q_h = 650\text{W} = 6.50 \text{ KW}$$

$$\text{Increasing by 5\%, } Q_h = 650 * 1.05$$

$$= 682\text{W}$$

## Design consideration for solar collector

Useful heat loss through the solar panel =  $M_a * C_{pa} * (T_2 - T_1)$

$$= 0.039 / 0.883 * 1027(36 - 21)$$

$$= 680 \text{ W}$$

$$Q_u = Q_T - 0.04Q_T - Q_{\text{loss}}$$

$$680 = Q_T * 0.96 + 0$$

$$Q_T = 700 \text{ W}$$

$$\text{Again, } I_t * A = Q_T$$

$$600 * A = 700$$

$$\text{Area of collector, } A = 1.18 \text{ m}^2$$

### Area of flat plate collector considering heat loss:

$$\begin{aligned} \text{Total area for wooden frame, (lower part), } A_w &= (1.3 \times 0.9) + (0.09 \times 2) + (0.18 \times 4) \\ &= 1.35 \text{ m}^2 + (0.09 \times 2) + 0.18 \\ &= 1.35 \text{ m}^2 + 0.18 + 0.18 \\ &= 1.71 \text{ m}^2 \end{aligned}$$

Height of frame is 250 mm

$$\begin{aligned} \text{So wood for side} &= 1.5 \times 0.1 + (0.038 \times 4) \\ &= 0.302 \text{ m}^2 \end{aligned}$$

$$\text{So, total wood, } A_w = 1.71 + 0.302 = 2.012 \text{ m}^2$$

$$\text{Area for glass, } A_g = 1.5 \times 0.9 = 1.35 \text{ m}^2$$

Area for insulation,  $A_i = 2.012 \text{ m}^2$

Heat loss through wood,  $Q_w = UA$  (36- 19)

$$= 2.94 \times 2.012 \times 17$$

$$= 100.55 \text{ W}$$

Heat loss through glass (Double glass)  $Q_g = UA$  (36- 19)

$$= 2.8 \times 1.35 \times 17$$

$$= 64.26 \text{ W}$$

Heat loss through insulation, (glass fiber),  $\frac{1}{U} = R_i + \frac{x}{k} + R_o$

$$= 0.12 + (0.02 \times 27.7) + 0.029$$

$$= 0.964$$

So,  $U = 1.04 \text{ W/m}^2\text{K}$

So,  $Q_i = UA$  (36-19)

$$= 1.04 \times 2.02 \times 17$$

$$= 35.714 \text{ W}$$

So total heat loss  $Q = 100.55 + 64.26 + 35.714$

$$= 200.52 \text{ W}$$

$$Q_u = Q_T - 0.04Q_T - Q_{\text{loss}}$$

$$680 = Q_T * .96 - 200.52$$

$$Q_T = 917.21 \text{ W}$$

Again,  $I_t * A = Q_T$

$$600 * A = 917.21$$

Area of collector,  $A = 1.5 \text{ m}^2$

## Calculation of pressure loss:

Velocity of air = 12 m/s

Density of air at 20°C = 1.2041 kg/m<sup>3</sup>

$$A_1 = (\pi/4)(0.45)^2 = 1.6 \times 10^{-3} \text{ m}^2$$

## Sudden Contraction

$$\begin{aligned} p_{\text{loss1}} &= \frac{V_1^2}{2} \rho \left(1 - \frac{A_1}{A_2}\right)^2 \\ &= \frac{12^2}{2} \times 1.2041 \left(1 - \frac{1.6}{7.854}\right)^2 \\ &= 55 \text{ Pa} \end{aligned}$$

$$\begin{aligned} p_{\text{loss2}} &= \frac{V_2^2}{2} \rho \left(1 - \frac{A_2}{A_3}\right)^2 \\ &= \frac{12^2}{2} \times 1.2041 \left(1 - \frac{7.854 \times 10^{-3}}{0.09}\right)^2 = 18 \text{ Pa} \end{aligned}$$

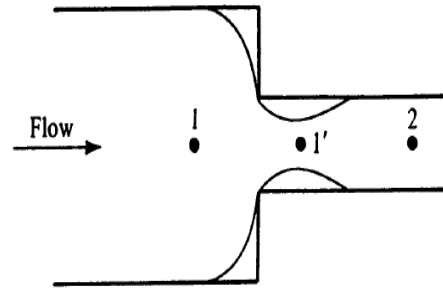

Figure: Sudden Contraction

## Sudden enlargement:-

$$p_{\text{loss3}} = \frac{V_3^2}{2} \rho \left(\frac{1}{C_C} - 1\right)^2 \dots\dots\dots(1)$$

$$\begin{aligned} \frac{A_4}{A_3} &= \frac{7.854 \times 10^{-3}}{0.09} \\ &= 0.09 = 0.1 \end{aligned}$$

From table  $C_C = 0.624$

$$\left(\frac{1}{C_C} - 1\right)^2 = 0.366$$

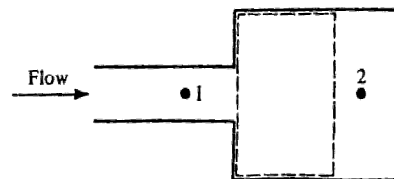

Figure: Sudden enlargement



From (1) we get,

$$p_{\text{loss3}} = \frac{4^2}{2} \times 1.204 \times 0.366$$
$$= 3.5 \text{ Pa}$$

Pressure of blower = 55 mm of H<sub>2</sub>O

$$= 55 \times 9.81 \text{ P}$$

$$= 539.55 \text{ Pa}$$

So pressure on outlet = 540-55-18-3.5

$$= 463 \text{ Pa}$$

$$= 47 \text{ mm of H}_2\text{O}$$

### **Determination of collector efficiency:-**

Solar irradiation,  $I_{i\theta} = 600 \text{ W/m}^2$

Area of collector,  $A = 1.5 \text{ m}^2$

Transmittance of each of the two cover plate,  $\tau_{c1} = \tau_{c2} = 0.87$

Mild steel absorber plate has,  $\alpha = 0.92$

Ambient temperature,  $t_a = 10^\circ\text{C}$

Overall heat transfer co-efficient,  $U = 3.5 \text{ w/m}^2\text{k}$

Surface temp of absorber,  $t_{ai} = 45^\circ\text{C}$  (assuming)

$F_r$  = empirically determined correction factor = 0.9

We know,

$$\eta = \frac{q_a/A}{I_{i\theta}} = (\tau_{c1} \tau_{c2} \alpha_a - \frac{U(t_{ai} - t_a)}{I_{i\theta}}) F_r$$
$$= (0.87 \times 0.87 \times 0.92 - \frac{(45-10)3.5}{600}) \cdot 0.9$$
$$= 0.443$$

So  $\eta = 44\%$

## DESIGN OF SOLAR AIR HEATING SYSTEMS

### Introduction

The design of a solar air heating systems for a particular application requires the trade off study between efficiency, fan power requirement, desired operation temperature, array size, air ducting and total air volume to be handled. The detail design consideration for solar air collector is illustrated as below: The design can be broken into its components for the sake of analysis. The identification of the possible material and selection of the components which best meet the requirements play an important role. The components taken for the evaluation were Absorber plate, Absorber coating, Glazing and insulation.

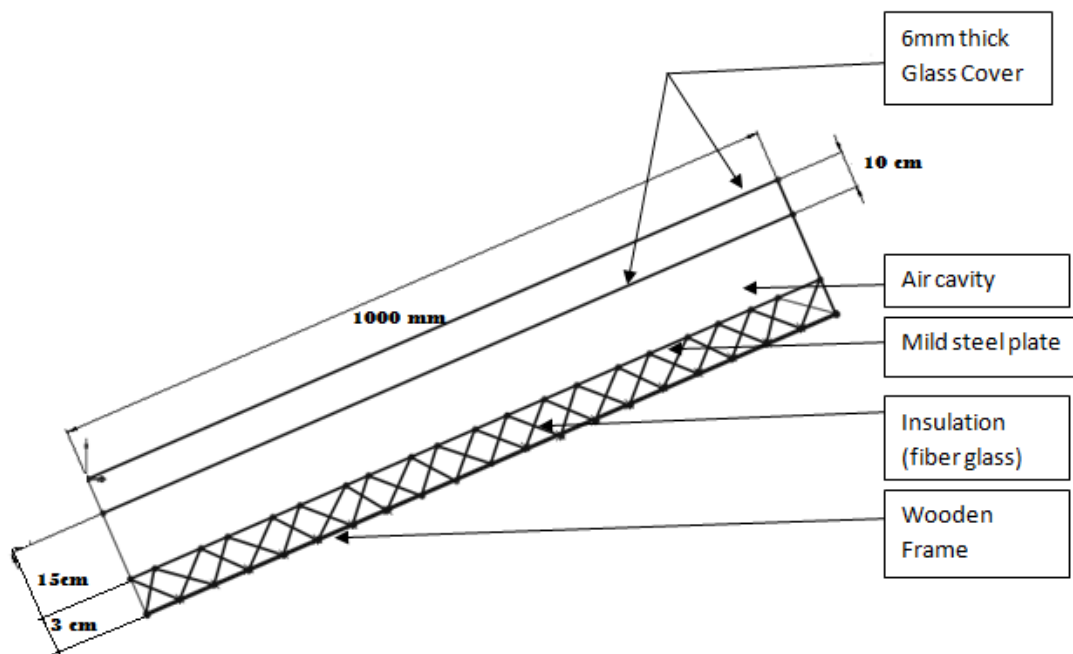

Figure: Design concept of Solar air heater

### Absorber plate

The solar radiation incident on the absorber plate, raises its temperature. This thermal energy is transferred to the working fluid. The design requirements for the absorber plate taken into consideration are operating temperature range, maximum stagnant temperature, operating flow rate and cost etc. Considerable research has been done on absorber plate materials and their properties. The most common plate materials are metals like copper, aluminum and iron. Among these, copper is the best material due to its thermal conductivity which is  $0.18 \text{ w/m}^\circ\text{C}$ , specific heat  $0909 \text{ cal/gm}^\circ\text{C}$  and it is highly resistant to corrosion. Its melting point and boiling points are  $1083^\circ\text{C}$  and  $2380^\circ\text{C}$  respectively.

### **Absorber coating**

A surface coating (generally black) is placed on the absorber plate to maximize the absorption of solar energy. The quality of the coating should be such that it absorbs maximum energy and emits the minimum. An ordinary blackened surface absorbs maximum solar radiation but its emittance is also high. Thus, it is not suitable for high temperature applications. For efficient solar air collectors selective coating technique is used for absorber coating.

### **Glazing or cover plate**

The primary function of the cover plate or glazing is to minimize the heat losses from the collector plate, which occur due to convection and radiation. The cover plate must have the following properties:

- a) High transmittance in for solar radiation visible range (low refraction).
- b) Low transmittance for thermal radiation ranges (high refraction).
- c) Low absorptance at all wave lengths.
- d) Excellent weather ability and durability.

A number of transparent materials can be used for cover plate. Glass is more frequently used than plastic, or any other material. Though it is very brittle, it is resistant to most alkalis and chemicals. It has uniform transmittance of 90% and absorptance 6% in visible part and is virtually opaque in the infra red range

### **Insulation**

Insulation is an important factor playing a very significant role in minimizing the heat losses from the lower surface of the collector plate and from the lateral edges of the collector. If insulation is provided, then heat losses become the function of thermal conductivity of the insulating material and its thickness. The good design requirement for an insulation material in a collector include low thermal conductivity, no degradation, no out gassing or fuming at high temperatures of approximately 200 C and due to repeated thermal cycling up to 150C and being hydrophobic. Glass wool or rock wool can be used for this purposes.

### **Bottom ,Side Frame**

The body of the solar panel generally made by aluminum for its low weight, high strength and durability. Aluminum also increases the aesthetic look of the panel. The assembly of aluminum frame is also very easy. But as its cost is high wood is more preferable for research work on solar panel.

### **Specifications of solar air heating collectors**

The specification of solar air collector is tabulated in between the absorber and the outer cover has been proposed to reduce internal convection and conduction, but the cost of added supports and maintenance of a vacuum are excessive.

**Table1. Specification of Solar Air heating collector**

SI. No.	Components	Specification
1	Size Glazing Absorber	1.5 m <sup>2</sup> double Glazing : 6mm
2	Plate Absorber	1.5 m <sup>2</sup> Sheet metal (Iron)
3	Absorber Coating	Selective Coating
4	Insulation	Fiber glass
5	Bottom ,Side Frame	Wood (kerosene)
6	Sealant	Neoprene Silicon base sealant
7	Duct Connector at either both ends.	Male / Female type at one /both ends coupling with Gasket / sealant for increasing collector size

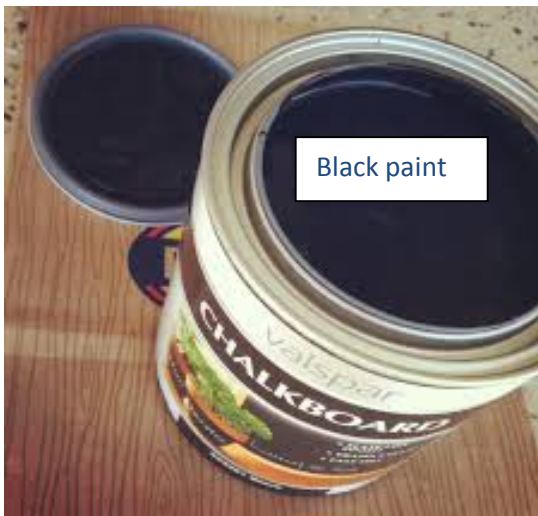
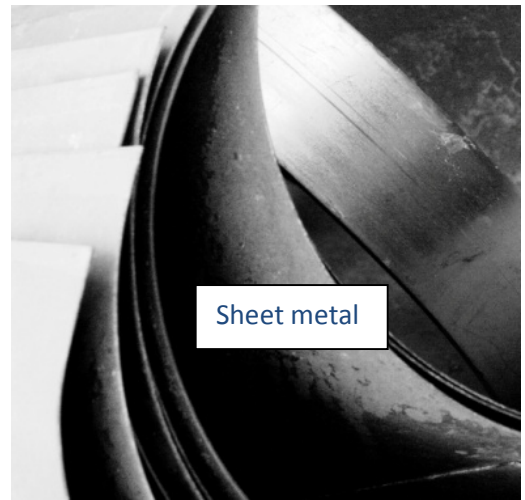
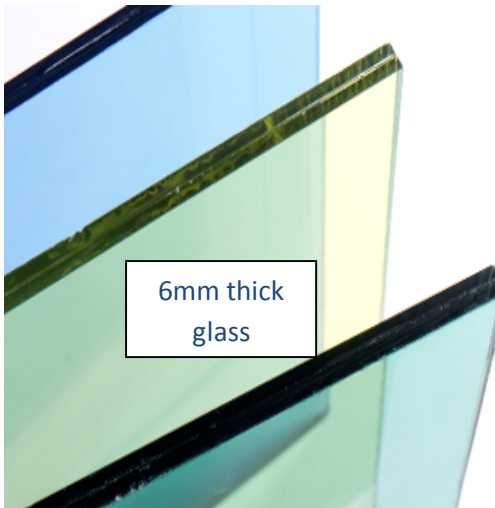

Figure: Components used in solar air heater

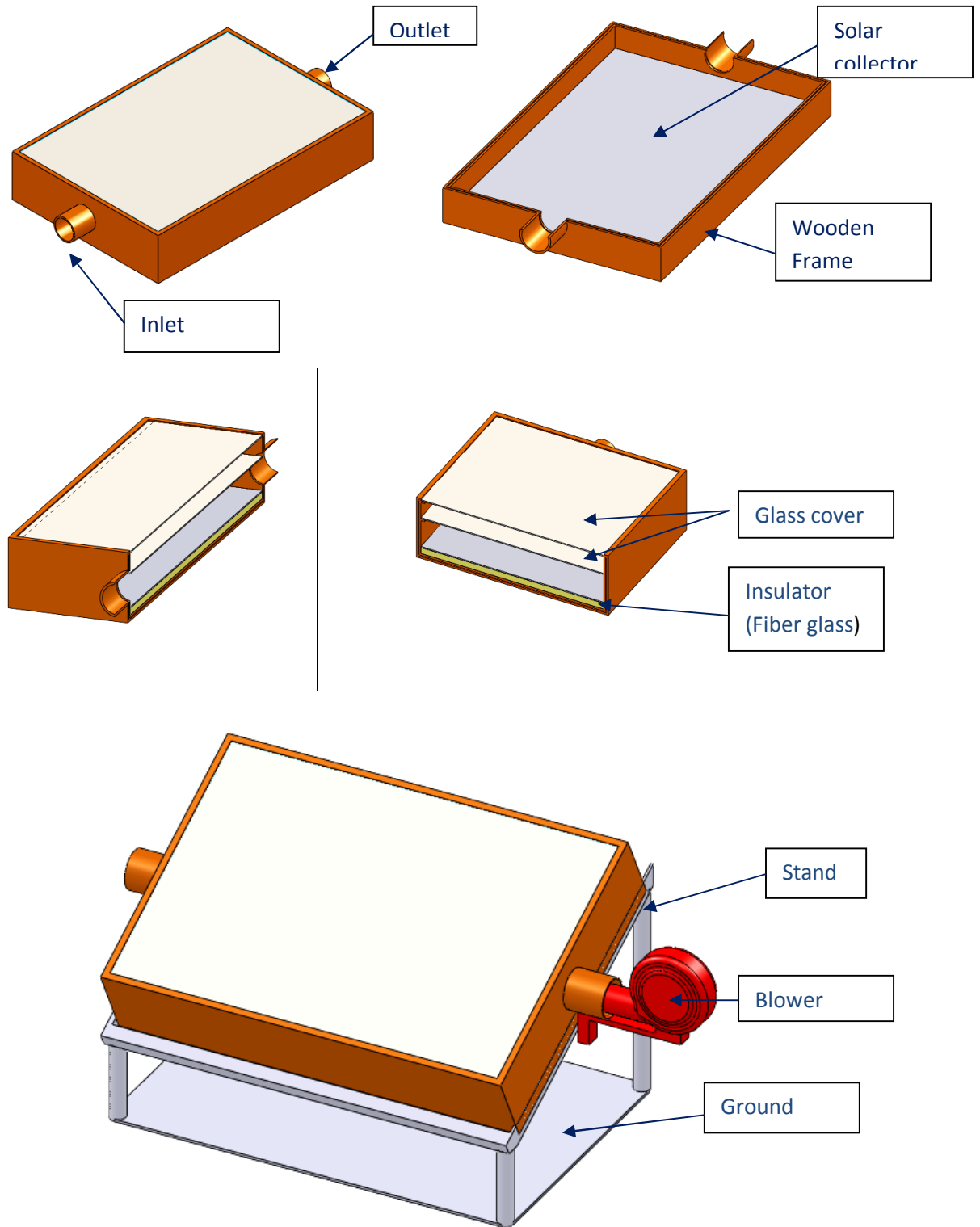

Figure : Cad model of the solar air heater

Table: Cost of the materials

Product	Amount	Price
1)Blower Fan	1 piece	4000/=
2)Wood for Fabrication(Mango Tree)	6 CFT(400tk per CFT)	2400/=
3)Glass	(5*3)*2 =30 square Feet 75tk per square Feet	2250/=
4)Mild steel sheet	1 piece(8*4=32 square Feet)	2000/=
5)Mild steel for Frame	12 feet *3	1500/=
6)Insulator	15 square feet	750/=
7)Sealant , Paint		2500/=
8)Others		2000/=
Total		17400/=

## PERFORMANCE TEST AND RESULTS ANALYSIS

### Experimental Procedure

The experimental work was performed beside the Middle workshop, Mechanical Engineering Department, Islamic University of Technology under Gazipur prevailing weather conditions during the summer months August and September. Data were collected on half an hour interval from 9.00 am to 5.00 pm. As the ground was flat, the collector was proposed to be tilted with  $23.5^{\circ}$

Generally, the sky in Gazipur was clear all through the month of May to August with cloudy or partially cloudy from time to time. To observe an accurate reflection of the SAH performance, the data which was collected during more consistent weather condition was studied and considered. However some days were ignored in the analysis because of the weather conditions. The instantaneous values i.e. average mean value of the wind speed and relative humidity ratio were taken from the city office was hourly recorded



The measured variables were:  $T_{in}$ ,  $T_{out}$ , wind speed, relative humidity ratio, solar intensity radiation, and the temperature of three different equal places along the collector.



Figure: experimental set up of solar air heater



## Data Collection

Following tables are showing the data of Inlet ( $T_{in}$ ) and outlet ( $T_{out}$ ) temperature, solar intensity of the days 24.08.2013(Saturday), 25.08.2013(Sunday), and 3.09.2013

24.08.2013 (Saturday)

**Table:** Solar Intensity, Inlet ( $T_{in}$ ) and outlet ( $T_{out}$ ) temperature of the day 24.08.2013(Saturday)

24.08.2013 (Saturday)

SI.No.	Time	Solar Intensity	Inlet Temperature	Outlet Temperature
1.	9.00	256.45	27.00	35.8
2.	9.30	268.56	27.4	36
3.	10.00	298	27.8	37
4.	10.30	354	28	37.4
5.	11.00	387	28.2	38
6.	11.30	427	28.9	38.3
7.	12.00	459	29.7	39
8.	12.30	510	30.0	39.4
9.	1.00	590	30.8	39.9
10.	1.30	637	31.2	40.7
11.	2.00	678	32	42.3
12.	2.30	645	32.3	43.5
13.	3.00	612	32.4	43.7
14.	3.30	567	31.6	43.2
15.	4.00	534	31.1	42.5
16.	4.30	498	30.5	42.1
17.	5.00	437	30.00	41.6

**Table:** Solar Intensity, Inlet ( $T_{in}$ ) and outlet ( $T_{out}$ ) temperature of the day 25.08.2013(Saturday)

25.08.2013 (Sunday)

SI.No.	Time	Solar Intensity	Inlet Temperature	Outlet Temperature
1.	9.00	311	28.2	39.5
2.	9.30	345.49	28.7	40.2
3.	10.00	359	28.8	40.5
4.	10.30	391	29.4	40.7
5.	11.00	479	30.1	40.8
6.	11.30	494	30.4	41.0
7.	12.00	535	31.2	41.7
8.	12.30	567	32.0	42.6
9.	1.00	589	32.3	42.8
10.	1.30	632	33.0	43.5
11.	2.00	687	33.4	43.8
12.	2.30	698	33.7	44.6
13.	3.00	654	33.6	46.9
14.	3.30	625	33.7	46.5
15.	4.00	597	33.2	46.0
16.	4.30	543	32.8	45.2
17.	5.00	501	32.3	44.3

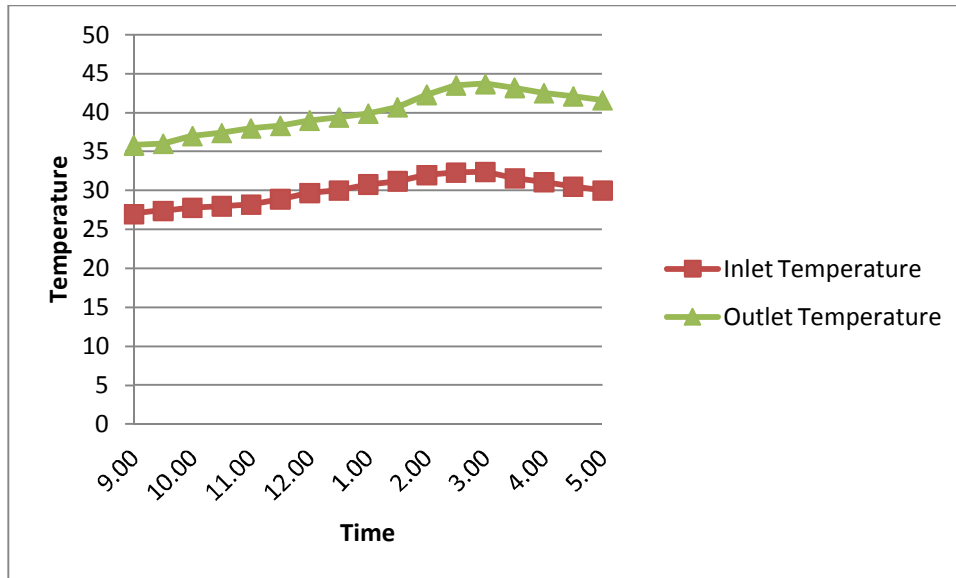

Figure: Chart of Temperature vs Time 24.08.2013 (Saturday)

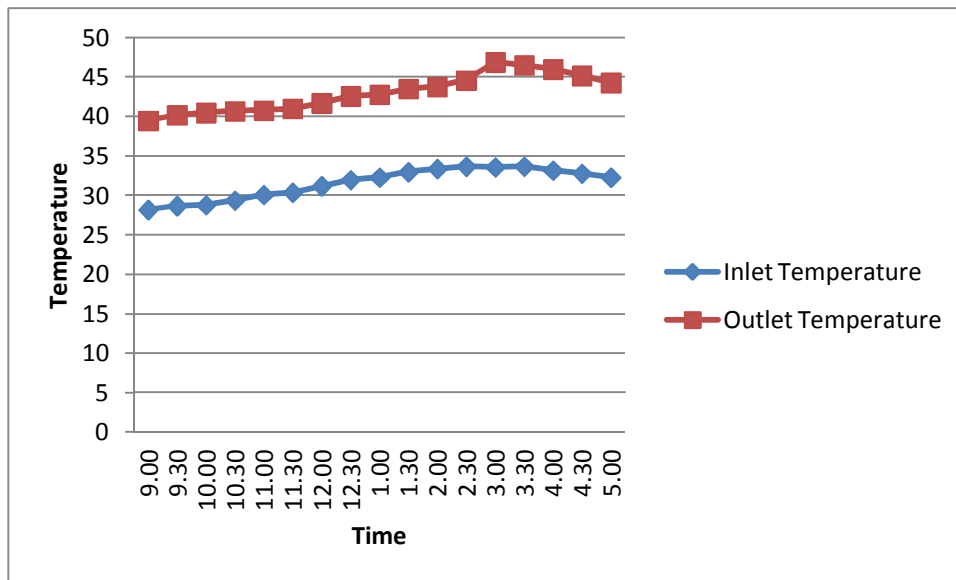

Figure: Chart of Temperature vs Time 25.08.2013 (Sunday)

## Suggestions for Future Work

The efficiency of SAHs can be improved by the use of porous material in Single path SAH and Counter path SAH. However there are some considerations that should be addressed for the successful design and integration of

the collector into the practical life.

- Dust and debris removal for a roof top installation
- Solar powered variable speed fan is preferred to be used.
- Operate system by its actual application i.e., if it is for house heating re-circulating warm indoor air through the collector to simulate re- circulation and reheating of indoor air through the collector
- Test system with different glazing materials and not a normal window glass only
- More accurate mass flow rate measuring device can be used.

## REFERENCES

- [1] Akpinar, E.K., Sarsilmaz, C., Yıldız, C., 2004. Mathematical modeling of a thin layer drying of apricots in a solar energized rotary dryer. *International Journal of Energy Research* 28, 739-52.
- [2] Akpinar, E.,K., Kocyigit,F. 2010. Experimental investigation of thermal performance of solar air heater having different obstacles on absorber plates. *International Cominications in Heat and Mass Transfer* 37, 416-421
- [3] Aboul-Enein S., El-Sebaii A.A., Ramadan M.R.I., El-Gohary H.G. 2000. Parametric study of a solar air heater with and without thermal storage for solar drying applications. *Renewable Energy* 21, 505-522
- [4] Aldabbagh, L.B.Y., Egelioglu, F., lkan, M., 2010. Single and double pass solar air heaters with wire mesh as packing bed. *Energy* 35, 3783-3787.
- [5] Alok Chaube, Sahoo, P.K.,and Solanki S.C. 2006. Analysis of heat transfer augmentation and flow characteristics due to rib roughness over absorber plate of a solar air heater. *Renewable Energy* 31, 317-331
- [6] Alvarez, A., Cabeza, O., Muniz, M.C., Varela, L.M., 2010. Experimental and numerical investigation of a flat-plate solarcollector. *Energy* 35, 3707-3716
- [7] Yeh, Ho-Ming, and Ho, Chii-Dong, 2009. Effect of external recycle on the performances of flat-plate solar air heaters with internal fins attached. *Renewable Energy* 34,1340-1347.
- [8] Yeh, Ho-Ming, Ho, Chii-Dong, 2009. Solar air heaters with external recycle *Applied Thermal Engineering* 29 1694-1701.
- [9] El-Sebaii, A.A., Aboul-Enein, S., Ramadan, M. R. I., El-Bialy, E., 2007, Year round performance of double pass solar air heater with packed bed. *Energy Convers Manage* 48, 990-1003.
- [10] Esen, H., 2008. Experimental energy and exergy analysis of a double-flow SAH having different obstacles on absorber plates. *Build Environ* 43, 1046-1054.
- [11] Flores-Irigollen A. Ferna´ndez J.L., Rubio-Cerda . b, E. Poujol, F.T., 2004, Heat transfer dynamics in an inflatable-tunnel solar air heater. *Renewable Energy* 29, 1367-1382
- [12] Garg,H.P. and Adhikari R.S., 1999. Performance Evaluation of a single solar air heater with N-Subcollectors Connected in Different combination. *Int. J. Energy Res.*, 23,

403-414

[13]Goswami D.Y., Kreith F., Kreider J.F, 2000. Principles of Solar Engineering 2<sup>nd</sup> edition. Philadelphia, PA. Taylor and francis.

[14]Gupta, M.K., Kaushik, S.C., 2009. Performance evaluation of solar air heater for various artificial roughness geometries based on energy, effective and exergy efficiencies. Renewable Energy 34, 465-476.

[15]Hans, V. S., Saini R.P., Saini, J.S. 2009. Performance of artificially roughened solar air heaters-A review. Renewable and Sustainable Energy Reviews 13,1854-1869

## Appendix

**Table: Thermal resistance**

	1/k,m.K/W	R,m <sup>2</sup> . K/W
Face brick	0.76	
Common brick	1.39	
Stone	0.55	
Concrete block, sand and gravel aggregate, 200 mm		0.18
Lightweight aggregate, 200mm		0.38
“          “          150mm		0.29
Stucco	1.39	
Siding , asbestos-cement, 6mm, lapped		0.04
Asphalt insulating, 13mm		0.14
Wood plywood, 10mm		0.10
Aluminum or steel, backed with		0.32
Insulating board, 10 mm		
<b>Sheathing</b>		
Asbestos-cement	1.73	
Plywood	8.66	
Fiberboard,          regular          density,	13	mm
0.23		
Hardboard, medium density	9.49	
Particle board, medium density	7.35	
<b>Roofing</b>		
Ashphalt shingles		0.08
Built-up roofing, 10mm		0.06
<i>concrete</i>		
Sand and gravel aggregate	0.55	
Lightweight aggregate	1.94	

<b>Insulating material</b>		
Blanket and batt, mineral fiber, 75-90 mm		1.94
135-165 mm		3.35
Board and slab, glass fiber, organic bond	27.7	
Expanded polystyrene, extruded	27.7	
Cellular polyurethane	43.8	
Loose fill, mineral fiber, 160 mm		3.35
Cellulosic	21.7 – 25.6	
Gypsum or plaster board, 15 mm		
16 mm		0.08
Plaster materials, cement plaster	1.39	
Gypsum plaster, lightweight, 16 mm		0.10
Wood, soft (fir, pine, etc.)	8.66	
Hardwood (maple, oak, etc)	6.31	
		0.066

<b>Air resistance</b>		
Surface, still air (surface emissivity of 0.11)		
0.9) horizontal, heat flow up		
Horizontal heat flow down		
0.16		
Vertical, heat flow horizontal		
0.12		
Surface, moving air, heating season, 6.7m/s		
0.029		cooling season, 3.4 m/s
0.044` `Air space, surface emissivity of 0.8, horizontal		
0.14		
Vertical		
0.17		
Surface emissivity of 0.2, horizontal		
0.24		
Vertical		
0.36		

	<b>Summer</b>	<b>Winter</b>
Single glass	5.9	6.2
Double glass, 6-mm air space	3.5	3.3
<b>13-mm air space</b>		
<b>Triple glass, 6-mm air spaces</b>	<b>3.2</b>	<b>2.8</b>
<b>13-mm air spaces</b>		
<b>Storm windows, 25 to 100-mm air space</b>	<b>2.5</b>	<b>2.2</b>
	<b>2.2</b>	<b>1.8</b>



---

---

2.8

2.3

---

### Outdoor requirements for ventilation

---

requirements	Function	Estimated occupancy per 100 m <sup>2</sup> floor area	Outdoor-air	
			Per person, L/s	
			Nonsmoking	Smoking
	Offices	7	10	
2.5	Meeting and waiting spaces	60	17.5	
3.5	Lobbies	30	7.5	
2.5				

### Infiltration constants for infiltration

---

Quality of construction	a	b
c		
Tight	0.15	0.010
0.007		
Average	0.20	0.015
0.014		
Loose	0.25	0.020
0.022		

### Shading coefficients

---

Coefficient	Shading
-------------	---------

---

shades Type of glass	Thickness , mm	No indoor shading	Venetian blinds		Roller
			Medium	Light	Dark
Light					
Single glass 0.25	3	1.00	0.64	0.55	0.59
Regular sheet 0.25	6-12	0.95	0.64	0.55	0.59
Plate 0.30	6	0.70	0.57	0.53	0.40
Heat-absorbing 0.28	10	0.50	0.54	0.52	0.40
Double glass					
Regular sheet 0.25	3	0.90	0.57	0.51	0.60
Plate	6	0.83	0.57		
Reflective	6	0.2-0.4	0.2-0.33		

#### Viscosity and density of dry air at standard atmospheric pressure

Temperature, °C	Viscosity $\mu$ , $\mu\text{Pa} \cdot \text{s}$	Density $\rho$ , $\text{kg}/\text{m}^3$
-10	16.768	1.3414
0	17.238	1.2922
10	17.708	1.2467
20	18.178	1.2041
30	18.648	1.1644
40	19.118	1.1272
50	19.588	1.0924

**Contraction coefficients in sudden contractions**

$A_2/A_1$	$C_c$	$\left(\frac{1}{C_c} - 1\right)^2$
0.1	0.624	0.366
0.2	0.632	0.340
0.3	0.643	0.310
0.4	0.659	0.270
0.5	0.681	0.221
0.6	0.712	0.160
0.7	0.755	0.103
0.8	0.813	0.050
0.9	0.892	0.010
1.0	1.000	0.000

**Geometry factor in equation for pressure loss in circular 90° elbows**

$$p_{\text{loss}} = \frac{V^2 \rho}{2} (\text{geometry factor}) \quad \text{Pa}$$

$$\text{Ratio} = \frac{\text{radius of curvature}}{\text{diameter}}$$

Geometry factor

Mitered	1.30
0.6	0.90
0.73	0.45
1.0	0.33
1.5	0.24
2.0	0.19

**Typical values of U**

Type of glazing	$U, \text{W/m}^2 \cdot \text{K}$
Unglazed	13-15
Single	6-7
Double	

